

# Strapping Requirements for Water Heaters

The State of California requires that all water heaters in our area are to be supported and strapped to prevent movement during an earthquake.

A metal strap, not less than 22 gauge, nor less than 3/4" wide will be used. The means of connection to the

structure shall be made by the use of a screw not less and 1/4" in size with a minimum penetration of 1 1/2" into a wood stud of the wall. A cut washer shall be used between the head of the screw and the strap to insure a positive support.

## Sample #1

Drill Pilots on centerline of stud, insert screws through punched holes in strap.

These types of supports are over-the-counter products sold as a packaged units.

This strap is installed 6" above the control unit.

This 18" stand is required for heaters installed in a garage location.

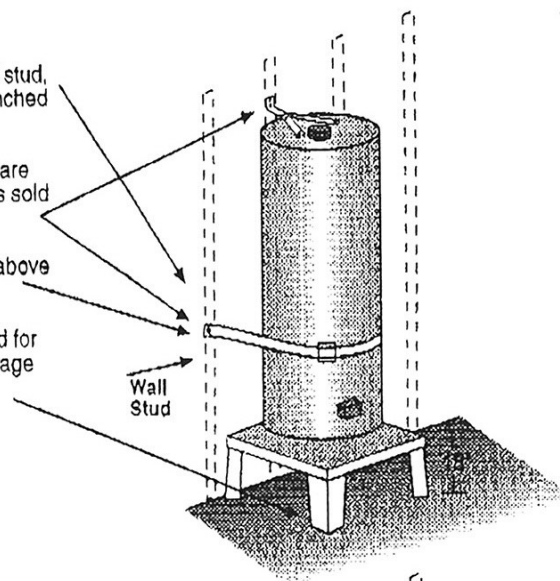

## Sample #2

Drill pilots on centerline of stud, insert screws through punched holes in strap.

Minimum 22 Gauge metal strap material installed within the top 1/3 of the heater and the bottom 1/3 of the heater.

Minimum 1/4" screws with minimum 1 1/2" penetration are allowed.

This 18" stand is required for heaters installed in a garage location.

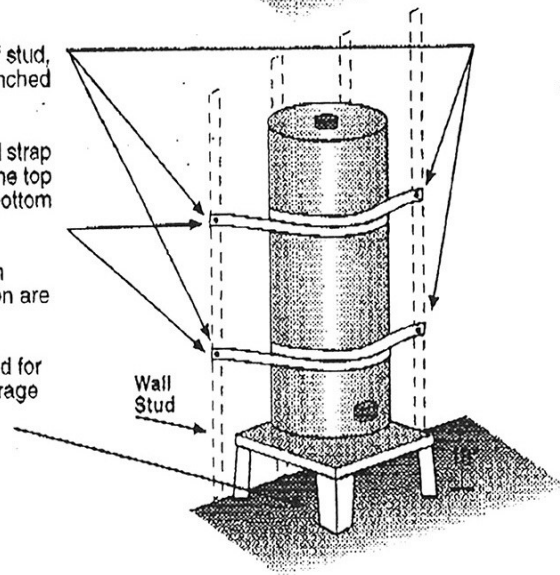

**ALTERNATE METHODS TO BE APPROVED BY THE CITY OF VISTA**

**Contact the Building Division at 760-639-6105**