

CITY OF VISTA STANDARD DRAWINGS



UPDATED MAY 2023

**THIS SHEET INTENTIONALLY
LEFT BLANK**

TABLE OF CONTENTS

MODIFICATIONS

Modifications to San Diego Regional Standard Drawings

DRAINAGE STRUCTURES

DRN-01 Corrugated metal pipe drop inlet

DNR-02 Storm Drain Trench Backfill Requirements

ELECTRICAL SYSTEMS

ELE-01A LED Street Light Type and Location

ELE-01B LED Street Light Installation Criteria

ELE-01C LED Street Light Installation Criteria

ELE-02A LED Street Lighting Standards

ELE-02B LED Street Lighting Standards

ELE-02C LED Street Lighting Standards

ELE-02D LED Street Lighting Standards

ELE-02E LED Street Lighting Standards

ELE-02F LED Street Lighting Standards

ELE-02G LED Street Lighting Standards

SEWERAGE SYSTEMS

SWR-01 Standard Sewer Legend and Symbols

SWR-02 Sewer, Water, & Storm Mainline Separation

SWR-03 Standard Sewer Precast Concrete Manhole (4' Ø)

SWR-04 Standard Sewer Precast Concrete Manhole (5' Ø)

SWR-5A Standard Sewer Precast Concrete Drop Manhole

SWR-05B Standard Sewer Precast Concrete Drop Manhole Notes

SWR-06 Standard 24"Ø. Sewer Manhole Frame and Cover

SWR-07 36" Ø Manhole Frame and Two Concentric Covers (Heavy Duty)

SWR-08 Standard Sewer Dead End Cleanout

SWR-09 Standard 12" Ø Sewer Cleanout Frame and Lid

SWR-10 Sewer Force Main Cleanout

SWR-11 Standard Sewer Pipe Zone and Trench Backfill

SWR-12 Standard Pipe Trench Detail in Existing Streets

SWR-13 Concrete Crown Protection for Existing Sewer Inlets

SWR-14 Concrete Support for Undercut Sewer Pipe

SWR-15 Concrete Encasement

SWR-16 Standard Sewer Cut-off Wall Anchor

SWR-17 Sewer Lateral House Connection

SWR-18 Sewer Lateral House Connection (Deep Cut)

TABLE OF CONTENTS

SWR-19	Intentionally Left Blank	SURFACE IMPROVEMENTS
SWR-20	Sewer Cut-In Wye Connection	SRF-01A Public Street Name Sign Details (For Non-Signalized Intersection)
SWR-21A	Sewer Easement Gate	SRF -01B Public Street Name Sign Details (For Non-Signalized Intersection)
SWR-21B	Sewer Easement Gate	SRF -01C Private Street Name Sign Detail (For Non-Signalized Intersection)
SWR-21C	Easement Gate Barrel Lock Assembly	SRF -02 Intentionally Left Blank
SWR-21D	Easement Gate Barrel Lock Assembly	SRF -03A Public and Private Street Design Criteria (Sheet 1 of 4)
SWR-22	Sewer Access Road Turn Around Types	SRF -03B Public and Private Street Design Criteria (Sheet 2 of 4)
SWR-23	Sewer Access Road Structural Sections	SRF -03C Public and Private Street Design Criteria (Sheet 3 of 4)
SWR-24	Sewer Lateral Tables	SRF -03D Public and Private Street Design Criteria (Sheet 4 of 4)
SWR-25	Standard Residential Sewer Lateral and Cleanout	SRF -04 Mailbox Installation in Sidewalk
SWR-26	Typical Gravity Grease Interceptor	SRF -05A Alley Type Driveway
SWR-27	Shallow Sewer Manhole	SRF -05B Alley Type Driveway
SWR-28	Manhole Frame and Cover (Locking Device)	SRF -06A 6 Lane Prime Arterial (Divided) Typical Section
SWR-29	Cast Iron Ring Covers	SRF -06B 6 Lane Urban Arterial (Divided) Typical Section
SWR-30A	Concrete Manhole Collar (Type A)	SRF -06C 4 Lane Major Arterial (Divided) Typical Section
SWR-30B	Concrete Manhole Collar (Type B)	SRF -06D 4 Lane Collector (undivided) Typical Section
SWR-30C	Concrete Manhole Collar (Type C)	SRF -06E 2 Lane Collector (with Two_way Left Turn Lane) Typical Section
SWR-31	Existing Sewer Manhole Abandonment	
SWR-32	Outfall & Trunkline Sewer Connections	
SWR-33	Sewer Manhole Reconstruction	
SWR-34	Concrete Apron for Sewer Manhole (Untraveled Areas)	

TABLE OF CONTENTS

SRF -06F	2 Lane Collector Street Typical Section	TRAFFIC AND STRIPING
SRF -06G	2 Lane Lite Collector/Local Street Typical Section	TRF-01 Intentionally Left Blank
SRF -06H	Cul-De-Sac Street Typical Section	TRF-02 Speed Bumps
SRF -06I	Hillside Street Typ. Section (being updated)	TRF-03A Street Name Sign Details for Signalized Intersections
SRF -06J	Alley Typical Section	TRF-03B Street Name Sign Details for Signalized Intersections
SRF -06K	Semi-Rural Rd. Typ. Section (being updated)	TRF-03C Street Name Sign Details for Signalized Intersections
SRF -07	Gutter Transition for Type 'B' Curb Inlets	TRF-03D Street Name Sign Details for Signalized Intersections
SRF -08A	Trench Resurfacing	TRF-03E Street Name Sign Details for Signalized Intersections
SRF -08B	Trench Resurfacing Notes	TRF-04 Entering & Leaving City Sign Details
SRF -09	Intentionally Left Blank	TRF-05 Standard Loop Detector Layout
SRF -10A	Modified Rolled Curb Transition Detail	TRF-06 Sign Post Footing in Hardscape
SRF -10B	Modified Rolled Curb Transition Detail	
SRF -11A	Temporary Steel Plate Covers	
SRF -11B	Temporary Steel Plate Covers (Notes)	
SRF -12	Cold Milling Details	
SRF -13	Pavement Restoration Details	
SRF -14	Monitoring Well Abandonment	
SRF -15	Intentionally Left Blank	
SRF -16	Concrete Retaining Wall and Sidewalk	

**THIS SHEET INTENTIONALLY
LEFT BLANK**

MODIFICATIONS

**THIS SHEET INTENTIONALLY
LEFT BLANK**

**CITY OF VISTA MODIFICATIONS TO THE
SAN DIEGO REGIONAL STANDARD DRAWINGS**

DWG.	MODIFICATION
D-27	Add: A maximum of three (3) combined outlets in lieu of standard D-25
D-40	Add: "T" dimension shall be a minimum of three (3) times the nominal rip-rap diameter
D-75	Add: 6"x6"x#10x#10 welded wire mesh, instead of stucco netting
G-4	Replace type 'A' with SRF-10A
G-6	Replace type 'B-3' with SRF-15
G-11	Remove curb/gutter and sidewalk from score-mark to score-mark or from joint-to-joint, or approved combination
G-14	Change thickness in driveways for Commercial/Industrial/Multi-Family from 5-1/2" to 6"
G-24	Replace with SRF -8A and 8B
G-25	Replace with SRF -8A and 8B
G-27	Change slope of ramp from 8.33% maximum to 7.1% maximum. Change note 4 to read: "Landing cross slope shall be 1.5% maximum in both directions".
G-28	Change slope of ramp from 8.33% maximum to 7.1% maximum. Change note 4 to read: "Landing cross slope shall be 1.5% maximum in both directions".
G-29	Change slope of ramp from 8.33% maximum to 7.1% maximum. Change note 3 to read: "Landing cross slope shall be 1.5% maximum in both directions".
G-31	Change slope of ramp from 8.33% maximum to 7.1% maximum. Change note 2 to read: "Landing cross slope shall be 1.5% maximum in both directions".
G-32	Change slope of ramp from 8.33% maximum to 7.1% maximum. Change note 6 to read: "Landing cross slope shall be 1.5% maximum in both directions".
G-33	Replace with SFR-8A and 8B
G-36	Replace with SFR-8A and 8B
M-4	Add: To be used only with specific approval of the City Engineer
SM-03	Replace with SWR-32
SM-08	Replace with SWR-31
SP-02	Replace with SWR-11

**THIS SHEET INTENTIONALLY
LEFT BLANK**

DRAINAGE STRUCTURES

**THIS SHEET INTENTIONALLY
LEFT BLANK**

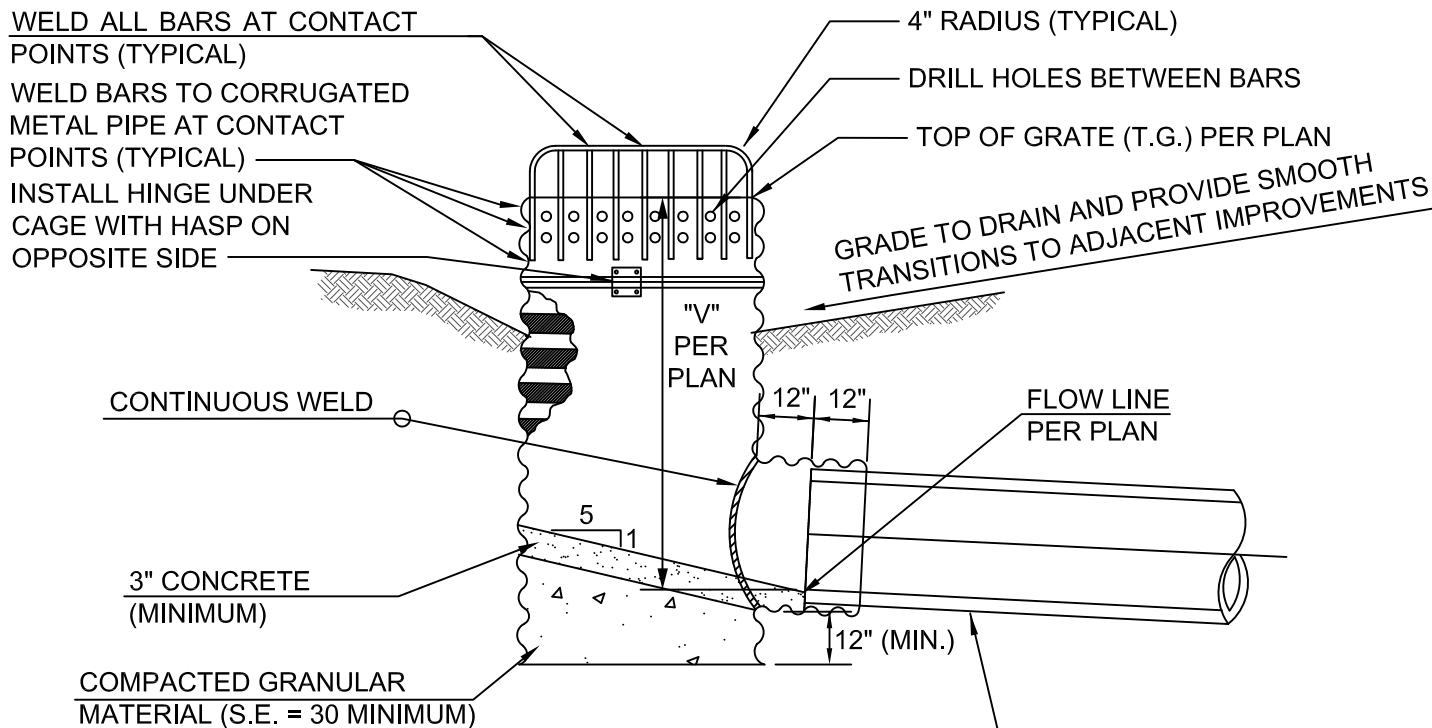

PROFILE

1/2" Ø X 1-1/2" LONG HASP

CORRUGATED METAL PIPE INLET (4' DIA., 16 GAUGE)

HINGE

PLAN

#5 GALVANIZED REINFORCING STEEL BARS GRADE 60, AT 6" O.C. (TYPICAL)

GROUT ANNULAR SPACE FROM TOP THROUGH HOLES IN CORRUGATED METAL PIPE

REINFORCED CONCRETE STORM DRAIN PIPE PER PLAN

CORRUGATED METAL PIPE OUTLET PER DROP INLET TABLE BELOW

DROP INLET TABLE	
REINFORCED CONCRETE PIPE SIZE	CORRUGATED METAL PIPE OUTLET SIZE
18"	24"
24"	30"
30"	36"

NOTES:

1. ALL COMPONENTS SHALL BE GALVANIZED.
2. INSTALL #5 GALVANIZED REINFORCING STEEL BARS INSIDE CORRUGATED METAL PIPE ABOVE AND BELOW JOINT TO SUPPORT UPPER SECTION AND ALLOW HINGE AND HASP TO SECURE TOP SECTION.
3. SEE SDRSD D-16 FOR ADDITIONAL NOTES.

LEGEND



Revision	By	Apprvd	Date
New		WH	01/18/90
Updated	TR	GM	10/22/12

CITY OF VISTA
STANDARD DRAWING

CORRUGATED METAL PIPE DROP INLET

[Signature]
CITY ENGINEER, DATE
RCE 55075

DRAWING NUMBER: **DRN-01**

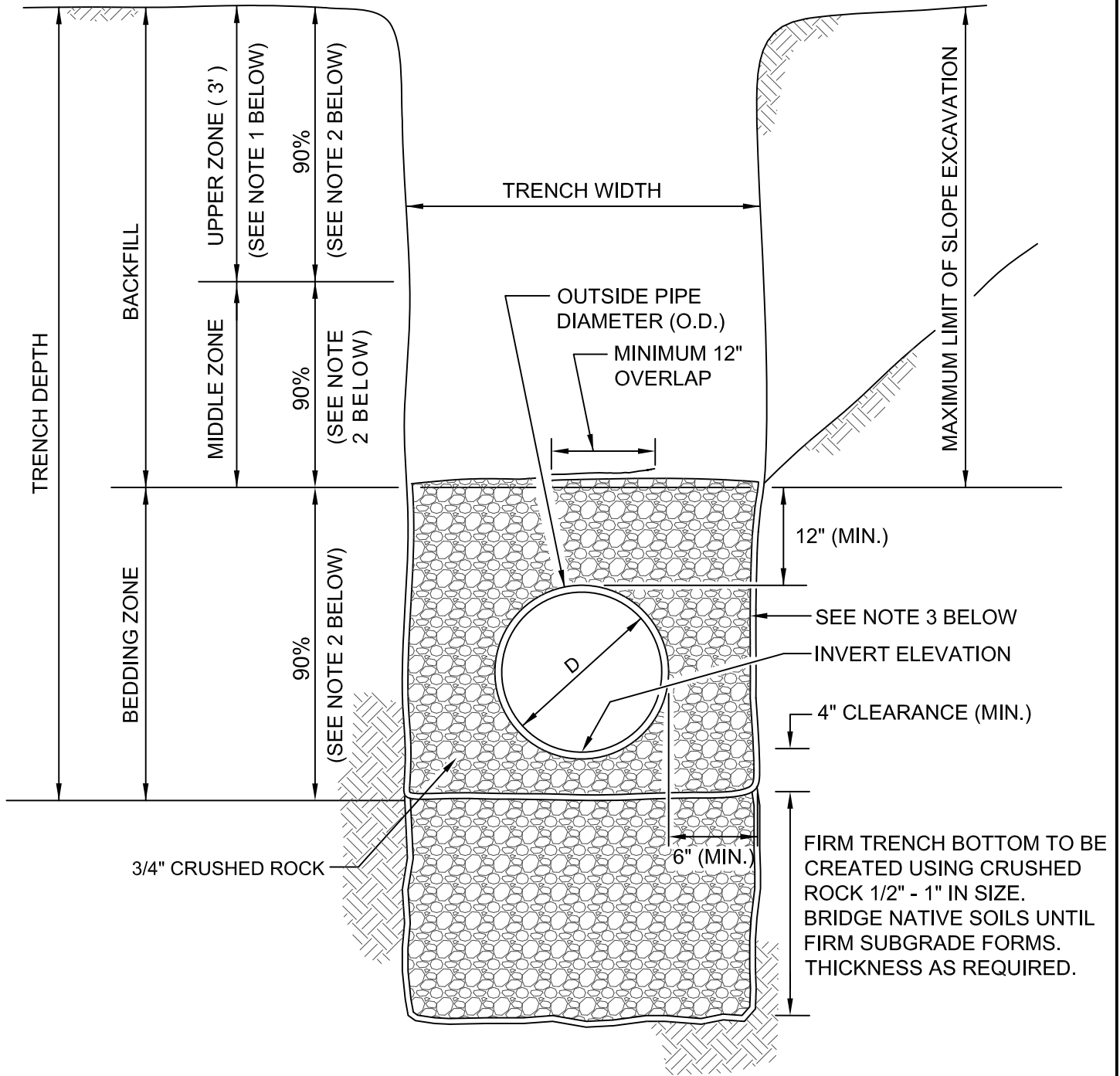

SECTION

NOTES:

- SEE CITY OF VISTA STANDARD DRAWING SRF-08A AND SRF-08B (TRENCH PAVING STANDARD) WHEN TRENCHING ON IMPROVED STREETS - NOTE 95% COMPACTION IS REQUIRED ONE FOOT BELOW THE REQUIRED STREET STRUCTURAL SECTION.
- INDICATES THE MINIMUM RELATIVE COMPACTION.
- 90N NON-WOVEN NEEDLE PUNCHED GEOTEXTILE PER 2012 GREENBOOK SECTION 213-2 SHALL ENVELOPE THE 3/4" CRUSHED ROCK IN THE BEDDING ZONE.

Revision	By	Apprvd	Date	CITY OF VISTA STANDARD DRAWING		
New	TR	SS	09/03/08	STORM DRAIN TRENCH BACKFILL REQUIREMENTS		
Updated	TR	GM	10/22/12			DRAWING NUMBER: DRN-02

ELECTRICAL SYSTEMS

**THIS SHEET INTENTIONALLY
LEFT BLANK**

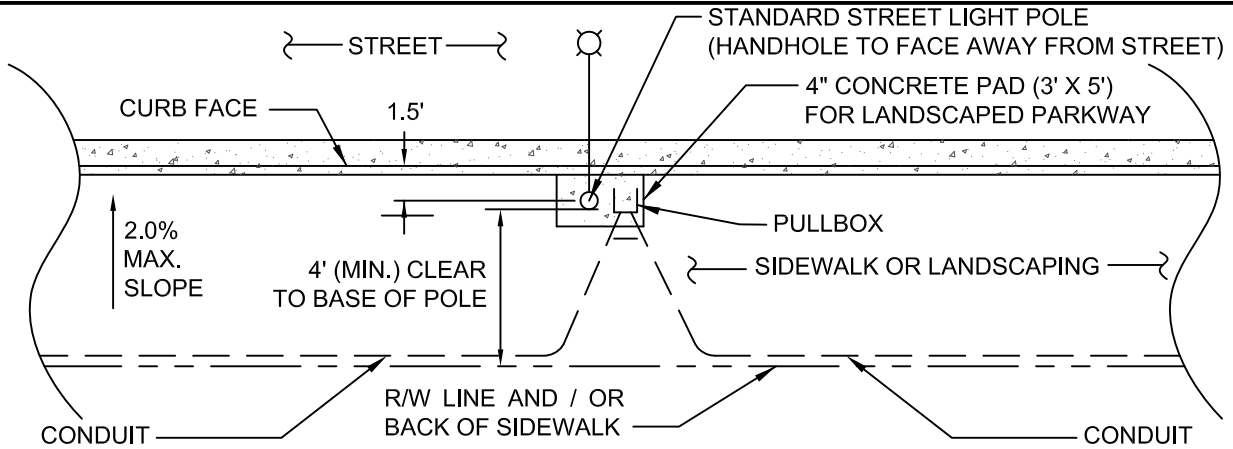

CASE 1: FULL WIDTH SIDEWALK OR NO SIDEWALK

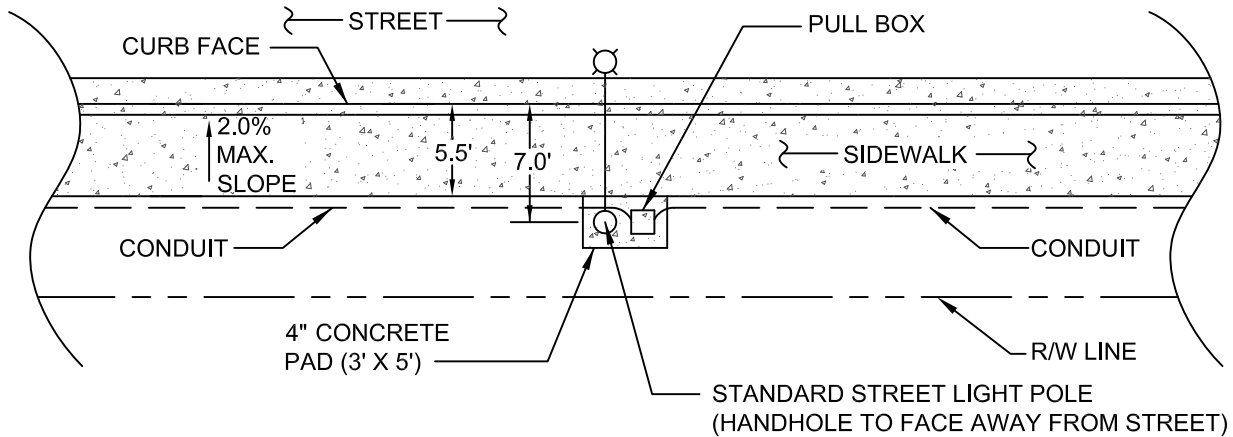

CASE 2: TYPICAL 5' WIDE SIDEWALK

NOTES:

1. STREET LIGHT LOCATION MUST BE STAKED PRIOR TO TRENCHING FOR INSTALLATION OF ELECTRIC, GAS, TELEPHONE AND CABLE TELEVISION CONDUITS TO AVOID CONFLICT.
2. STREET LIGHT BASES SHALL BE INSTALLED PRIOR TO SIDEWALK.
3. CONCRETE GLASS AND FINISH REQUIREMENTS FOR CONCRETE PAD SHALL BE PER SDRSD G-7, G-9 AND G-10.
4. MODIFY IRRIGATION APPURTENANCES AS NECESSARY TO AVOID CONFLICT WITH STREET LIGHT, PULL BOX, CONCRETE PAD AND CONDUIT LOCATION.
5. STREET LIGHTS SHALL BE PLACED AT EVENLY SPACED INTERVALS PER THE TABLE BELOW OR AS APPROVED BY THE CITY ENGINEER.

ST. LT. WATTAGE / MODEL	SPACING CRITERIA
37 WATT BetaLED (STR-LWY-2M-HT-02-D-UL-SV-525-R UTL)	EVERY 150 LF STAGGERED
92 WATT BetaLED (STR-LWY-3M-HT-04-D-UL-SV-700-R UTL)	EVERY 165 LF STAGGERED
116 WATT BetaLED (STR-LWY-5M-HT-05-D-UL-SV-700-R UTL)	FOR TRAFFIC SIGNAL POLES

LEGEND



Revision	By	Apprvd	Date
New	TR	GM	10/17/12

CITY OF VISTA
STANDARD DRAWING

**LED STREET LIGHT
TYPE AND LOCATION**

[Signature]
CITY ENGINEER, DATE
RCE 55075

DRAWING NUMBER: **ELE-01A**

120 VOLT SYSTEM

NOTE: STREET LIGHT WIRE INSULATION MARKINGS SHALL BE PER 2012 GREENBOOK SUBSECTION 209-4.2.1

WIRE SIZE: AWG 10 THWN OR 10 THW 600 V WIRE PER CofV STD. DWG. ELE-02D (SIZE SHALL BE PRINTED OR TAGGED ON WIRE) (PER 2012 GREENBOOK 209-4.2.1)

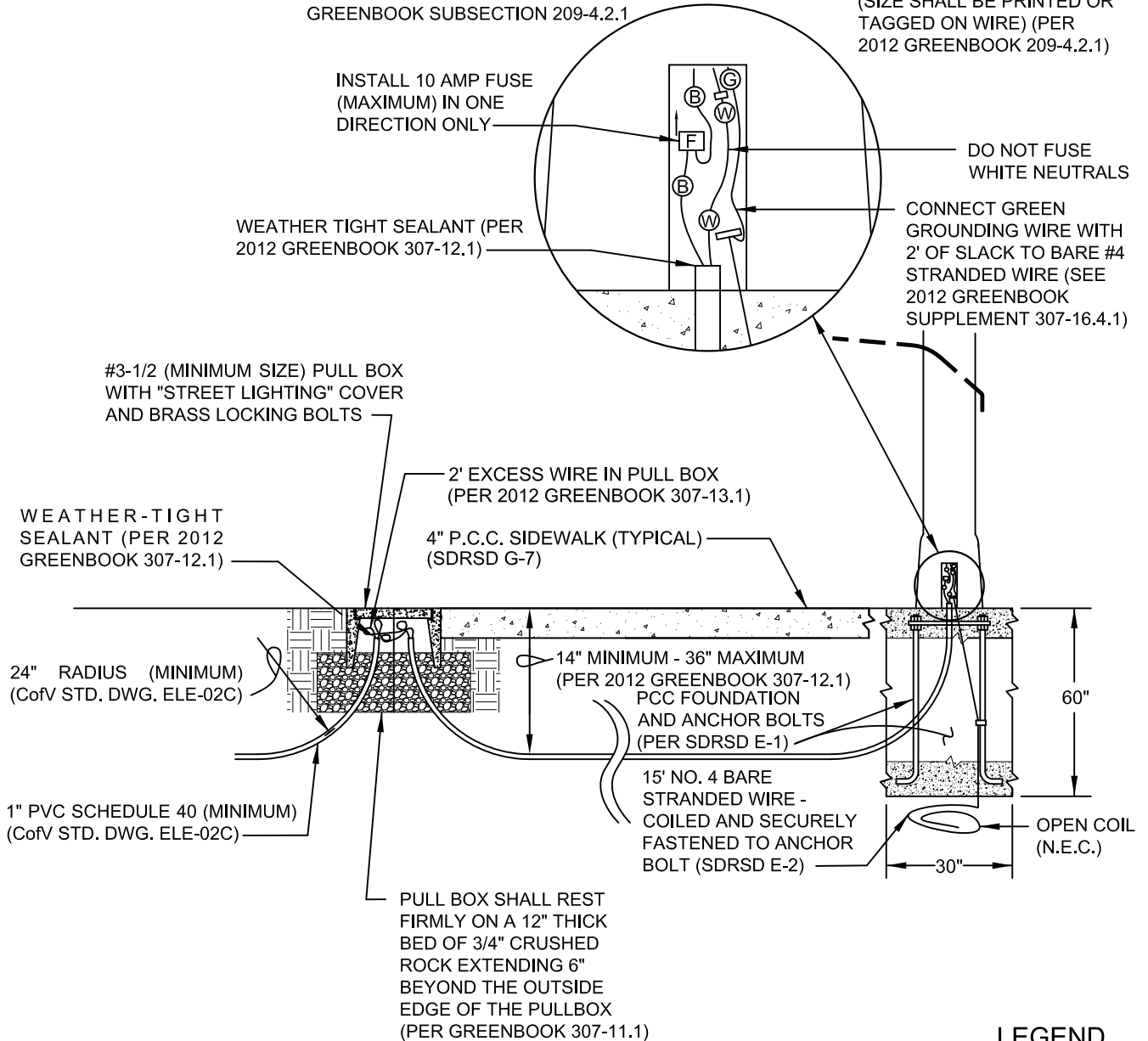

LEGEND

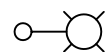

Revision	By	Apprvd	Date
New	TR	GM	10/17/12

CITY OF VISTA
STANDARD DRAWING

LED STREET LIGHT INSTALLATION CRITERIA

CITY ENGINEER, DATE
RCE 55075

DRAWING NUMBER: **ELE-01B**

120 VOLT SYSTEM

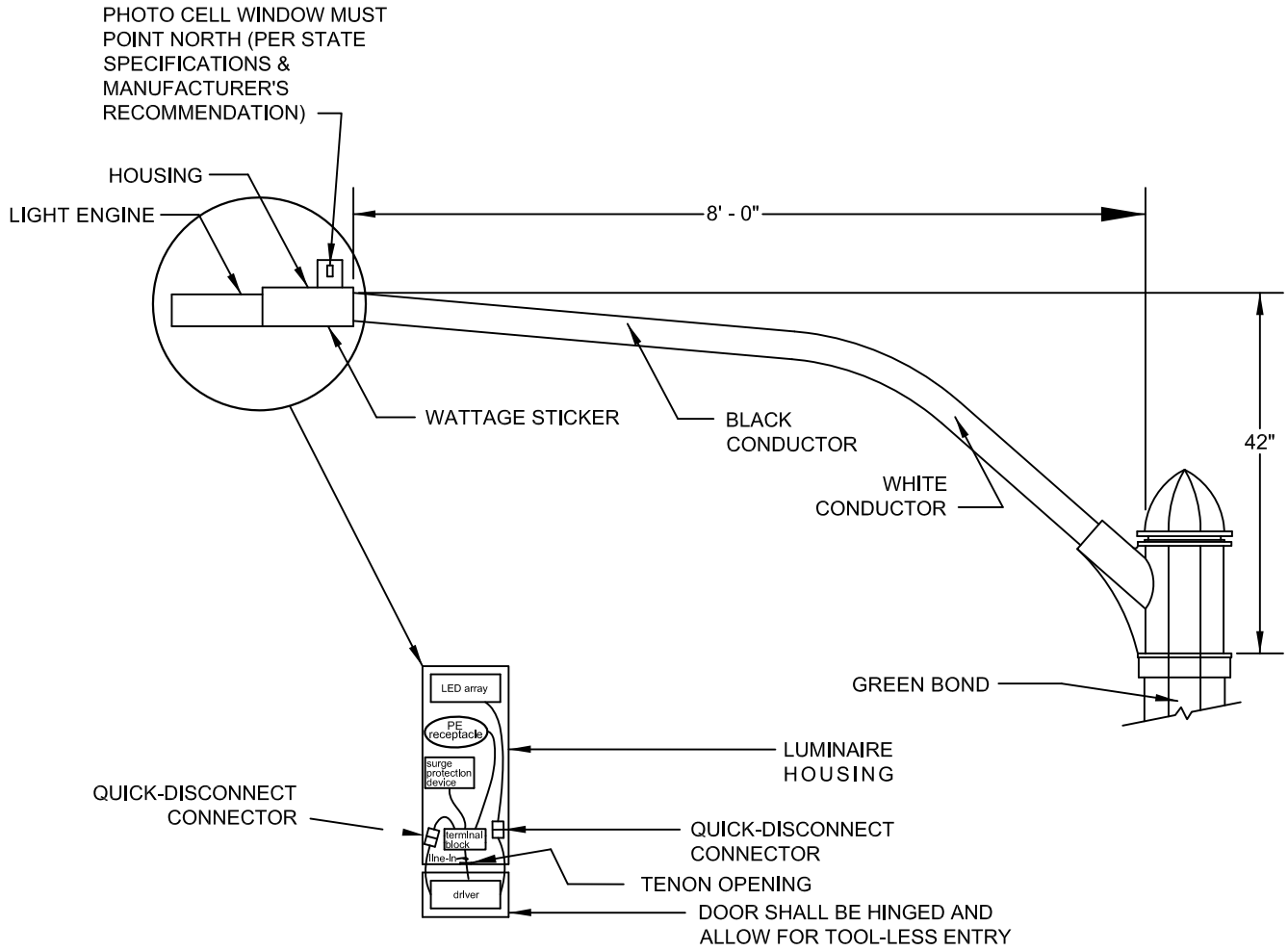

LEGEND

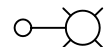

Revision	By	Apprvd	Date
New	TR	GM	10/17/12

CITY OF VISTA
STANDARD DRAWING

Signature

LED STREET LIGHT INSTALLATION CRITERIA

CITY ENGINEER, DATE
RCE 55075

DRAWING
NUMBER: **ELE-01C**

CITY OF VISTA - LED STREET LIGHTING STANDARDS

GENERAL:

New or relocated streetlights located within City R/W or City easements are required to include light emitting diode (LED) luminaires and be constructed per City Standards and per Plan, and field inspected and approved prior to requesting energizing or acceptance.

NON-STANDARD LIGHTING:

Other types and styles of poles and / or non-solid-state (non LED) luminaires may be allowed with PRIOR approval from the City Engineer. Since solid-state LED luminaires have a long life, use less electricity, and are mercury and lead-free, justification must be provided for a non-solid-state luminaire substitution.

INDUSTRY STANDARDS:

LED streetlight luminaires shall meet the applicable requirements of the following industry standards:

1. IES LM-80-08 - Approved Method for Measuring Lumen Maintenance of LED chips (fixture manufacturer must provide extrapolation calculations method of explanation for lumen maintenance derived from in-situ testing upon request)
2. IESNA TM-15-11 (replaces TM-15-07 and TM-15-07 Addendum A) - Luminaire Classification System for Outdoor Luminaires; Backlight, Uplight, and Glare (BUG) Ratings
3. ANSI/NEMA/ANSLG C78.377-2008 - Specifications for the Chromaticity of Solid-State Lighting (SSL) Products
4. IES LM-79-08 - Approved Method: Electrical and Photometric Measurements of Solid-State Lighting Products
5. IEEE C62.41.2-2002 - IEEE Recommended Practice on Characterization of Surges in Low-Voltage (1000 V and less) AC Power Circuits
6. ANSI/UL 1598 - Poles & luminaires; UL
7. ANSI/UL 8750: Additional requirements for LED luminaires as well as drivers and LED arrays

Test data that establishes compliance with the requirements listed above shall be provided upon request.

REFERENCE:

1. Project Plans and Specifications - Location and project-specific details.
2. California Electric Code - As applicable by the Building Department.
3. SDG&E Standards - As applicable.
4. City Standard Drawings.
5. Standard Specifications for Public Works Construction (Greenbook) (latest edition) - Subsections 209 and 307 and all included cross references.
6. San Diego Regional Standard Drawings E-1 & E-2 (as applicable) - for anchor base foundation and ground wire only.
7. Manual of Uniform Traffic Control Devices (MUTCD) (latest edition) - for traffic control and sign installation on poles.

LUMINAIRES:

Fixtures shall be one of the following:

BetaLED / CREE Catalog #: STR-LWY-2M-HT-02-D-UL-SV-525-R UTL (LED SYSTEM WATTS = 37)

BetaLED / CREE Catalog #: STR-LWY-3M-HT-04-D-UL-SV-700-R UTL (LED SYSTEM WATTS = 92)

BetaLED / CREE Catalog #: STR-LWY-5M-HT-05-D-UL-SV-700-R UTL (LED SYSTEM WATTS = 116)

Catalog definitions: STR = product; LWY = family; 2M = Optic: IESNA Type II medium distribution; HT = horizontal tenon mount; 02 = # of LEDs x 10 (20 LEDs); D = LED series; UL = voltage, universal 120-277 Vac; SV = housing color, silver; 525 = 525mA drive current; R = NEMA photocell receptacle; UTL = Factory-Installed Options (UTL = Utility Option) (includes exterior wattage label that reflects watts for the drive current selected. The ability to exceed the selected drive current will be disabled).

3M = Optic: IESNA Type III medium distribution; 04 = # of LEDs x 10 (40 LEDs); 700 = 700mA drive current

5M = Optic: IESNA Type V medium distribution; 05 = # of LEDs x 10 (50 LEDs); 700 = 700mA drive current

General description of LEDway (light emitting diode) Streetlight - Standard fixture utilizes terminal block for power input suitable for #6 - #14 AWG wire and operates at 700mA. Drive current is field switchable. A three-pole terminal block capable of accepting #14 to #10 AWG shall be mounted to the housing inside the electrical compartment. Luminaire shall be provided with capability for optional backlight control. Complete assembly weight shall not exceed 45 lbs. Fixture is designed to mount on a schedule 40, 2" nominal pipe size (NPS) horizontal tenon (minimum 8' in length) and is adjustable +/- 5 degrees to allow for fixture leveling (includes two axis T-level to aid in this process). Fixture, including the LEDs, drivers and electrical components, shall carry a limited five year warranty and housing paint and finish shall carry a ten year warranty.

Color temperature and CRI: 6000K +/- 500 color temperature, minimum 70 CRI

Revision	By	Apprvd	Date	CITY OF VISTA STANDARD DRAWING	
New	TR	GM	10/17/12	LED STREET LIGHTING STANDARDS	CITY ENGINEER, DATE RCE 55075
					DRAWING NUMBER: ELE-02A

CITY OF VISTA - LED STREET LIGHTING STANDARDS

LUMINAIRE HOUSING:

Luminaire housing shall be furnished with an optical assembly, be powder-coated silver, include a level bubble to facilitate installation, allow for tool-less entry and shall include an integral twistlock type receptacle for photoelectric cell control in accordance with the latest EMI-NEMA standards which is adjustable with respect to north and pre-wired to the terminal board.

Luminaire external housing shall have a minimum rating of IP56 as specified in IEC 60529, with the ability to shed water from inside the housing (i.e. weep holes).

The LED luminaire shall be designed for horizontal mounting. The LED assembly shall have a slip-fitted mounting bracket capable of attaching to a two-inch (2") pipe without the need for special mounting parts. They shall be installed in a horizontal position with leveling and clamping to the mast arm pipe accomplished by tightening mounting bolts, which are externally or internally accessible. Bolts shall be minimum 5/8" x 2" size and either stainless steel or cadmium-plated steel.

Luminaire circuitry shall include quick connect / disconnects to allow easy separation and removal of driver and power door. See City of Vista Standard Drawing ELE-1C. Grounding requirements: ANSI/UL Standards and NFPA 70.

The luminaire power unit assembly shall consist of an integral driver, capacitor, 10K surge suppressor, and heavy-duty terminal block. The power unit assembly shall be mounted on a separate component of the luminaire to facilitate replacement.

The luminaire optical chamber shall have a minimum rating of IP66 as specified in IEC 60529.

The luminaire housing cooling system shall consist of a passive heat sink with no fans, pumps, or liquids and shall be designed and constructed to accept a standard plug type, locking, three-pole, three-wire, streetlight photo control. The fixture and finish endurance tested to withstand 5,000 hours of elevated ambient salt fog conditions as defined in ASTM Standard B 117.

All fasteners shall be stainless steel and all polycarbonate components shall be UV stabilized.

An easily-viewable nameplate shall be permanently affixed to the inside of each luminaire housing. The nameplate shall contain the following information: manufacturer's name, manufacturer's catalog number, date of manufacture (month and year), plant location, input power consumption, driver output current, IEC IP Rating, correlated color temperature (CCT), IES light distribution type, IESNA TM-15 BUG ratings, and serial number. A utility-approved luminescent name plate with light source and wattage listed shall also be permanently affixed on the exterior of the luminaire and be visible from the ground.

The driver assembly shall be enclosed in a separate compartment from the optical assembly. The entire fixture shall be 'wet listed' with the optical assembly compartment being rated at IP66. The LED luminaire shall be constructed to provide the required light distribution with the lower edge of the luminaire housing below the entire light source close contact refractors. The luminaire must be Dark Sky compliant with a 'UO' BUG rating. The light distribution pattern shall be per the Fixture Application table in the OPTICAL DISTRIBUTION METHOD & CONFIGURATIONS section below:

OPTICAL DISTRIBUTION METHOD & CONFIGURATIONS:

Optical configurations shall meet the following criteria:

1. No reflectors or single lensed fixture accepted; close contact refractors to be employed for optical distribution
2. Refractors are to be polymeric material rated 5VA, f1 rating
3. Kelvin temperature to be 6,000K (+/- 500)
4. Lumen maintenance at 50,000 hours of life to be no less than 88% of initial lumen output
5. Shall have a 95% survival rate at 50,000 hours
6. Integral 10K surge suppressor for diode and entire system protection

Fixture Application	LED Fixture Wattage	Minimum Lumens @ 100 hrs	Light Distribution Type
Residential Street	37 Watts	2,600 Lumens	IESNA Type II medium distribution
Collector & Arterial Streets	92 Watts	6,490 Lumens	IESNA Type III medium distribution
For above with Traffic Signals	116 Watts	8,900 Lumens	IESNA type V medium distribution

BIRD SPIKES:

Bird spikes are required on luminaire housing and light engine per the catalog numbers listed below:

Component	BETA / CREE Catalog Number
Housing	XA-BRDSPKHSG
Light Engine (37 Watts)	XA-BRDSPK30
Light Engine (92 & 116 Watts)	XA-BRDSOK60

Revision	By	Apprvd	Date	CITY OF VISTA STANDARD DRAWING LED STREET LIGHTING STANDARDS	 CITY ENGINEER, DATE RCE 55075 DRAWING NUMBER: ELE-02B
New	TR	GM	10/17/12		

CITY OF VISTA - LED STREET LIGHTING STANDARDS

DRIVERS:

Light Emitting Diode (LED) drivers shall be component-type consisting of precision wound coils and welded magnetic steel laminations assembled together and impregnated with baked-on, insulating, weatherproof varnish; and metal-cased, hermetically-sealed capacitor, suitable for use on multiple distribution circuits with 60Hz, 120 or 240 Volt rating. The operating sound pressure noise level shall not exceed the ambient noise level by more than five (5) decibels at a distance of 30 feet when measured by a sound level meter conforming to the American Standards for Sound Level Meters. Where the ambient noise level is less, a minimum of 40 decibels shall be assumed.

Power supply / driver shall be field replaceable by means of quick-disconnect connectors and easy access mounting hardware.

Power supply / driver shall be wet-listed in the US and Canada, UL, ROHS compliant, meet Caltrans 611 vibration testing and GR-63-CORE section 4.4.1/5.4.2 earthquake zone 4.

DRIVER SPECIFICATIONS:

Electronic; voltage range = universal 120 - 277 v +/- 10%; frequency = 50/60 Hz; power factor > 90% @ full load; THD < 20% @ full load; output ripple < 10%; output shall be isolated; case temperature rated for -40 to 60C; fully encased and potted; overheat protection, self limited short circuit protection, and overload protected - minimum integral 10k surge protection tested in accordance with IEEE C62.41 and ANSI standard 62.41.2; Driver Life Rating not less than 100,000 hours.

PHOTOELECTRIC CONTROL UNIT:

Fisher-Pierce # FPN7790B (blue cap, 105 - 285 volt range).

The photoelectric unit shall consist of a photoelectric cell in a weatherproof housing which plugs into an EEI-NEMA twist-lock receptacle integral with the luminaire and shall be installed with the clear UV-stabilized photocell window facing north. The control unit shall contain a uniformly coated cadmium-sulfide photoelectric cell suitable for operation with 120 or 240 volt line supply with surge protection to prevent damage and made to fail in the "ON" position. The unit shall have a HID load rating of 1,800 VA with a Tungsten load rating of 1,000 watts.

The response level of the unit to changing light levels shall remain stable throughout the life of the unit (5,000 operations). The "turn-on" level shall be a nominal 1 foot-candle and the "turn-on:turn-off" ratio shall be 1.5.

FUSES:

Fuses shall be slow blow 13/32" x 1 1/2" in-line type in 10 amp size (unless specified otherwise by City Electrician). The fuse shall be installed in the hot leg of the lighting conductor. The circuit shall be fused in the base of the pole - NOT in the pull box. 240-volt installations require each leg to be fused using a double fuse holder and two fuses of appropriate size.

FUSEHOLDERS:

Fuseholders shall be completely waterproof, shall grip the fuse in the load side section when opened, and be able to take a 13/32" x 1 1/2" fuse, with crimp-type tubular terminals of a proper size for the cable in the particular light.

MAST ARMS:

8-foot steel or aluminum.

Mast arms shall be two inch (2") I.P.S. galvanized steel or aluminum and shall be self-supporting without braces, scrolls or rods. Mounting shall be perpendicular to the street centerline unless otherwise directed by the City Engineer. They shall have a minimum of six inches (6") of horizontal straight section at the end of the arm to mount a two inch (2") I.P.S. slipfitter type luminaire mount.

Mast arms shall be eight feet (8') long for all luminaires unless otherwise specified in the plans and shall be capable of handling the EPA and weight of the luminaire. Steel arms shall conform to ASTM A 120. Aluminum arms shall be corrosion resistant alloys such as Aluminum Association wrought alloys 6061 or 6062 or cast alloys 319 or 356.

All exposed hardware shall be stainless steel. All protected hardware not visible after installation shall be cast aluminum and / or stainless steel, hot-dipped galvanized or cadmium-plated steel. Anti-seize shall be used.

Revision	By	Apprvd	Date	CITY OF VISTA STANDARD DRAWING	 CITY ENGINEER, DATE RCE 55075
New	TR	GM	10/17/12	LED STREET LIGHTING STANDARDS	DRAWING NUMBER: ELE-02C

CITY OF VISTA - LED STREET LIGHTING STANDARDS

FOUNDATIONS:

Per SDRSD No. E-1 and E-2. Anchor base foundation only. For E-2 use No. 2 for ground wire; no ground rod.

Anchor bolts shall be the type and size shown on SDRSD E-1 and shall conform to the specifications of ASTM A 307 and be provided with two nuts and two washer each. Bolts, nuts and washers shall be galvanized by the hot-dip process conforming to ASTM A 153 or cadmium-plated with Type NS coating conforming to ASTM A 165. Direct burial poles may use 2-sack mix slurry backfill.

Plumbing of the standard shall be accomplished by adjusting the nuts on the anchor bolts before the foundation cap is placed. Shims or other similar devices for plumbing or raking will not be permitted. After plumbing the standard, anchor bolts shall be cut off 1/4" above the nuts and the exposed surfaces shall be repaired.

CONCRETE POLES:

RESIDENTIAL STREETS: Ameron 2B2-24(37I)2AP6A or 2B2-24(37I)2AP8A (27.5' mounting height)

COLLECTOR AND ARTERIAL STREETS: Ameron 6B1-26(37I)1AP8A (29.83' mounting height)

(Note: Use 8' arm for poles located adjacent to the sidewalk on residential, collector and arterial streets)

Concrete poles shall be tapered, centrifugally cast and prestressed. Poles shall be round black and white marble aggregate or natural exposed aggregate. Pole shape and color shall be uniform for any one project. Replacement poles shall match existing.

The ultimate strength of a pole shall be calculated in accordance with the latest revision of American Concrete Institute (A.C.I.) standard 318. Under working loads (including wind loading, as specified in the latest edition of AASHTO standards), the pole must not be stressed beyond the cracking strength. The pole and mast arm must be capable of handling the EPA and weight of the luminaire.

Aggregates shall conform to current requirements of ASTM C33, except that abrasion requirements therein shall not apply and that no more than seven percent (7%) shall pass a #100 mesh sieve. No dye or sealer shall be used.

The centrifugal casting process shall produce a center duct throughout the length of the pole, which shall be free from sharp projections or edges and shall be a minimum of one and one-half inch (1-1/2") in diameter. All reinforcing steel shall have a minimum cover of five-eighths inch (5/8") of concrete. After curing, the surface of the pole shall be treated to remove cement laitance and to develop the surface texture. When finished, poles shall be without cracks or crazing and shall have a uniform surface (without objectionable mold marks) and texture throughout the entire length. Maximum deviation from stringline at any point shall not exceed 0.03" per foot of length.

Hand hole cover plates shall be aluminum and securing bolts shall be stainless steel tamper-proof bolts of the type installed with a pent-head wrench.

PROTECTIVE COATINGS FOR POLES:

All poles shall be provided with a clear, factory applied Amershield Anti-Graffiti coating.

PULL BOXES:

State No. 3-1/2 Pull Boxes (15 3/8" x 10 1/8"), or approved equal, shall be installed per CALTRANS Standard Plan ES-8 as follows:

1. Located at the end of the conduit run and three feet (3') from SDG&E service point and five feet (5') clear of curb face (NOTE: if the street light is within ten feet (10') of the service point only one pull box is required.
2. Located within five feet (5') of each street light.
3. Located at conduit interval runs of not more than 150 LF. Additional #5 pull boxes will be required for conduit runs over 150 LF long.

The bottom of the pull box shall rest firmly on a twelve-inch (12") thick bed of three-quarter-inch (3/4") crushed rock extending six inches (6") beyond the outside edges of the box. Pull boxes shall be installed behind sidewalk or five feet (5') behind the face of curb or dike and, where practical, shall be installed with the short side parallel to the curb. They shall not be installed in any part of a driveway or other traveled way, unless approved by the City Engineer and provided with a metal traffic cover. Pull box covers shall be inscribed "STREET LIGHTING" and shall be secured with 3/8" bolts, cap screws or studs and nuts made of brass, stainless steel or non-corroding material.

Revision	By	Apprvd	Date	CITY OF VISTA STANDARD DRAWING	 CITY ENGINEER, DATE RCE 55075
New	TR	GM	10/17/12	LED STREET LIGHTING STANDARDS	DRAWING NUMBER: ELE-02D

CITY OF VISTA - LED STREET LIGHTING STANDARDS

CONDUIT AND TRENCH:

All conduit shall be one-inch (1") UL approved heavy wall polyvinyl chloride (PVC) Schedule 40. Conduit shall be encased in a minimum of three inches (3") of sand on all sides. The minimum sweep radius shall be twenty-four inches (24"). The maximum length of a conduit run shall be one hundred fifty feet (150'). The Contractor may, at his expense, use conduit of a larger size, provided the larger size is used for the entire length of the conduit runs between pull boxes (reducing couplings shall not be allowed).

Conduit shall be laid to a depth of not less than thirty inches (30") unless placed under sidewalk in which case only fourteen inches (14") shall be required. Conduit laid in open trench shall not be covered nor shall any trench or inspection hole be backfilled until accepted by the City Engineer of his designated representative. Conduit shall be installed per SDRSD M-15 if in joint trench.

SPLICING:

Splices shall be permitted in pull boxes and lighting standard bases ONLY. All splices shall be waterproofed with epoxy encapsulation or heat shrink tubing.

CONDUCTORS AND SERVICE RUNS:

All conductors shall be stranded copper, THHN, #10AWG minimum. Neither aluminum nor direct-burial cable shall be accepted. All street light systems shall be provided with 110-120V service.

Wire shall conform to the applicable portion of ASTM B3 and B8. Wire size shall be indicated on the "As-Built" plans. Wire connectors shall be approved by the City Engineer or his designated representative and shall bear the UL seal of approval. The installation procedure, connector size and crimping tools shall conform to the manufacturer's recommendations.

Wire from the base of the pole to the luminaire shall be #10. For 120-volt installations, the wires shall be black and white, with black being the hot wire and fused. For 240-volt installations, one hot wire shall be black and the other shall be red. Both hot wires shall be fused. Any ground wires shall be green and connected to a clamp attached to an anchor bolt - NO EXCEPTIONS!

Service runs parallel to the street shall be installed under the sidewalk where new sidewalk is being constructed or directly behind the existing sidewalk. Voltage drop shall not exceed five percent (5%).

PRE-INSTALLATION:

1. Obtain a City R/W permit for any work to be done within a City R/W or City easement. Attached to the R/W permit are the construction requirements applicable to all work performed within the City R/W.
2. Call Underground Service Alert at 800-422-4133 at least 48 hours before excavating.

INSTALLATION AND INSPECTION:

1. Concrete and/or asphalt removal & replacement shall be per City of Vista public street requirements as directed by the City. A sidewalk extension may be required to meet ADA access requirements.
2. Conduit depth shall be as described in the CONDUIT AND TRENCH section. All trenches shall be compacted per the City of Vista public street requirements as directed by the City.
3. Street Lights shall be located per City approved plan or per City of Vista Standard Drawing ELE- 1A-1C, and shall not be relocated without prior City approval.
4. Minimum Engineering Department Inspections Required:
 - a. Schedule an Engineering Department Inspection 48 hours in advance by calling 760-639-6113
 - b. All work performed within a Public Right-Of-Way
 - c. All conduit placement
 - d. Prior to and during any concrete foundation placement
 - e. Pole installation
5. Building Department inspection is required for final wiring and splicing prior to energizing. Contact the Building Department for inspection 48 hours in advance at 760-639-6106.
6. Pedestrian and vehicle traffic control and access shall be maintained per the Plans, Specifications, 2012 Standard Specifications for Public Works Construction (Greenbook) subsection 7-10 (Public Convenience and Safety), MUTCD, and as otherwise required or directed by the City.

Revision	By	Apprvd	Date	CITY OF VISTA STANDARD DRAWING	 CITY ENGINEER, DATE RCE 55075
New	TR	GM	10/17/12	LED STREET LIGHTING STANDARDS	DRAWING NUMBER: ELE-02E

CITY OF VISTA - LED STREET LIGHTING STANDARDS

ACCEPTANCE AND ENERGIZING:

1. Upon completion of all street light construction, the Contractor (on public projects) or Developer (on private development projects) shall submit two (2) sets of professionally drafted streetlight "As-Built" plans on 11" x 17" size mylar sheets to the Development Services Division (Permit Center), City of Vista, showing the following information:
 - a. Layout of curbs, gutter, sidewalks, driveways and other improvements, drawn to scale
 - b. Location of street lights, with dimensions from the nearest cross street intersection and between streetlights
 - c. Location of pull boxes dimensioned from the streetlights, curbs or other features
 - d. Location of service point (power source) and SDG&E identification number
 - e. Location of conduit service runs dimensioned from face of curb, edge of pavement or back of sidewalk as applicable
 - f. Size and type of wire used
 - g. Size (wattage and voltage rating) and type (LED) of each lamp and number of lamps used
 - h. North arrow
 - i. Contractor's name, address and telephone number
 - j. Identifying project name and number

- INCOMPLETE SUBMITTALS WILL NOT BE ACCEPTED -

2. For private development projects, the Developer shall submit a one-year Streetlight Energy fee for each new streetlight, paid when streetlight "As-Built" plans are submitted. The fees shall be paid in accordance with the most recent City of Vista Fee Schedule. All installations shall be guaranteed for a period of one year from the date of acceptance by the City for maintenance.
3. After "As-built" plans have been accepted by the City, the Contractor or Developer shall anticipate a minimum of five (5) working days for the City to contact SDG&E for streetlight energizing. Release of a Building Occupancy requires that streetlights be energized.

Revision	By	Apprvd	Date	CITY OF VISTA STANDARD DRAWING	
New	TR	GM	10/17/12	LED STREET LIGHTING STANDARDS	CITY ENGINEER, DATE RCE 55075
					DRAWING NUMBER: ELE-02F

CITY OF VISTA - LED STREET LIGHTING STANDARDS

SAMPLE STREETLIGHT "AS-BUILT" PLAN

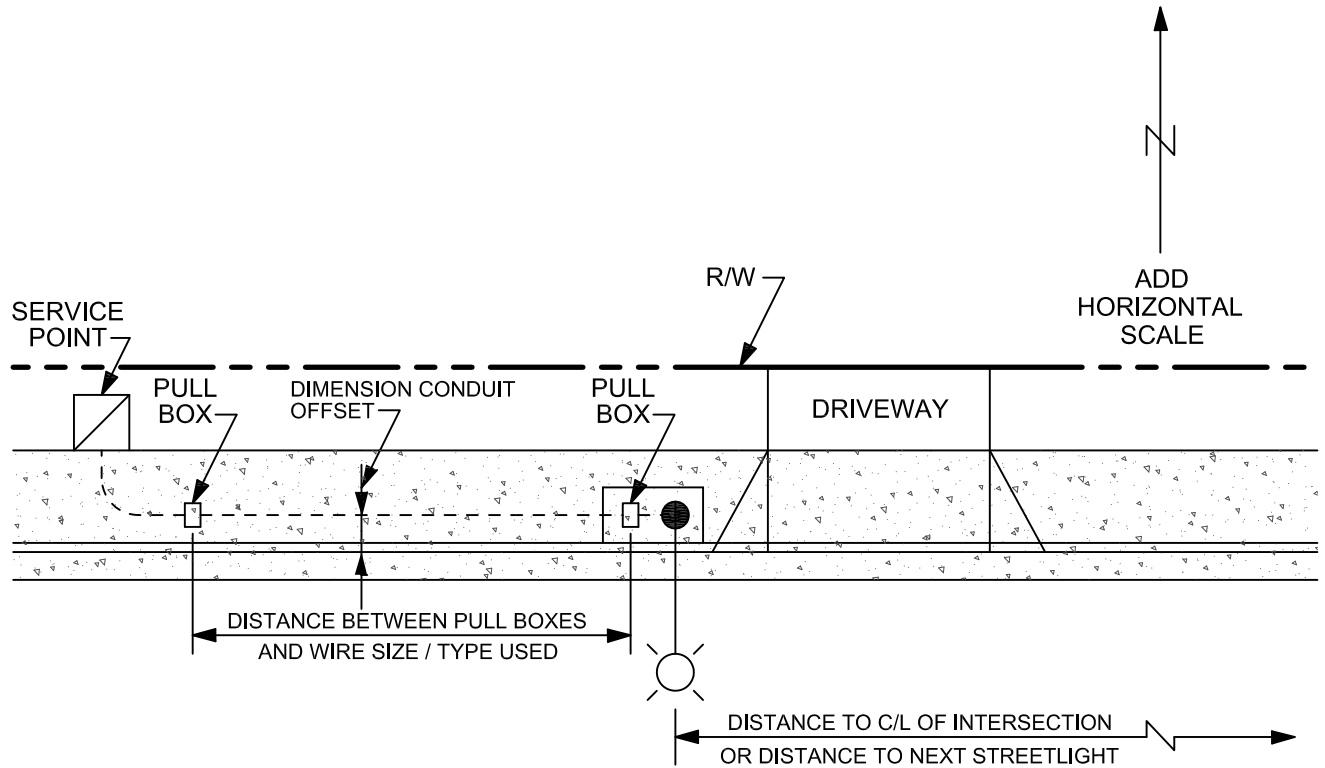

STREET NAME

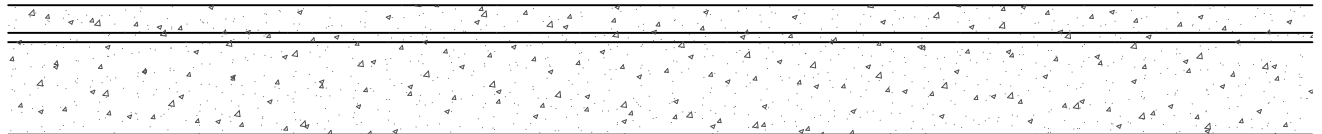

STREETLIGHT "A-BUILT" PLAN FOR [LOCATION / PROJECT NO.]

INCLUDE THE FOLLOWING ON THE PLAN: STREETLIGHT LINE VOLTAGE, FIXTURE WATTAGE, FIXTURE MANUFACTURER, POLE MANUFACTURER, POLE TYPE AND MODEL NUMBER, CONTRACTOR'S NAME, ADDRESS AND TELEPHONE NUMBER (INCLUDING AREA CODE).

Revision	By	Apprvd	Date	CITY OF VISTA STANDARD DRAWING	
New	TR	GM	10/17/12	LED STREET LIGHTING STANDARDS	CITY ENGINEER, DATE RCE 55075
					DRAWING NUMBER: ELE-02G

SEWERAGE SYSTEMS

**THIS SHEET INTENTIONALLY
LEFT BLANK**

DESCRIPTION	SYMBOL	CITY OF VISTA STD. DWG. NO.	QUANTITY
SEWER MAIN		SWR-11 & -12	LF
SEWER MANHOLE		SWR-03, -04 & -05	EA
CLEAN-OUT		SWR-08	EA
DEAD END MANHOLE		SWR-08	EA
STUB			EA
CONCRETE ENCASEMENT		SWR-15	LF
CUT OFF WALL		SWR-16	EA
SEWER LATERAL		SWR-17, -18 & -25	EA
FORCE MAIN			LF
CUTTING & PLUGGING ABANDOND SEWER MAIN			
PIPE CASING			
PIPE SUPPORT FOR UNDERCUT OF EXISTING MAINS			
PROPERTY LINE			
EDGE OF PAVEMENT			
EXISTING SEWER LATERAL			
EXISTING WATER LATERAL			
EXISTING GAS LINE ("HP" INDICATES HIGH PRESSURE)			
EXISTING ELECTRIC CONDUIT /CABLE ("OH" INDICATES OVERHEAD)			
EXISTING TELEPHONE CONDUIT(S)			
EXISTING TELEVISION CONDUIT(S)			
EXISTING WATER PIPE			
EXISTING SEWER			
EXISTING STORM DRAIN			
EXISTING POWER POLE & GUY WIRE			
EXISTING SIGN			
EXISTING MANHOLE			
EXISTING STREET LIGHT			
EXISTING FENCE			
EXISTING TRAFFIC SIGNAL			
EXISTING VALVE BOX COVER			
EXISTING FIRE HYDRANT			

Revision	By	Apprvd	Date
New	SJ	GM	12/27/12
	GL	EA	05/16/14

CITY OF VISTA
 STANDARD DRAWING

STANDARD SEWER
LEGEND AND SYMBOLS

 CITY ENGINEER, DATE
 RCE 55075
 DRAWING NUMBER: **SWR-01**

POTABLE WATER/STORM DRAIN & SEWER MAINS SHALL BE INSTALLED IN SEPARATE TRENCHES. SEWERS SHALL BE INSTALLED AT LEAST TEN FEET (10') HORIZONTALLY FROM NEW OR EXISTING WATER MAINS AND/OR STORM DRAINS.

P A R A L L E L
CONSTRUCTION

PERPENDICULAR
CONSTRUCTION

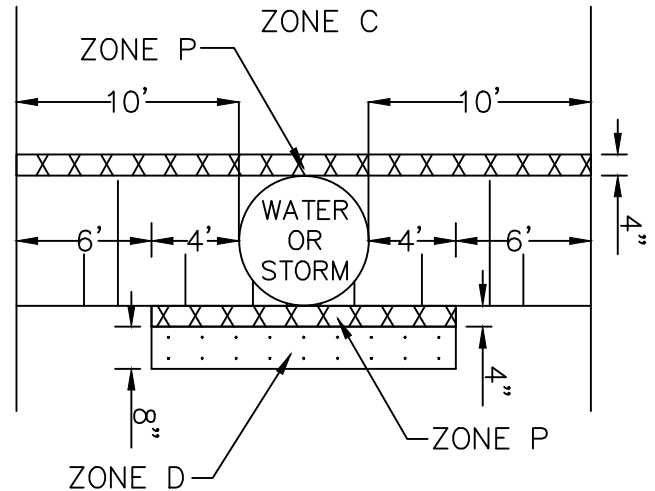
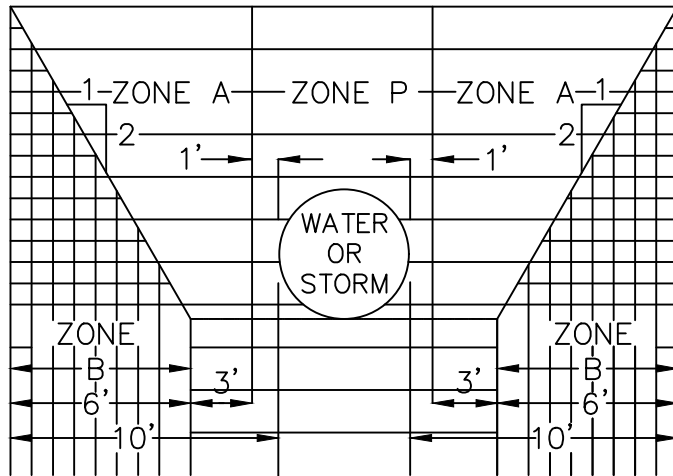

NOTES:

- 1] DIMENSIONS ARE FROM OUTSIDE OF WATER OR STORM DRAIN TO OUTSIDE OF SEWER MAIN.
- 2] SANITARY SEWERS ARE NOT PERMITTED WITHIN ANY OF THE ABOVE INDICATED ZONE UNLESS CONSTRUCTED IN CONFORMANCE WITH THE SPECIAL REQUIREMENTS SHOWN BELOW.

ZONE	SPECIAL SEWER CONSTRUCTION REQUIREMENTS
— A —	SEWER LINES WILL NOT BE PERMITTED IN THIS ZONE WITHOUT SPECIAL WRITTEN PERMISSION FROM THE DEPARTMENT OF HEALTH.
B	EXTRA-STRENGTH VITRIFIED CLAY WITH COMPRESSION JOINT; OR RUBBER-GASKETED PLASTIC PIPE (C-900, CL305).
C OR D	SEWER PIPE WITHIN A CONTINUOUS STEEL CASING CLEAR OF ZONE P. CASING SHALL HAVE A THICKNESS OF NOT LESS THAN ONE-FOURTH INCH (1/4") AND WITH ALL VOIDS BETWEEN SEWER PIPE AND CASING PRESSURE GROUTED WITH SAND CEMENT GROUT.
XXXXX	PROHIBITED ZONE. NO SEWER

Revision	By	Apprvd	Date	CITY OF VISTA STANDARD DRAWING	
New	SJ	GM	12/27/12		
Updated	GL	EA	05/07/14	SEWER, WATER, & STORM MAINLINE SEPARATION	CITY ENGINEER, DATE RCE 55075
Updated	SN	KK	05/23/23		DRAWING NUMBER: SWR-02

SEE SAN DIEGO REGIONAL STANDARD DRAWINGS:

SM-01 (48" DIAMETER PRECAST MANHOLE INSTALLATION),
SM-03 (SEWER MANHOLE BASE),
SM-04 (MANHOLE PIPE CONNECTORS)
 AND
SM-05 (MANHOLE MISCELLANEOUS DETAILS)

NOTES:

1. COV & BSD REQUIRE 60" MANHOLES PER SWR-04/SM-02 FOR NEW MANHOLE INSTALLATIONS. USE OF 48" MANHOLE RESERVED FOR AREAS OF UTILITY CONFLICT AND REQUIRE SEWER ENGINEERING MANAGER APPROVAL.
2. ALL MANHOLES TO BE EPOXY LINED (MIN. 125-MIL) WITH RAVEN 405 (OR APPROVED EQUAL) AND SPARK TESTED PER GREENBOOK SPECIFICATIONS.
3. MANHOLES CUT INTO MAINS WITH SPIRAL WOUND LINERS REQUIRE SPECIAL ATTENTION. CUT ENDS OF LINER TO BE GROUTED IN PLACE AND EPOXY SEALED TO PREVENT LINER SLIPPAGE AND FLOW OF EFFLUENT INTO ANNULAR SPACE.

Revision	By	Apprvd	Date	CITY OF VISTA STANDARD DRAWING	
New	SJ	GM	12/27/12		
Updated	SN	KK	05/23/23	STANDARD SEWER PRECAST CONCRETE MANHOLE (4' Ø)	CITY ENGINEER, DATE RCE 55075
					DRAWING NUMBER: SWR-03

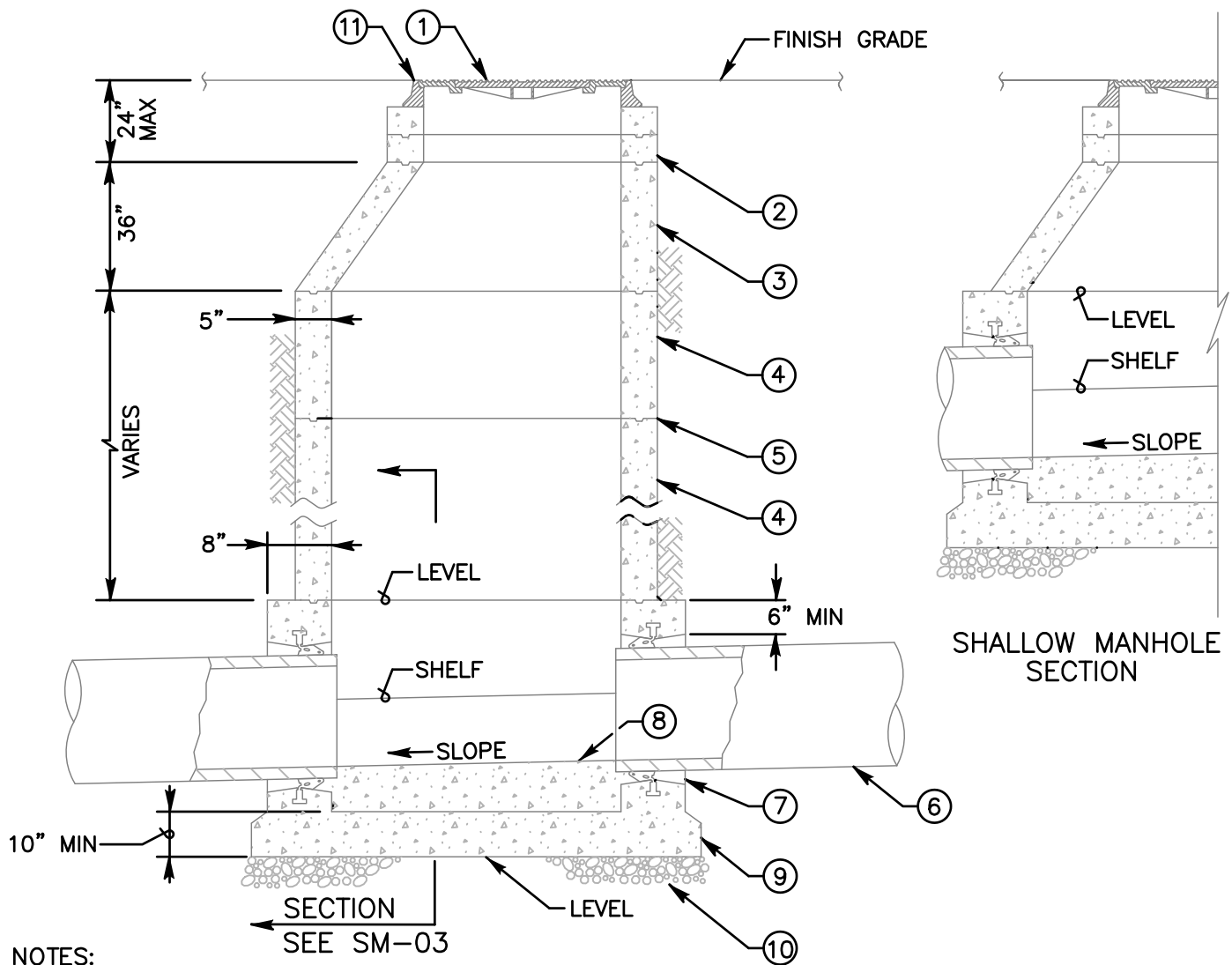

NOTES:

- 1) REFER TO AGENCY SPECIFICATIONS WHERE APPLICABLE
- 2) VERTICAL WALL OF CONE TO BE ON THE UPSTREAM SIDE OF MANHOLE SEE SM-05 FOR ACCESS LOCATIONS
- 3) FOR MANHOLE BASES SEE SM-03
- 4) MANHOLES FOR MAINS 18" AND LARGER SHALL BE COATED AND LINED PER SM-07
- 5) MATERIALS SHALL BE SELECTED FROM THE AGENCY'S APPROVED MATERIALS LIST

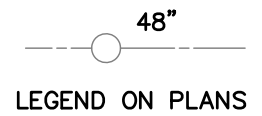

ITEM NO	SIZE AND DESCRIPTION	ITEM NO	SIZE AND DESCRIPTION
①	36" MANHOLE FRAME AND TWO CONCENTRIC COVERS SEE S.D.R.S.D. M-3	⑦	MANHOLE PIPE CONNECTOR SEE SM-04
②	36" DIA GRADE RING(S) 6" TO 18" HIGH	⑧	FIELD INSTALLED INVERT SEE SM-04
③	ECCENTRIC CONE SEE NOTE 2	⑨	CONCRETE BASE, PRECAST OR CAST IN PLACE
④	48" DIA RING(S) VARIABLE HEIGHT	⑩	6" OF 3/4" CRUSHED ROCK
⑤	WATER TIGHT JOINTS SEE SM-05	⑪	MANHOLE DETAIL SEE SM-05
⑥	SEWER MAIN		

Revision	By	Approved	Date	SAN DIEGO REGIONAL STANDARD DRAWING	RECOMMENDED BY THE SAN DIEGO REGIONAL STANDARDS COMMITTEE
ORIGINAL		Kercheval	12/75		
Reviewed	BK	B. KNOLL	04/15	48" DIAMETER PRECAST MANHOLE INSTALLATION	Chairperson R.C.E. 52241 Date 03/24/2022
Reviewed	BK	B. KNOLL	10/18		
Reviewed	RP	S. Engeda	03/22		
				DRAWING NUMBER	SM-01

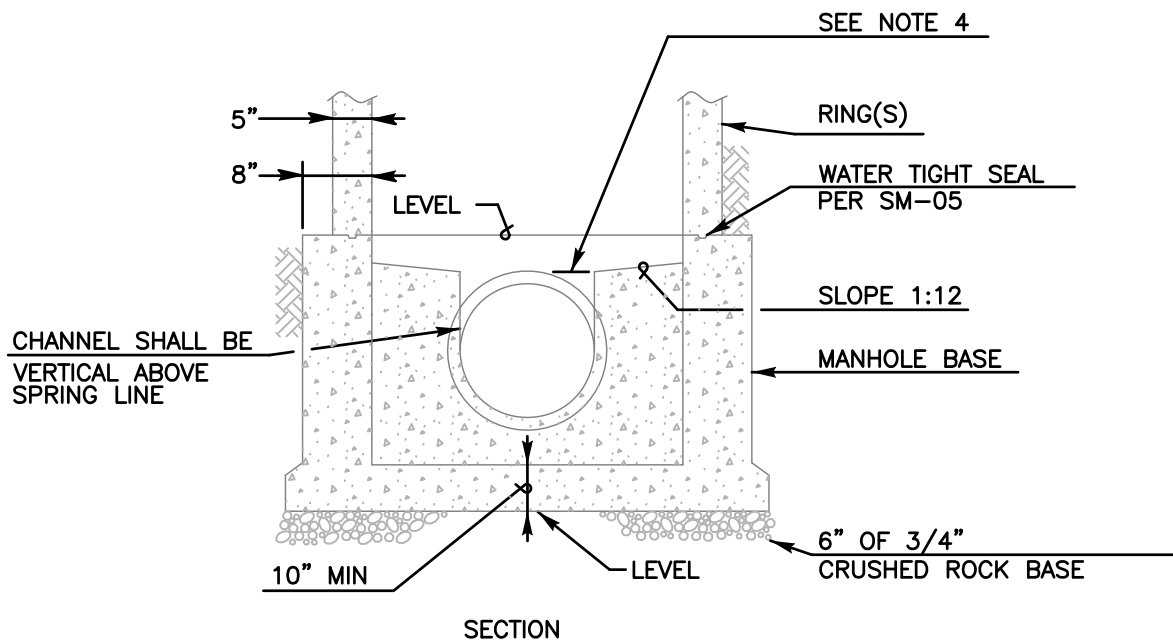

NOTES:

- 1) REFER TO AGENCY SPECIFICATIONS WHERE APPLICABLE
- 2) FOR MANHOLE INSTALLATIONS SEE SM-01 AND SM-02
- 3) MANHOLE BASES FOR MAINS 18" AND LARGER SHALL BE COATED PER SM-07
- 4) LOWEST POINT ON SHELF SHALL BE EVEN WITH TOP OF PIPE
- 5) MATERIALS SHALL BE SELECTED FROM THE AGENCY'S APPROVED MATERIALS LIST

Revision	By	Approved	Date	SAN DIEGO REGIONAL STANDARD DRAWING	RECOMMENDED BY THE SAN DIEGO REGIONAL STANDARDS COMMITTEE
ORIGINAL		Kercheval	12/75		SEWER MANHOLE BASE
Reviewed	BK	B. KNOLL	04/15	Chairperson R.C.E. 52241 Date	
Reviewed	BK	B. KNOLL	10/18	DRAWING NUMBER	
Reviewed	RP	S. Engeda	03/22	SM-03	

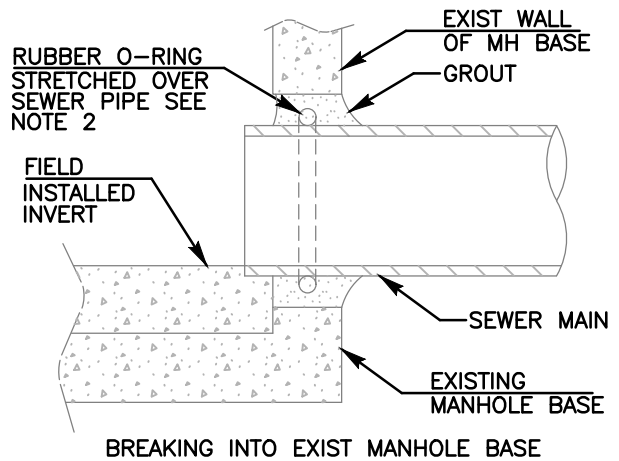
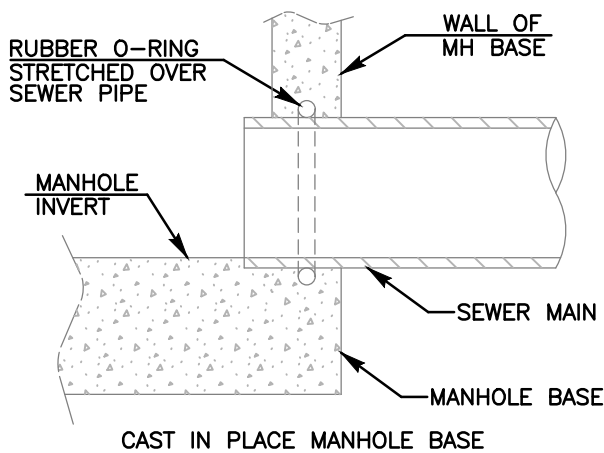
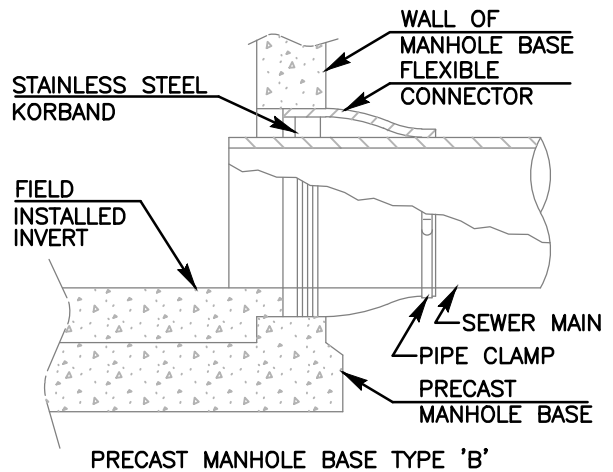
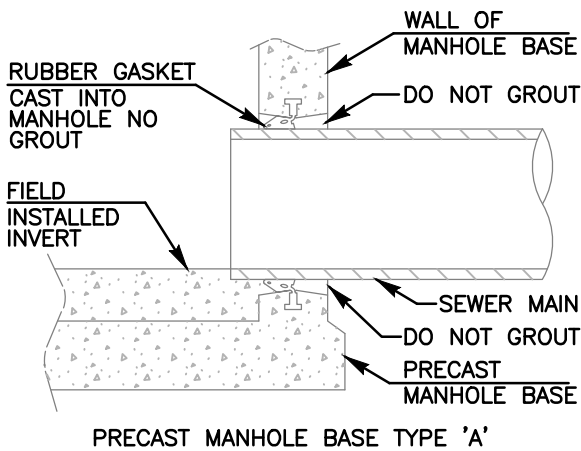

NOTES:

- 1) REFER TO AGENCY SPECIFICATIONS WHERE APPLICABLE
- 2) A RUBBER O-RING OR A FLEXIBLE CONNECTOR (AS SHOWN IN PRECAST MANHOLE BASE TYPE 'B') CAN BE USED WHEN BREAKING INTO EXISTING MANHOLE
- 3) FOR MANHOLES REQUIRING COATING AND LINING SEE SM-07
- 4) MATERIALS SHALL BE SELECTED FROM THE AGENCY'S APPROVED MATERIALS LIST

Revision	By	Approved	Date	SAN DIEGO REGIONAL STANDARD DRAWING		RECOMMENDED BY THE SAN DIEGO REGIONAL STANDARDS COMMITTEE	
ORIGINAL		Kercheval	12/75	MANHOLE PIPE CONNECTORS		<i>Somesh Engeda</i> 03/24/2022	
Reviewed	BK	B. KNOLL	04/15			Chairperson R.C.E. 52241	Date
Reviewed	BK	B. KNOLL	10/18				
Reviewed	RP	S. Engeda	03/22				
						DRAWING NUMBER SM-04	

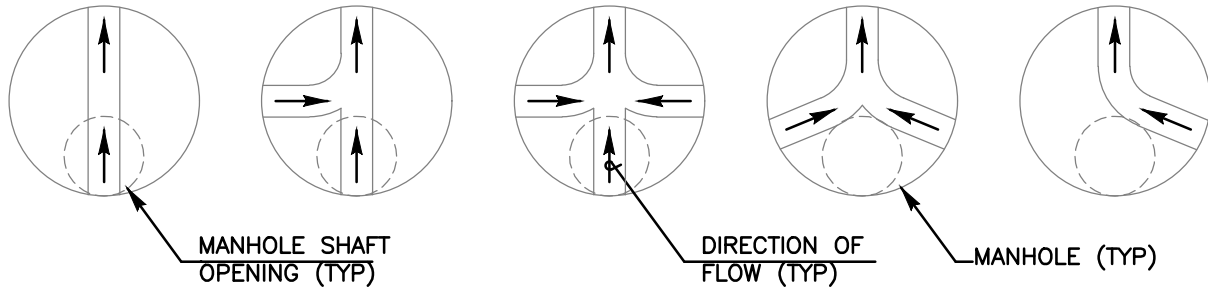

MANHOLE ACCESS LOCATION PLAN VIEW

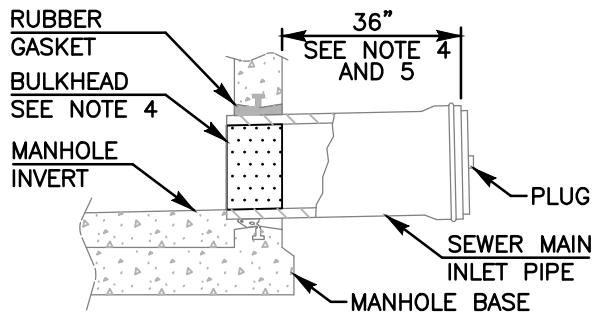

MANHOLE STUB OUT FOR FUTURE CONNECTION

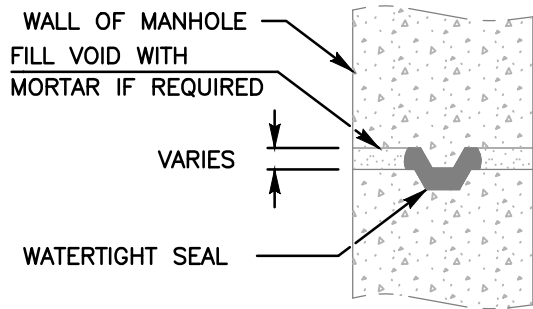

WATERTIGHT MANHOLE JOINT

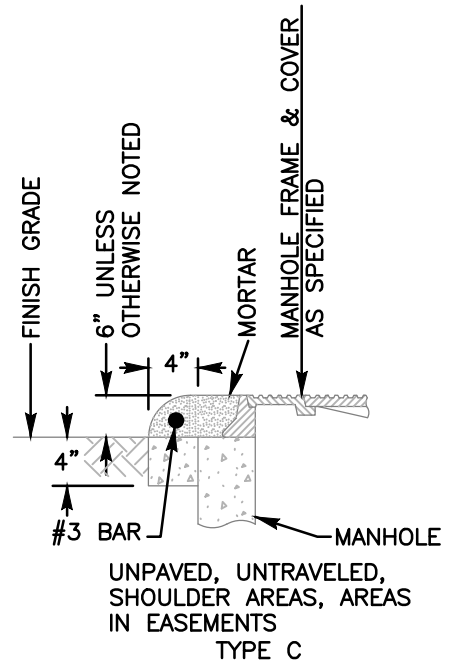
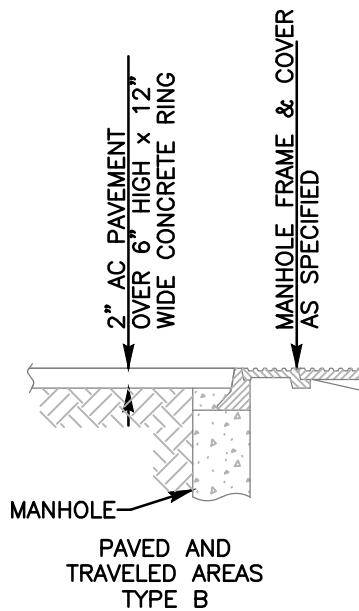
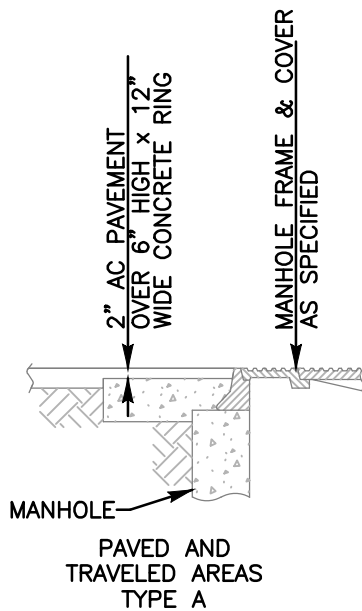

NOTES:

- 1) REFER TO AGENCY SPECIFICATIONS WHERE APPLICABLE
- 2) VERTICAL WALL OF CONE TO BE ON THE UP STREAM SIDE OF MANHOLE
- 3) FOR MANHOLES REQUIRING COATING AND LINING SEE SM-07
- 4) STUBS SHALL BE BULKHEADED AT THE MANHOLE END
- 5) SEWER MAIN TO BE LAID WITH BELLS UP-GRADE
- 6) MATERIALS SHALL BE SELECTED FROM THE AGENCY'S APPROVED MATERIALS LIST

Revision	By	Approved	Date	SAN DIEGO REGIONAL STANDARD DRAWING		RECOMMENDED BY THE SAN DIEGO REGIONAL STANDARDS COMMITTEE
ORIGINAL		Kercheval	12/75	MANHOLE MISCELLANEOUS DETAILS		<i>Samantha Engeda</i> 03/24/2022 Chairperson R.C.E. 52241 Date
Reviewed	BK	B. KNOLL	04/15			
Reviewed	BK	B. KNOLL	10/18			
Reviewed	RP	S. Engeda	03/22			
				DRAWING NUMBER	SM-05	

SEE SAN DIEGO REGIONAL STANDARD DRAWINGS:

SM-02 (60" DIAMETER PRECAST MANHOLE INSTALLATION),
SM-03 (SEWER MANHOLE BASE),
SM-04 (MANHOLE PIPE CONNECTORS)
AND
SM-05 (MANHOLE MISCELLANEOUS DETAILS)

NOTES:

1. ALL MANHOLES TO BE EPOXY LINED (MIN. 125-MIL) WITH RAVEN 405 (OR APPROVED EQUAL) AND SPARK TESTED PER GREENBOOK SPECIFICATIONS.
2. MANHOLES CUT INTO MAINS WITH SPIRAL WOUND LINERS REQUIRE SPECIAL ATTENTION. CUT ENDS OF LINER TO BE GROUTED IN PLACE AND EPOXY SEALED TO PREVENT LINER SLIPPAGE AND FLOW OF EFFLUENT INTO ANNULAR SPACE.

Revision	By	Apprvd	Date	CITY OF VISTA STANDARD DRAWING	
New	SJ	GM	12/27/12		
Updated	SN	KK	05/23/23	STANDARD SEWER PRECAST CONCRETE MANHOLE (5' Ø)	CITY ENGINEER, DATE RCE 55075
					DRAWING NUMBER: SWR-04

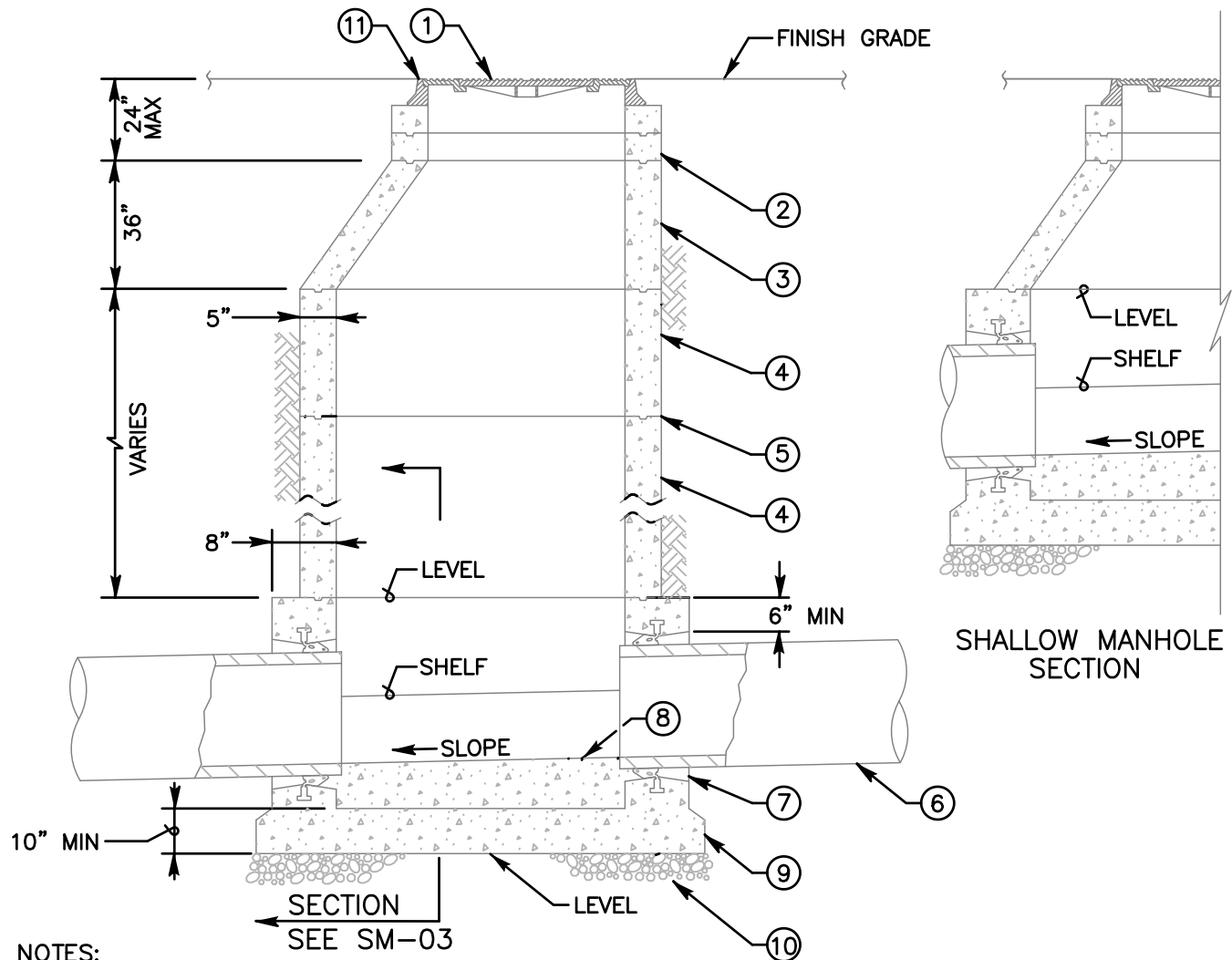

NOTES:

- 1) REFER TO AGENCY SPECIFICATIONS WHERE APPLICABLE
- 2) VERTICAL WALL OF CONE TO BE ON THE UPSTREAM SIDE OF MANHOLE SEE SM-05 FOR ACCESS LOCATIONS
- 3) FOR MANHOLE BASES SEE SM-03
- 4) MANHOLES FOR MAINS 18" AND LARGER SHALL BE COATED AND LINED PER SM-07
- 5) MATERIALS SHALL BE SELECTED FROM THE AGENCY'S APPROVED MATERIALS LIST

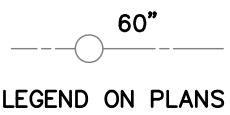

ITEM NO	SIZE AND DESCRIPTION	ITEM NO	SIZE AND DESCRIPTION
①	36" MANHOLE FRAME AND TWO CONCENTRIC COVERS SEE S.D.R.S.D. M-3	⑦	MANHOLE PIPE CONNECTOR SEE SM-04
②	36" DIA GRADE RING(S) 6" TO 18" HIGH	⑧	FIELD INSTALLED INVERT SEE SM-04
③	ECCENTRIC CONE SEE NOTE 2	⑨	CONCRETE BASE, PRECAST OR CAST IN PLACE
④	60" DIA RING(S) VARIABLE HEIGHT	⑩	6" OF 3/4" CRUSHED ROCK
⑤	WATER TIGHT JOINTS SEE SM-05	⑪	MANHOLE DETAIL SEE SM-05
⑥	SEWER MAIN		

Revision	By	Approved	Date	SAN DIEGO REGIONAL STANDARD DRAWING	RECOMMENDED BY THE SAN DIEGO REGIONAL STANDARDS COMMITTEE
ORIGINAL		Kercheval	12/75		
Reviewed	BK	B. KNOLL	04/15	60" DIAMETER PRECAST MANHOLE INSTALLATION	 03/24/2022 Chairperson R.C.E. 52241 Date
Reviewed	BK	B. KNOLL	10/18		
Reviewed	RP	S. Engeda	03/22		
				DRAWING NUMBER	SM-02

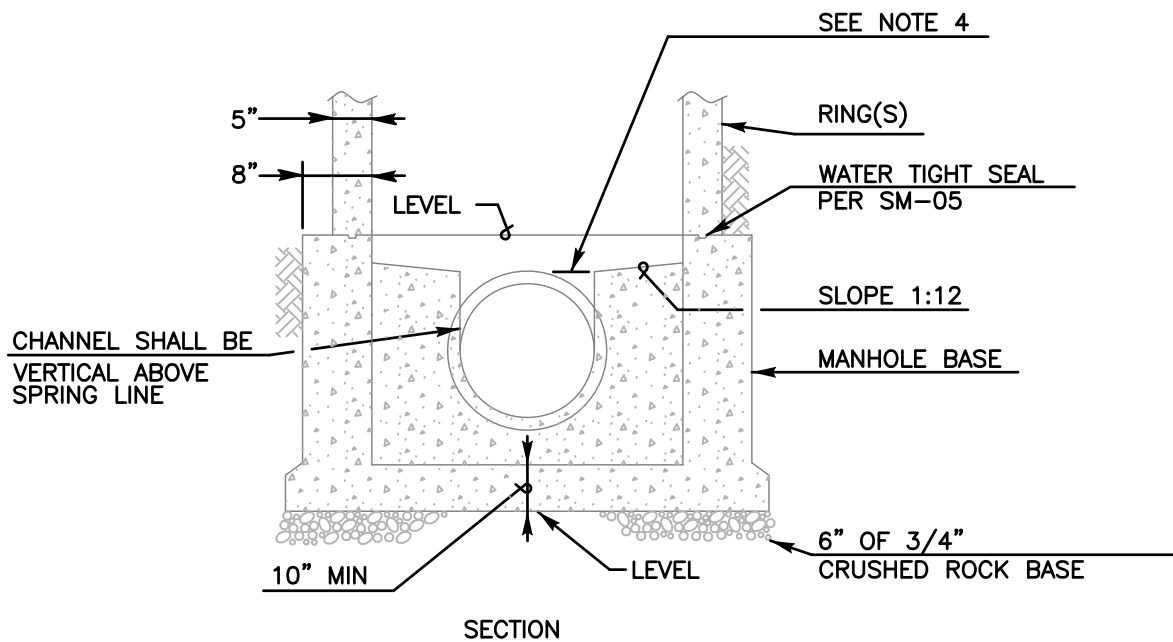

NOTES:

- 1) REFER TO AGENCY SPECIFICATIONS WHERE APPLICABLE
- 2) FOR MANHOLE INSTALLATIONS SEE SM-01 AND SM-02
- 3) MANHOLE BASES FOR MAINS 18" AND LARGER SHALL BE COATED PER SM-07
- 4) LOWEST POINT ON SHELF SHALL BE EVEN WITH TOP OF PIPE
- 5) MATERIALS SHALL BE SELECTED FROM THE AGENCY'S APPROVED MATERIALS LIST

Revision	By	Approved	Date	SAN DIEGO REGIONAL STANDARD DRAWING		RECOMMENDED BY THE SAN DIEGO REGIONAL STANDARDS COMMITTEE
ORIGINAL		Kercheval	12/75	SEWER MANHOLE BASE		 03/24/2022 Chairperson R.C.E. 52241 Date
Reviewed	BK	B. KNOLL	04/15			
Reviewed	BK	B. KNOLL	10/18			
Reviewed	RP	S. Engeda	03/22			
						DRAWING NUMBER SM-03

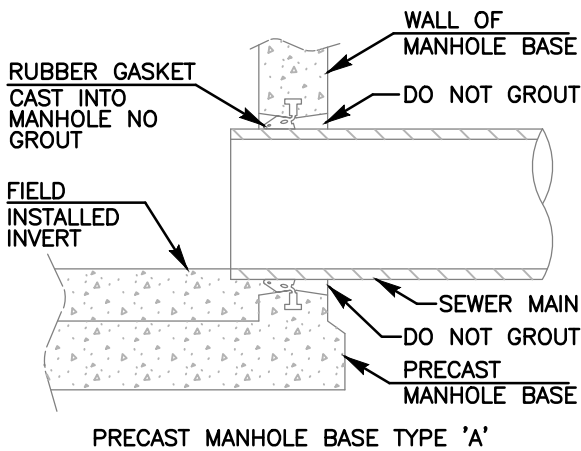

PRECAST MANHOLE BASE TYPE 'A'

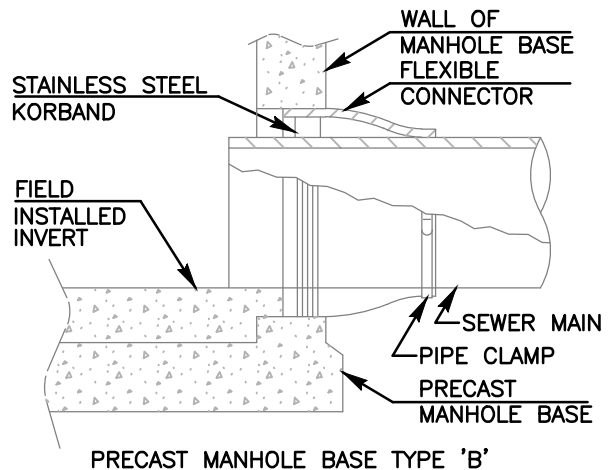

PRECAST MANHOLE BASE TYPE 'B'

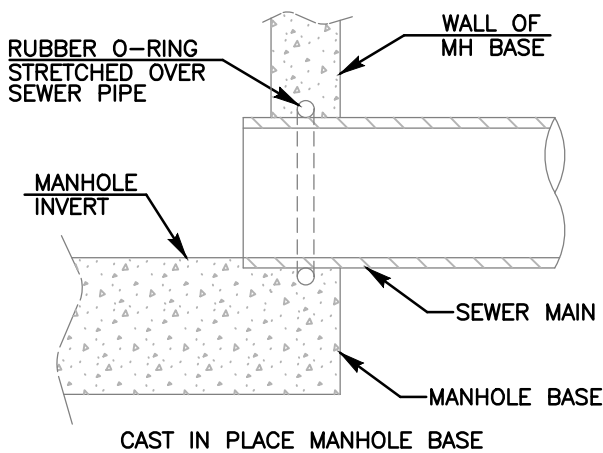

CAST IN PLACE MANHOLE BASE

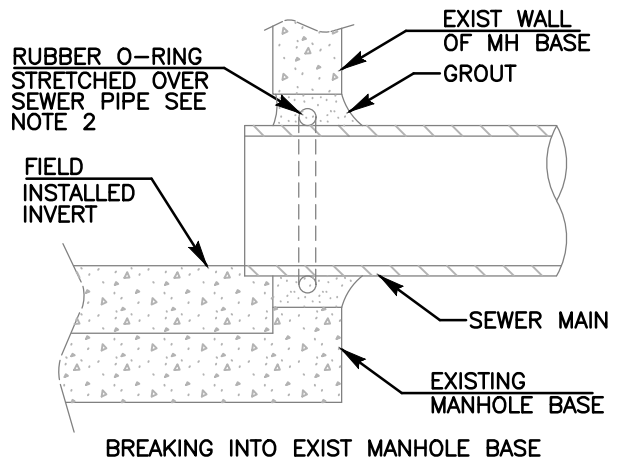

BREAKING INTO EXIST MANHOLE BASE

NOTES:

- 1) REFER TO AGENCY SPECIFICATIONS WHERE APPLICABLE
- 2) A RUBBER O-RING OR A FLEXIBLE CONNECTOR (AS SHOWN IN PRECAST MANHOLE BASE TYPE 'B') CAN BE USED WHEN BREAKING INTO EXISTING MANHOLE
- 3) FOR MANHOLES REQUIRING COATING AND LINING SEE SM-07
- 4) MATERIALS SHALL BE SELECTED FROM THE AGENCY'S APPROVED MATERIALS LIST

Revision	By	Approved	Date	SAN DIEGO REGIONAL STANDARD DRAWING		RECOMMENDED BY THE SAN DIEGO REGIONAL STANDARDS COMMITTEE	
ORIGINAL		Kercheval	12/75	MANHOLE PIPE CONNECTORS		<i>Somesh Engeda</i> 03/24/2022	
Reviewed	BK	B. KNOLL	04/15			Chairperson R.C.E. 52241	Date
Reviewed	BK	B. KNOLL	10/18				
Reviewed	RP	S. Engeda	03/22				
						DRAWING NUMBER SM-04	

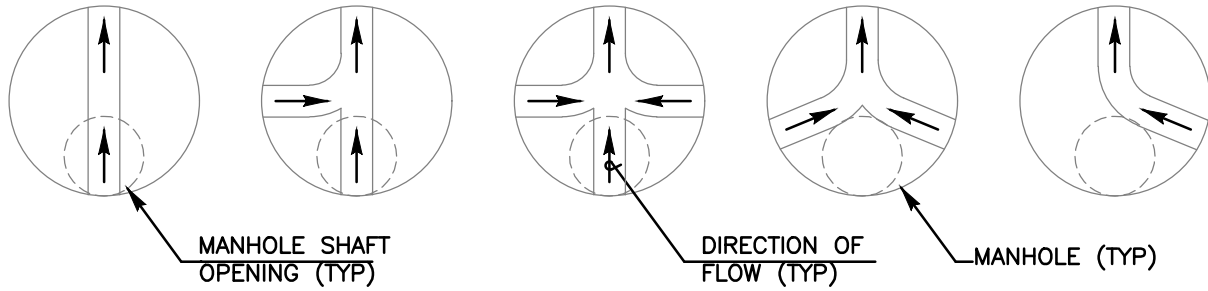

MANHOLE ACCESS LOCATION PLAN VIEW

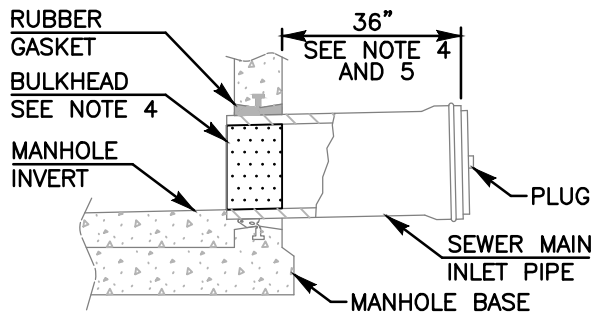

MANHOLE STUB OUT FOR FUTURE CONNECTION

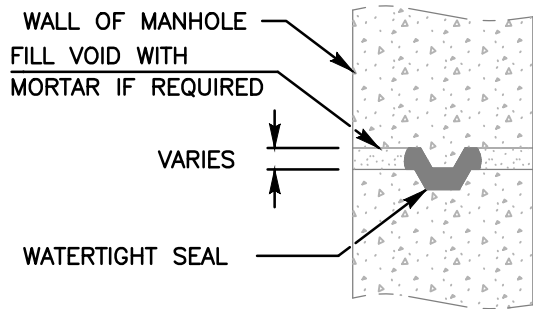

WATERTIGHT MANHOLE JOINT

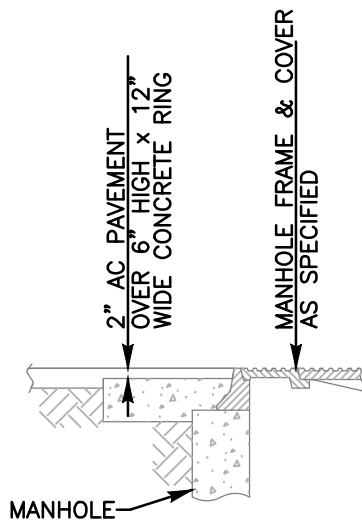

PAVED AND TRAVELED AREAS TYPE A

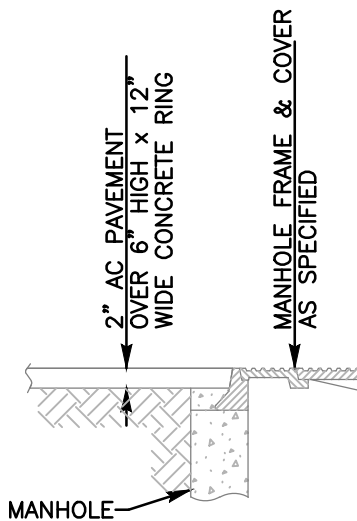

PAVED AND TRAVELED AREAS TYPE B

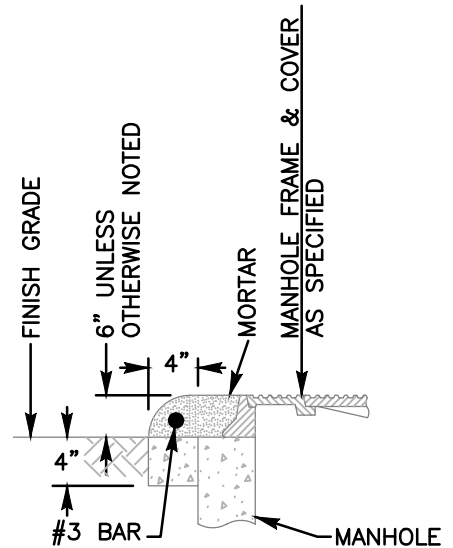

UNPAVED, UNTRAVELED, SHOULDER AREAS, AREAS IN EASEMENTS TYPE C

NOTES:

- 1) REFER TO AGENCY SPECIFICATIONS WHERE APPLICABLE
- 2) VERTICAL WALL OF CONE TO BE ON THE UP STREAM SIDE OF MANHOLE
- 3) FOR MANHOLES REQUIRING COATING AND LINING SEE SM-07
- 4) STUBS SHALL BE BULKHEADED AT THE MANHOLE END
- 5) SEWER MAIN TO BE LAID WITH BELLS UP-GRADE
- 6) MATERIALS SHALL BE SELECTED FROM THE AGENCY'S APPROVED MATERIALS LIST

Revision	By	Approved	Date	SAN DIEGO REGIONAL STANDARD DRAWING		RECOMMENDED BY THE SAN DIEGO REGIONAL STANDARDS COMMITTEE
ORIGINAL		Kercheval	12/75	MANHOLE MISCELLANEOUS DETAILS		<i>Samantha Engeda</i> 03/24/2022 Chairperson R.C.E. 52241 Date
Reviewed	BK	B. KNOLL	04/15			
Reviewed	BK	B. KNOLL	10/18			
Reviewed	RP	S. Engeda	03/22			
						DRAWING NUMBER SM-05

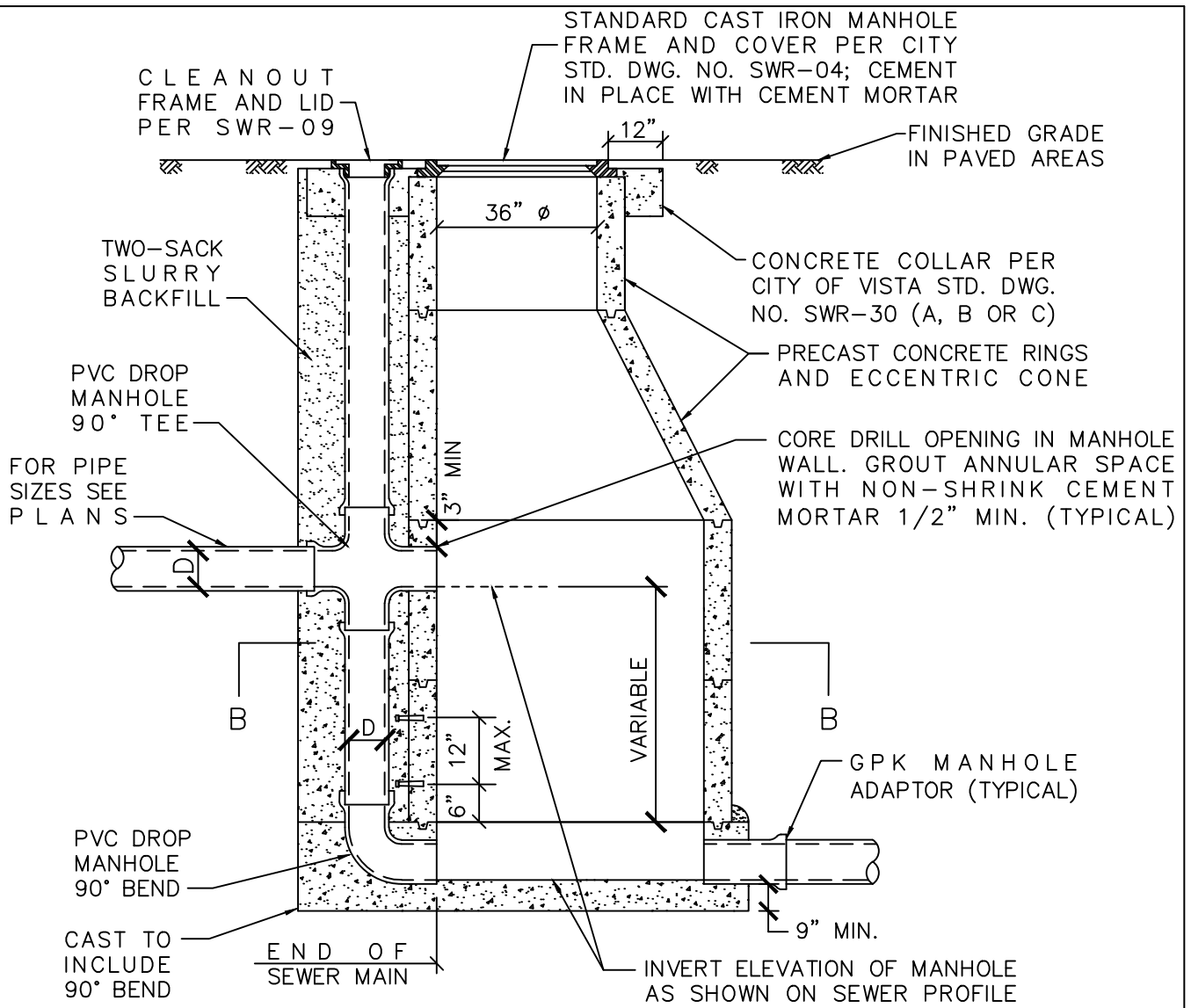

NOTES:

1. DROP MANHOLE SHALL BE IDENTICAL TO STANDARD CONCRETE MANHOLE, EXCEPT FOR PIPE DETAILS AS SHOWN.
2. THE DROP MANHOLE TEE SHALL ENTER THE 5' ϕ RING; SEAL WALL PENETRATION PER SDRSD SM-04.
3. CLEAN AND ROUGHEN OUTSIDE SURFACE OF RINGS AND APPLY BONDING AGENT CEMENT PRIOR TO POURING SUPPORT FOR DROP SECTION.
4. NO MANHOLE STEPS ALLOWED.
5. DROP MANHOLES SHALL BE INSTALLED ONLY WITH PRIOR APPROVAL OF THE CITY OR DISTRICT. NO INTERNAL DROP PERMITTED.
6. MANHOLE TO BE EPOXY LINED (MIN. 125-MIL) WITH RAVEN 405 (OR APPROVED EQUAL) AND SPARK TESTED PER GREENBOOK SPECIFICATIONS.

SECTION A-A

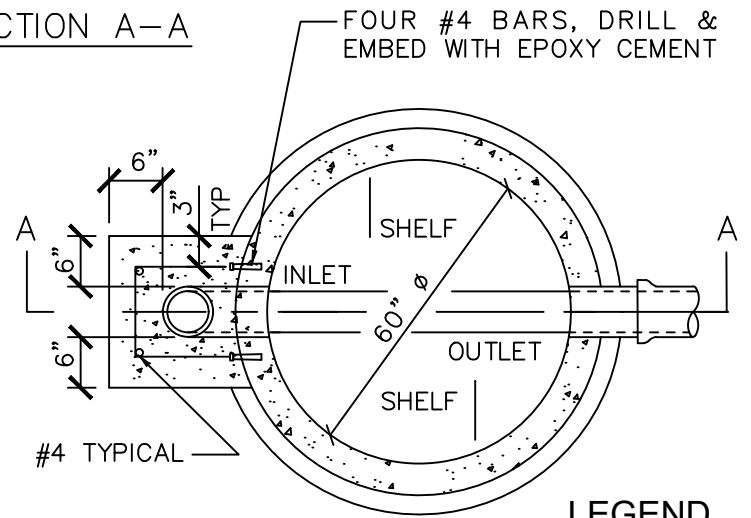

SECTION B-B

LEGEND

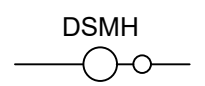

Revision	By	Apprvd	Date
New	SJ	GM	12/27/12
Updated	SN	KK	05/23/23

CITY OF VISTA
 STANDARD DRAWING
STANDARD SEWER CONCRETE
DROP MANHOLE

 CITY ENGINEER, DATE
 RCE 55075
 DRAWING NUMBER: **SWR-05A**

NOTES:

1. ALL PORTLAND CEMENT CONCRETE SHALL CONFORM TO THE PROVISIONS OF SECTIONS 201, 202 AND 303 OF THE LATEST EDITION OF THE STANDARD SPECIFICATIONS FOR PUBLIC WORKS CONSTRUCTION (GREENBOOK).
2. CLASS 560-C-3250 CONCRETE WITH TYPE V CEMENT, AS DESCRIBED IN SECTION 201 OF THE GREENBOOK SHALL BE USED FOR ALL MANHOLE BASES UNLESS OTHERWISE DIRECTED BY THE CITY ENGINEER. THE MAXIMUM WATER / CEMENT RATIO SHALL BE 0.53 BY WEIGHT AND THE MAXIMUM SLUMP SHALL BE FOUR TO SIX INCHES (4" - 6"). IN CERTAIN CIRCUMSTANCES, RAPID-SETTING CONCRETE MAY BE REQUIRED. ACCELERATING ADMIXTURES SHALL CONFORM TO ASTM C-494 AND MAY BE USED IN THE CONCRETE MIX AS PERMITTED BY THE CITY ENGINEER. CALCIUM CHLORIDE SHALL NOT BE USED IN CONCRETE. HAND MIXED CONCRETE MATERIALS TYPE AND PROPORTIONS SHALL BE SUBMITTED AND APPROVED BY THE CITY ENGINEER PRIOR TO APPLICATION ON SITE.
3. ALL PRECAST COMPONENTS SHALL BE MANUFACTURED IN ACCORDANCE WITH ASTM C-478.
4. VERTICAL WALL OF THE CONE SHALL BE ON THE UPSTREAM SIDE OF THE MANHOLE.
5. REFER TO SDRSD SM-01 THROUGH SM-08 & M-3 FOR ALL OTHER PERTINENT CONSTRUCTION DATA.
6. MANHOLE INSTALLATION WILL REQUIRE 1.5" A.C. OVER A 12" WIDE BY 12" THICK CONCRETE COLLAR AROUND THE MANHOLE (MINIMUM).
7. DROP MANHOLES EXCEEDING TWENTY FEET (20') IN DEPTH SHALL BE DESIGNED WITH THICKER WALLS AND THICKER BASE.
8. PLACE BASE AGAINST A SIX INCH (6") LAYER OF 3/4" CRUSHED ROCK.
9. MANHOLE FRAMES SHALL BE SET IN CLASS 'C' MORTAR AND CONFORM TO THE PROVISIONS OF SUBSECTION 201-5 OF THE LATEST EDITION OF THE GREENBOOK. ALL JOINTS SHALL BE SET IN MASTIC AND CONFORM TO THE PROVISIONS OF SUBSECTION 207 OF THE GREENBOOK.
10. ALL PATCHING WITHIN MANHOLE BASE SHALL BE WITH A TWO-COMPONENT, POLYMER-MODIFIED, PORTLAND CEMENT, FAST SETTING, NON-SAG EPOXY MORTAR WITH A PENETRATING CORROSION INHIBITOR (e.g. SIKATOP 123 PLUS).
11. GPK SAND COLLAR MANHOLE ADAPTERS (OR APPROVED EQUAL) SHALL BE UTILIZED FOR ALL MANHOLE CONNECTIONS.
12. ALL MANHOLES TO BE EPOXY LINED (MIN. 125-MIL) WITH RAVEN 405 (OR APPROVED EQUAL) AND SPARK TESTED PER GREENBOOK SPECIFICATIONS.

Revision	By	Apprvd	Date	CITY OF VISTA STANDARD DRAWING	
New	SJ	GM	12/27/12		
Updated	SN	KK	05/23/23	STANDARD SEWER PRECAST CONCRETE MANHOLE NOTES	CITY ENGINEER, DATE RCE 55075
					DRAWING NUMBER: SWR-05B

**SEE SAN DIEGO REGIONAL STANDARD DRAWING:
M-1 (24" MANHOLE FRAME AND COVER HEAVY DUTY)**

NOTE: COV & BSD REQUIRE 36" MANHOLE FRAME AND COVER PER SWR-07/M-3 FOR NEW AND REHAB MANHOLE INSTALLATIONS. USE OF 24" MANHOLE FRAME AND COVER RESERVED FOR AREAS OF UTILITY CONFLICT AND REQUIRE SEWER ENGINEERING MANAGER APPROVAL. PUBLIC AND PRIVATE MANHOLES COVERS TO BE CAST WITH "CITY OF VISTA - SEWER", "BUENA SANITATION DISTRICT - SEWER", OR "PRIVATE - SEWER", RESPECTIVELY.

Revision	By	Apprvd	Date	CITY OF VISTA STANDARD DRAWING		
New	SJ	GM	12/27/12			
Updated	SN	KK	05/23/23	DRAWING NUMBER: SWR-06		

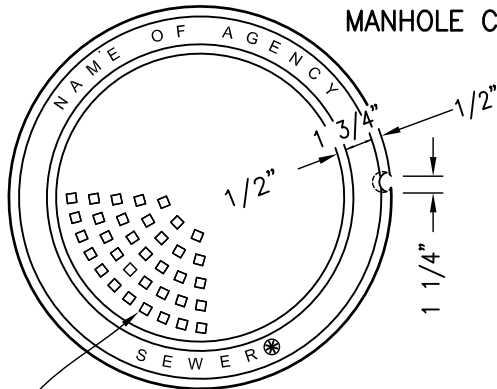
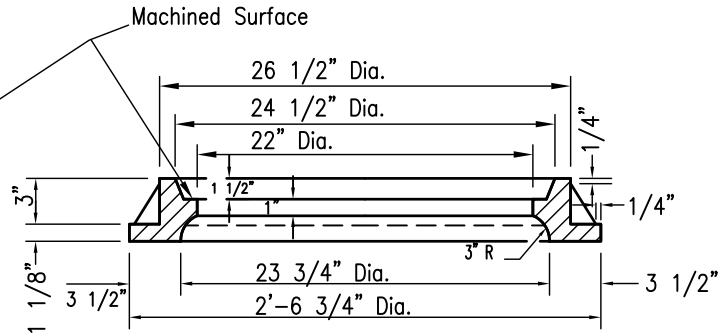
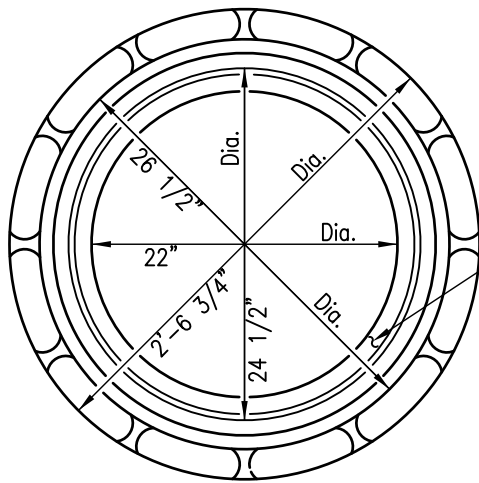

MANHOLE COVER FRAME

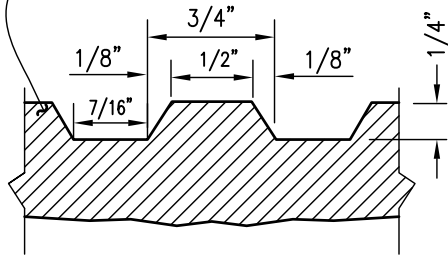
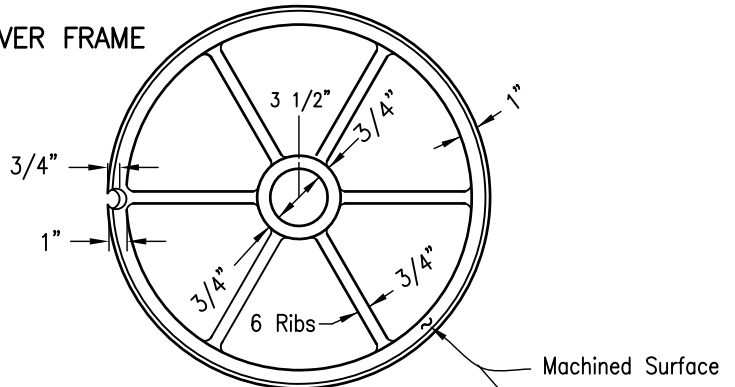

DETAIL

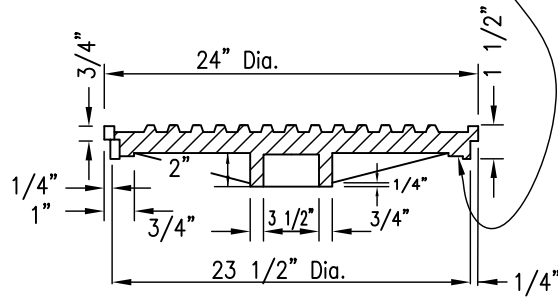

MANHOLE COVER

NOTES

1. Frame and cover shall be cast iron. Cast iron shall conform to ASTM 48, Class 35B.
2. Weights: Frame 166 lbs – 193 lbs.
Cover 147 lbs – 171 lbs.
3. Machine all matching surfaces and seats of frame and cover to prevent rocking.
4. Imported frames and covers shall have the country of origin marked in compliance with federal regulations.

FOR	MARK
Sewer Projects	Sewer
Storm Drain Projects	Storm Drain
Water Projects	Water

Revision	By	Approved	Date
ORIGINAL		Kercheval	12/75
Reviewed		T. Stanton	10/18
Reviewed	RP	S. Engeda	03/22

SAN DIEGO REGIONAL STANDARD DRAWING

**24" MANHOLE FRAME AND COVER
HEAVY DUTY**

RECOMMENDED BY THE SAN DIEGO REGIONAL STANDARDS COMMITTEE

Samsir Engeda 03/24/2022
Chairperson R.C.E. 52241 Date

DRAWING NUMBER **M-01**

SEE SAN DIEGO REGIONAL STANDARD DRAWING:

**M-3 (36" MANHOLE FRAME AND TWO
CONCENTRIC COVERS HEAVY DUTY)**

NOTE: PUBLIC AND PRIVATE MANHOLES COVERS TO BE CAST WITH "CITY OF VISTA - SEWER", "BUENA SANITATION DISTRICT - SEWER", OR "PRIVATE - SEWER", RESPECTIVELY.

Revision	By	Apprvd	Date	CITY OF VISTA STANDARD DRAWING 36" Ø SEWER MANHOLE FRAME AND TWO CONCENTRIC COVERS (HEAVY DUTY)	 CITY ENGINEER, DATE RCE 55075 DRAWING NUMBER: SWR-07
New	SJ	GM	12/27/12		
Updated	SN	KK	05/23/23		

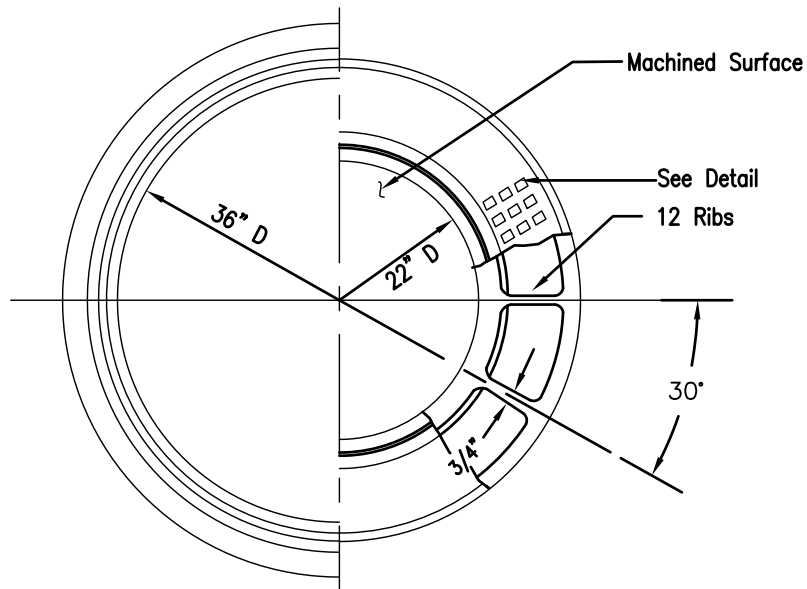

HALF PLAN FRAME & COVER

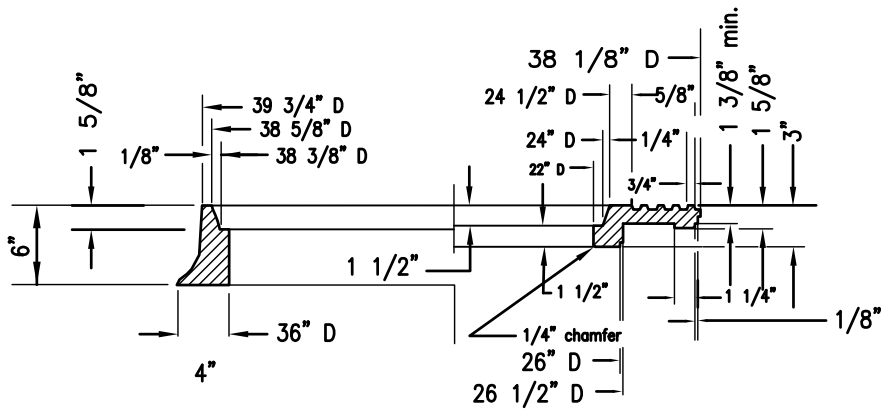

HALF SECTION FRAME & COVER

NOTES

1. Frame and cover shall be cast iron. Cast iron shall conform to ASTM 48, Class 35B.
2. Weights: Frame 314 lbs - 363 lbs.
Outer Cover 285 lbs - 330 lbs.
Inner Cover 147 lbs - 171 lbs.
3. Machine all matching surfaces and seats of frame and cover to prevent rocking.
4. Imported frames and covers shall have the country of origin marked in compliance with federal regulations.

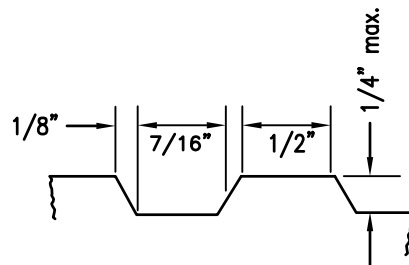

DETAIL

Revision	By	Approved	Date
Updated	DG	T. Stanton	12/15
Reviewed	DG	T. Stanton	10/18
Reviewed	RP	S. Engeda	03/22

SAN DIEGO REGIONAL STANDARD DRAWING

**36" MANHOLE FRAME
AND TWO CONCENTRIC COVERS
HEAVY DUTY**

RECOMMENDED BY THE SAN DIEGO REGIONAL STANDARDS COMMITTEE

Samantha Engeda 03/24/2022
Chairperson R.C.E. 52241 Date

DRAWING NUMBER **M-03A**

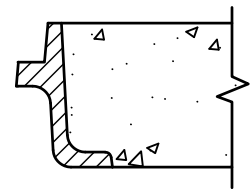
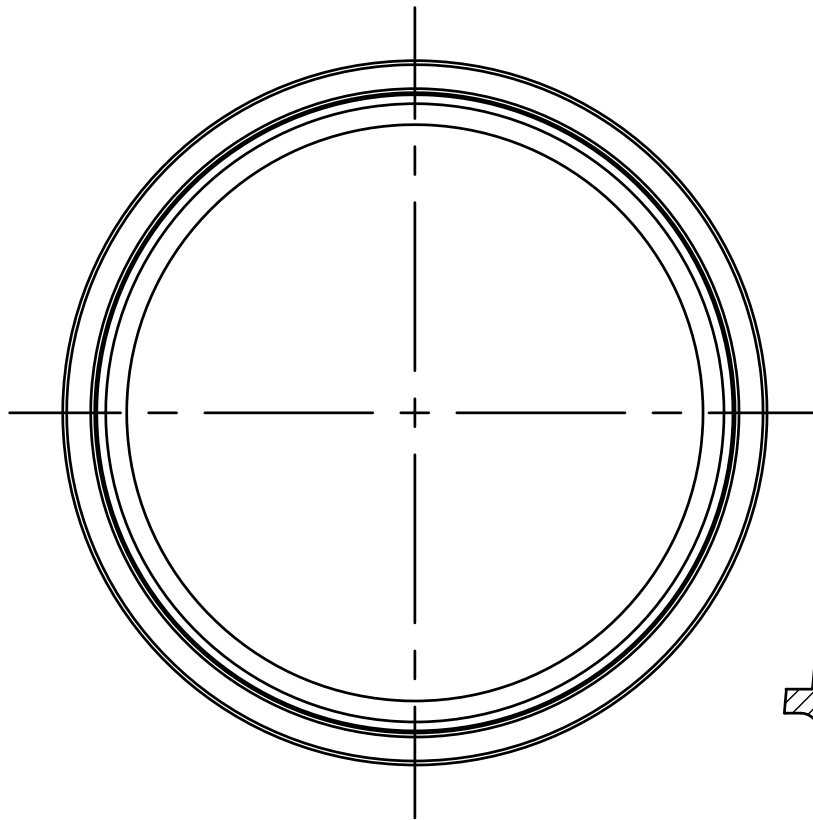

DETAIL OF AC PAVING

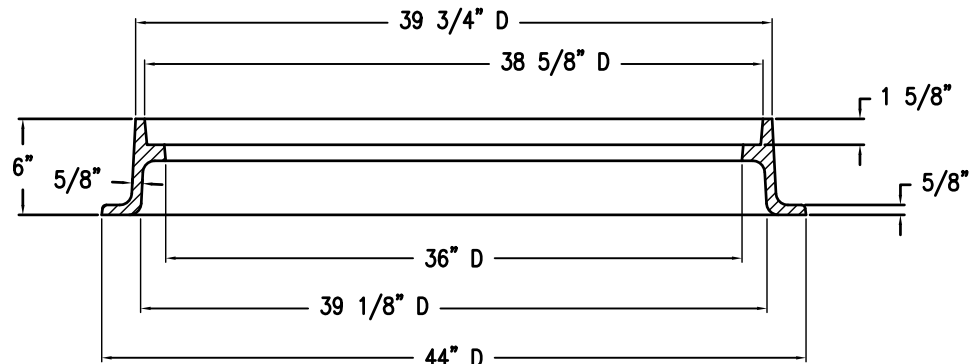

NOTES

1. FRAME SHALL BE CAST IRON. CAST IRON SHALL CONFORM TO ASTM 48, CLASS 35B.
2. WEIGHT: FRAME 212 LBS.
3. USE COVER SHOWN ON M-03A.
4. MACHINE ALL MATCHING SURFACES AND SEATS OF FRAME AND COVER TO PREVENT ROCKING.
5. IMPORTED FRAMES AND COVERS SHALL HAVE THE COUNTRY OF ORIGIN MARKED IN COMPLIANCE WITH FEDERAL REGULATIONS.
6. COVER CANNOT BE BOLTED TO THIS FRAME.

Revision	By	Approved	Date	SAN DIEGO REGIONAL STANDARD DRAWING	RECOMMENDED BY THE SAN DIEGO REGIONAL STANDARDS COMMITTEE
Updated	DG	T. Stanton	12/15		
Reviewed	DG	T. Stanton	10/18	36" MANHOLE FRAME LIGHTWEIGHT - HEAVY DUTY	<i>Samsir Engeda</i> 03/24/2022
Reviewed	RP	S. Engeda	03/22		Chairperson R.C.E. 52241 Date
					DRAWING NUMBER M-03B

SEE SAN DIEGO REGIONAL STANDARD DRAWING:

SC-01 (SEWER CLEANOUT)

Revision	By	Apprvd	Date	CITY OF VISTA STANDARD DRAWING	
New	SJ	GM	12/27/12		
				STANDARD SEWER DEAD END CLEANOUT	CITY ENGINEER, DATE RCE 55075
					DRAWING NUMBER: SWR-08

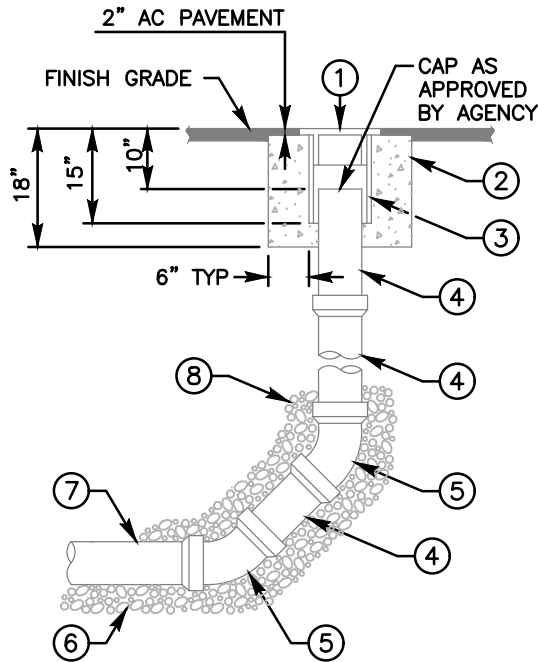

TYPE A
MAINS FOR 6" AND 8"

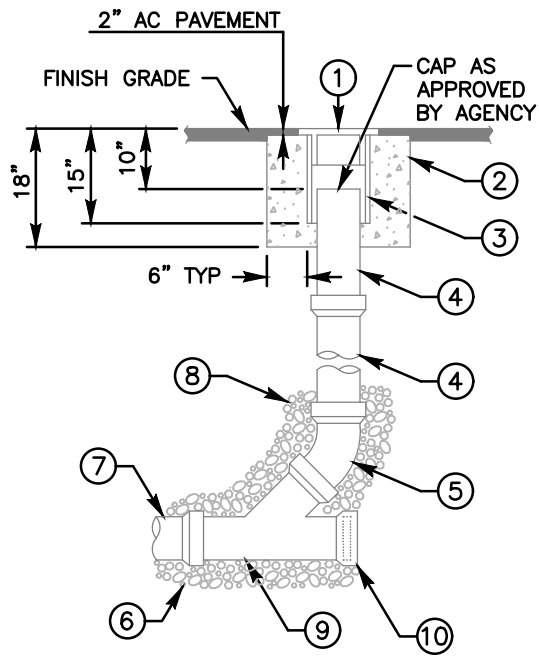

TYPE B
SEWER LATERAL
CLEANOUT

NOTES:

- 1) REFER TO AGENCY SPECIFICATIONS WHERE APPLICABLE
- 2) CLEANOUTS TO BE INSTALLED AT THE END OF MAINS WHERE INDICATED ON THE PLANS
- 3) CLEANOUT PIPE TO BE SAME SIZE AND MATERIAL AS SEWER MAIN UP TO 8"
- 4) BACKFILL TO TOP OF 45° BEND WITH 3/4" CRUSHED ROCK
- 5) MATERIALS SHALL BE SELECTED FROM THE AGENCY'S APPROVED MATERIALS LIST

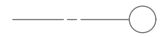

LEGEND ON PLANS

ITEM NO	SIZE AND DESCRIPTION	ITEM NO	SIZE AND DESCRIPTION
①	12" CI CLEANOUT BOX COVER MARKED 'SEWER' AND AGENCY NAME AS REQUIRED	⑤	45° ELBOW
②	CONCRETE RING	⑥	3/4" CRUSHED ROCK PIPE BEDDING
③	12" PVC, C-900 x 15" LONG (CLEANOUT BOX)	⑦	SEWER MAIN
④	SIZE x REQUIRED LENGTH PVC PIPE	⑧	3/4" CRUSHED ROCK SEE NOTE 4
		⑨	STANDARD WYE BRANCH
		⑩	INSTALL PLUG AND CONCRETE LUG

Revision	By	Approved	Date	SAN DIEGO REGIONAL STANDARD DRAWING	SEWER CLEANOUT	RECOMMENDED BY THE SAN DIEGO REGIONAL STANDARDS COMMITTEE <i>Samsen Engeda</i> 03/24/2022 Chairperson R.C.E. 52241 Date
ORIGINAL		Kercheval	12/75			
Reviewed	BK	B. KNOLL	04/15			
Reviewed	BK	B. KNOLL	10/18			
Reviewed	RP	S. Engeda	03/22			
DRAWING NUMBER SC-01						

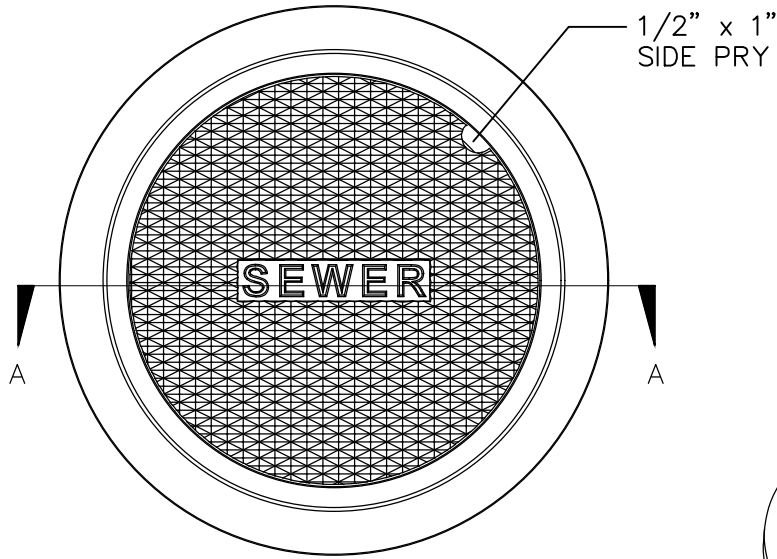

TOP VIEW

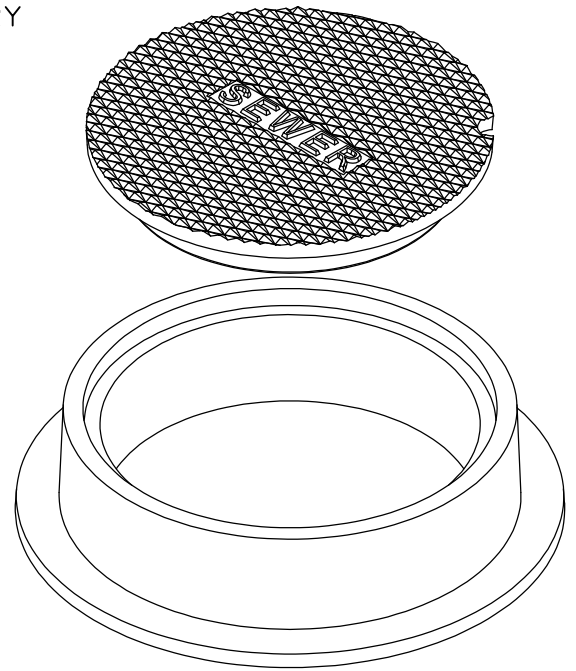

ISOMETRIC VIEW

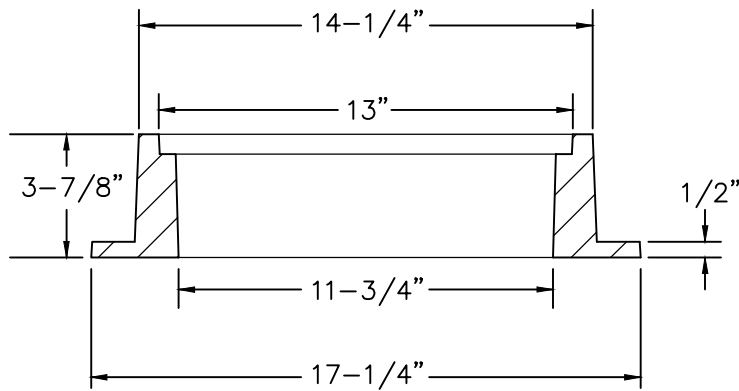
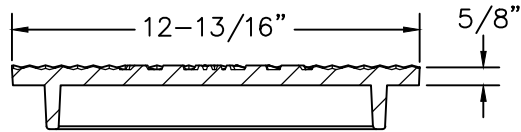

SECTION A-A

LEGEND

SCO



NOTES:

1. MATERIAL SHALL BE GRAY CAST IRON ASTM A48, CLASS 30B AND MADE IN U.S.A.
2. BEARING SURFACES SHALL BE MACHINED FOR CLOSE & QUIET FIT.
3. CASTINGS SHALL BE DIPPED IN BLACK BITUMINOUS PAINT FOR FINISH.
4. FRAME AND LID SHALL MEET HS-20 WHEEL LOAD REQUIREMENTS.
5. CAST SHALL BE BY SOUTH BAY FOUNDRY 1242 (OR APPROVED EQUAL).

Revision	By	Apprvd	Date
New	SJ	GM	12/27/12
Updated	EA	GM	04/04/13
Updated	SN	KK	05/23/23

CITY OF VISTA
STANDARD DRAWING

STANDARD 12" Ø SEWER
CLEANOUT FRAME AND LID

Signature

CITY ENGINEER, DATE
RCE 55075

DRAWING NUMBER: **SWR-09**

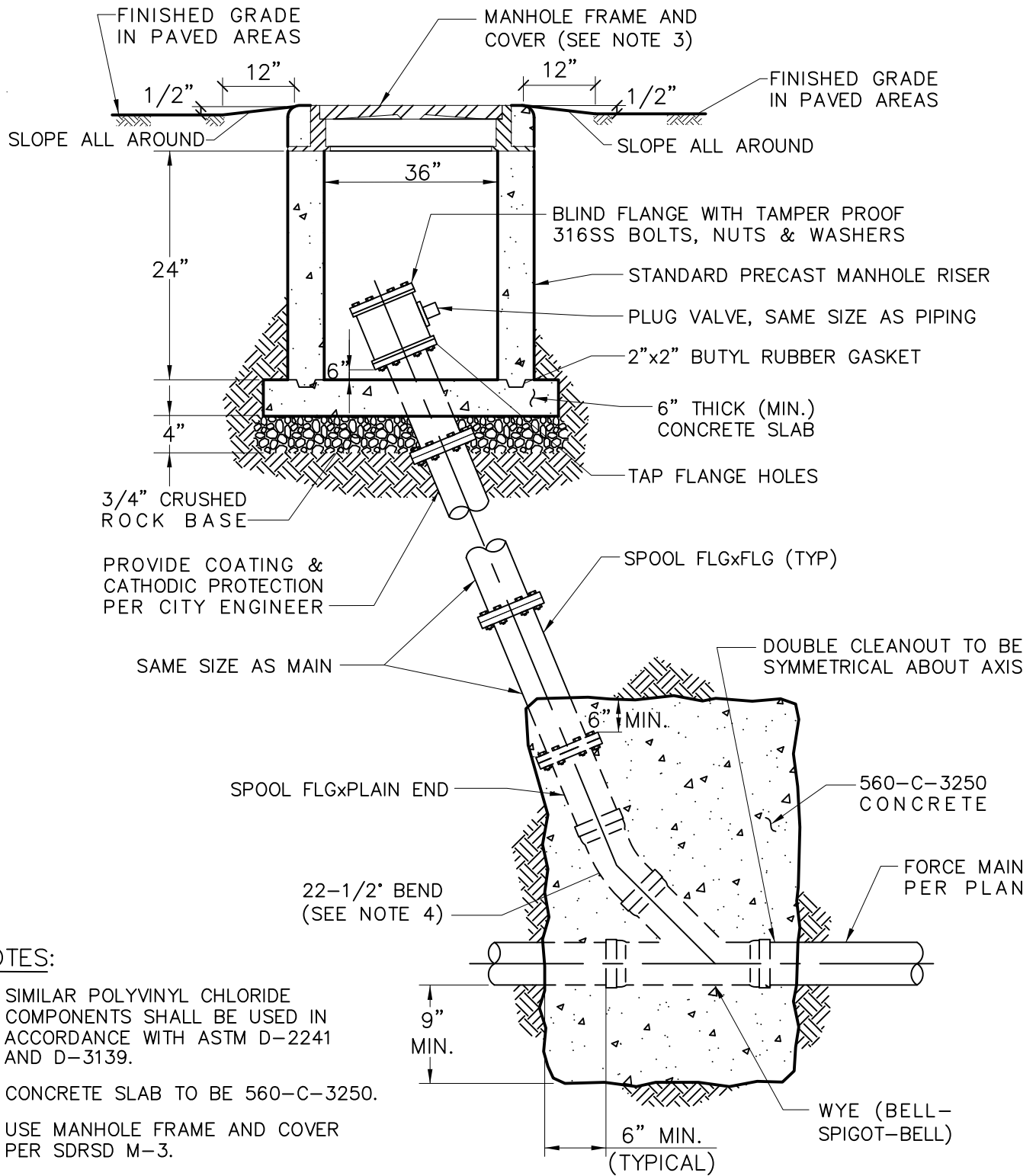

NOTES:

1. SIMILAR POLYVINYL CHLORIDE COMPONENTS SHALL BE USED IN ACCORDANCE WITH ASTM D-2241 AND D-3139.
2. CONCRETE SLAB TO BE 560-C-3250.
3. USE MANHOLE FRAME AND COVER PER SDRSD M-3.
4. MORE THAN ONE 22-1/2° BEND SHALL BE APPROVED BY CITY ENGINEER.
5. PIPE PRESSURE CLASS MINIMUM 200 PSI OR EQUAL TO FORCE MAIN PRESSURE CLASS WHICH EVER IS GREATER.

ELEVATION

C.O.

 LEGEND ON PLANS

Revision	By	Apprvd	Date
New	SJ	GM	12/27/12
Updated	GL	EA	05/07/14

CITY OF VISTA
STANDARD DRAWING

SEWER FORCE MAIN CLEANOUT

A. J. ...
CITY ENGINEER, DATE
RCE 55075

DRAWING NUMBER: **SWR-10**

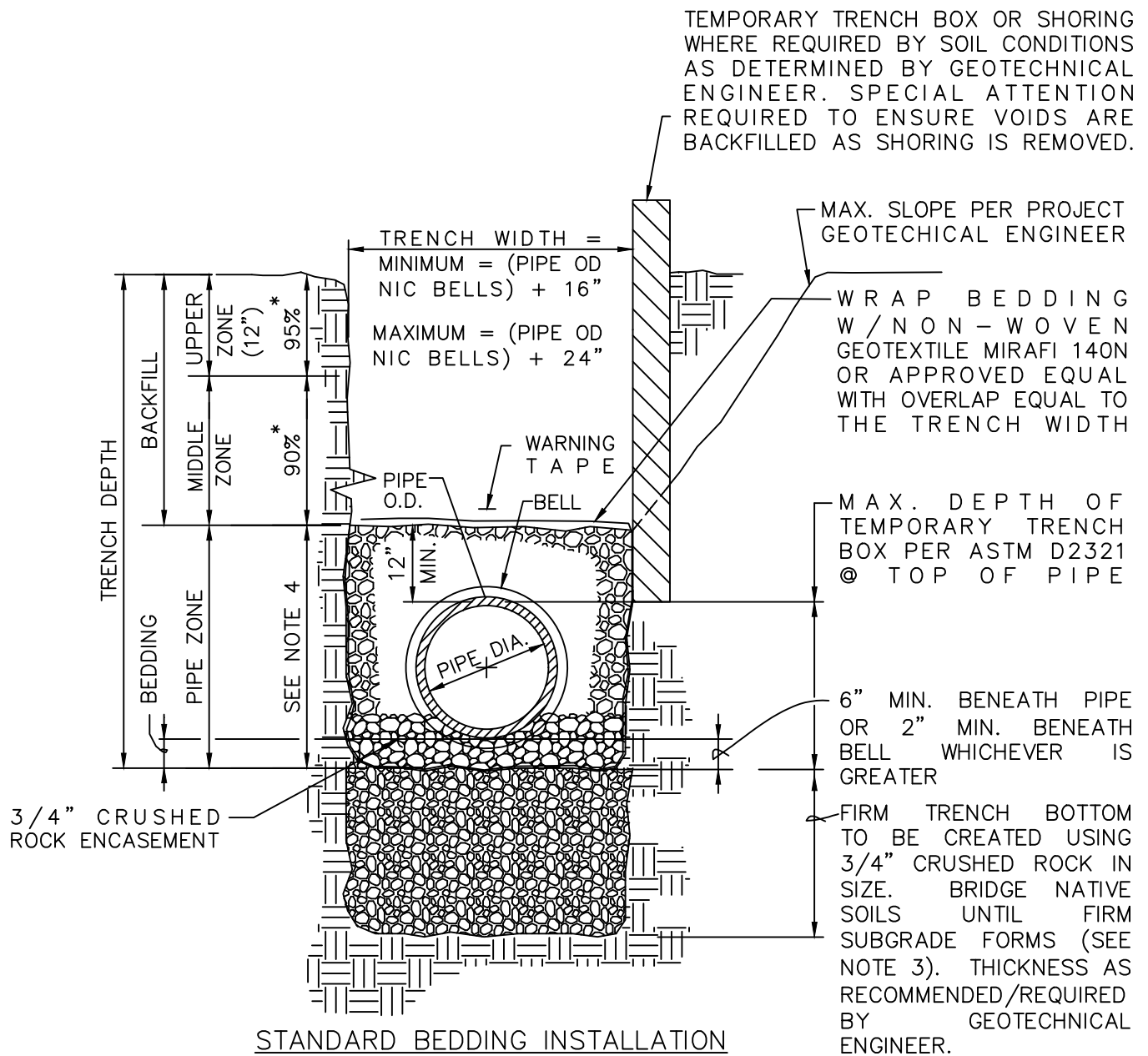

NOTES:

1. ALL PIPING SHALL BE INSTALLED IN ACCORDANCE W/ ASTM D2321 (STANDARD PRACTICE FOR UNDERGROUND INSTALLATION OF PIPE FOR SEWERS & OTHER GRAVITY-FLOW APPLICATIONS).
2. (*) INDICATES MINIMUM RELATIVE COMPACTION.
3. UNDISTURBED NATIVE SOIL IS ANTICIPATED TO BE 85% RELATIVE COMPACTION AT TRENCH BOTTOM, WHICH IS SUITABLE AS "FIRM TRENCH BOTTOM." IF THE TRENCH BOTTOM IS LESS THAN 85% RELATIVE COMPACTION, CONTRACTOR SHALL PLACE CRUSHED ROCK AS INDICATED BY TRENCH DETAIL.
4. PROVIDE COMPACTION EFFORT SUITABLE TO UNIFORMLY LOAD THE ENTIRE CIRCUMFERENCE OF THE PIPE.

Revision	By	Apprvd	Date	CITY OF VISTA STANDARD DRAWING	
New	SJ	GM	01/29/13	 CITY ENGINEER, DATE RCE 55075	
Updated	SN	KK	05/23/23		
				STANDARD SEWER PIPE ZONE AND TRENCH BACKFILL	

SEE CITY OF VISTA STANDARD DRAWINGS:

SRF-08A AND SRF-08B (TRENCH PAVING STANDARD TYPES)

Revision	By	Apprvd	Date	CITY OF VISTA STANDARD DRAWING	
New	SJ	GM	01/29/13		
				STANDARD PIPE TRENCH DETAIL IN EXISTING STREETS	CITY ENGINEER, DATE RCE 55075
					DRAWING NUMBER: SWR-12

SEE CITY OF VISTA STANDARD DRAWINGS:

SRF-11A AND SRF-11B
(TEMPORARY STEEL PLATE COVERS & NOTES)

AND

SAN DIEGO REGIONAL STANDARD DRAWING:

SP-03 (CONCRETE PROTECTION FOR SEWER PIPE)

Revision	By	Apprvd	Date	CITY OF VISTA STANDARD DRAWING	
New	SJ	GM	01/30/13		
				CONCRETE CROWN PROTECTION FOR EXISTING SEWER INLETS	CITY ENGINEER, DATE RCE 55075
					DRAWING NUMBER: SWR-13

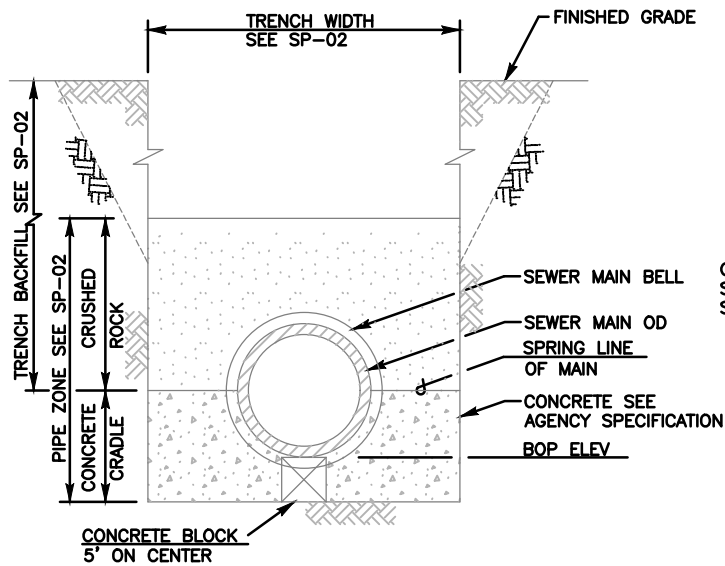

TRENCH SECTION
CONCRETE PIPE CRADLE

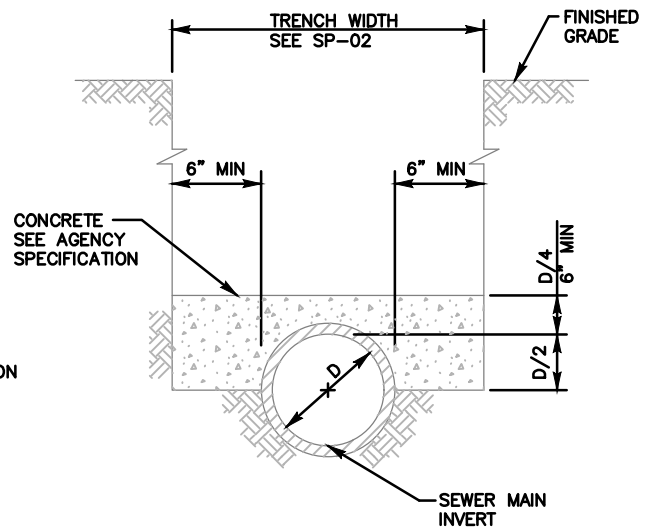

TRENCH SECTION
CONCRETE PROTECTION

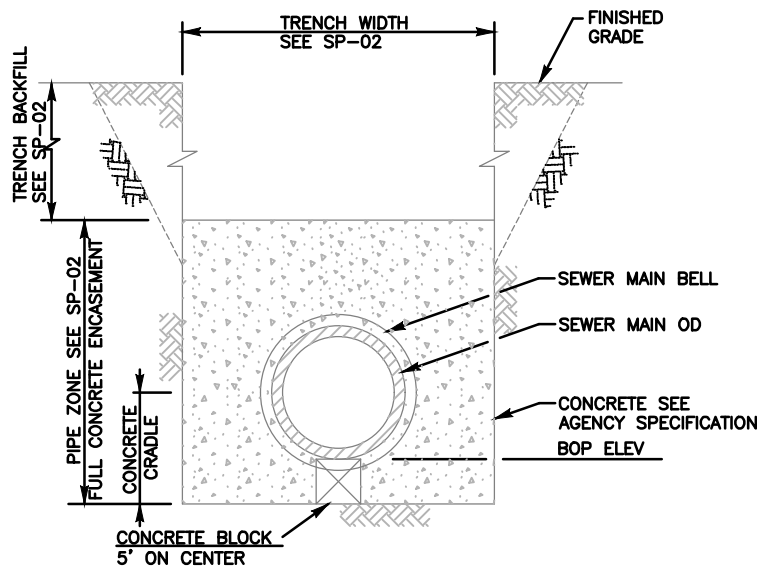

TRENCH SECTION
CONCRETE PIPE ENCASEMENT

NOTES:

- 1) REFER TO AGENCY SPECIFICATIONS FOR TRENCHING, BACKFILLING AND COMPACTING WHERE APPLICABLE
- 2) CONCRETE CRADLE SHALL BE USED WHEN THE TRENCH WIDTH AT THE UPPER LIMIT OF THE PIPE ZONE EXCEEDS THE MAX WIDTH SPECIFIED ON SP-02 AND OR DIRECTED BY AGENCY'S ENGINEER
- 3) FOR PIPE BEDDING AND TRENCH BACKFILL SEE SP-02



LEGEND ON PLANS

Revision	By	Approved	Date
ORIGINAL		Kercheval	12/75
Reviewed	BK	B. KNOLL	04/15
Reviewed	BK	B. KNOLL	10/18
Reviewed	RP	S. Engeda	03/22

SAN DIEGO REGIONAL STANDARD DRAWING

**CONCRETE PROTECTION FOR
SEWER PIPE**

RECOMMENDED BY THE SAN DIEGO
REGIONAL STANDARDS COMMITTEE

Susan Engeda 03/24/2022
Chairperson R.C.E. 52241 Date

DRAWING NUMBER **SP-03**

SEE SAN DIEGO REGIONAL STANDARD DRAWING:

SP-09

(PIPE SUPPORT FOR UNDERCUT SEWER
MAINS OR SEWER LATERALS)

Revision	By	Apprvd	Date	CITY OF VISTA STANDARD DRAWING	
New	SJ	GM	01/30/13		
				CONCRETE SUPPORT FOR UNDERCUT SEWER PIPE	CITY ENGINEER, DATE RCE 55075
					DRAWING NUMBER: SWR-14

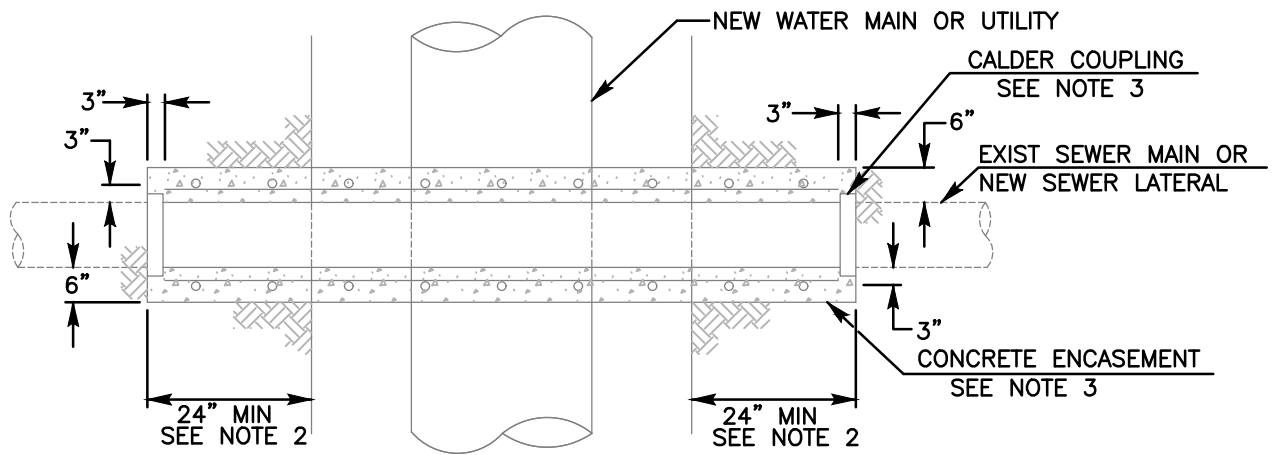

PLAN

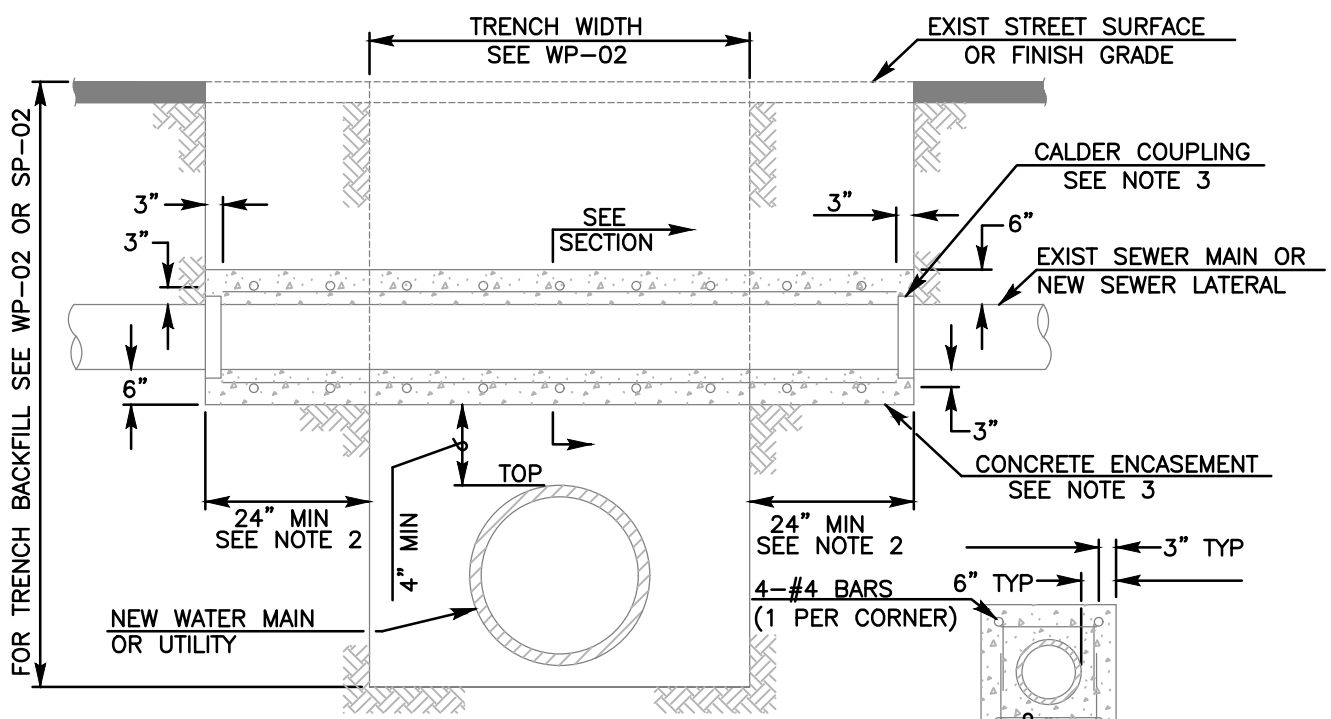

ELEVATION



ENCASEMENT SECTION

NOTES:

- 1) REFER TO AGENCY SPECIFICATIONS FOR PROTECTION OF EXISTING FACILITIES
- 2) ENCASEMENT SHALL EXTEND TO FIRST JOINT BEYOND BOTH SIDES OF TRENCH (24" MIN, 48" MAX OF SUITABLE NATIVE SUPPORT BEYOND EDGE OF TRENCH).
- 3) CONCRETE ENCASEMENT REQUIRED FOR SEWER MAINS ONLY. CALDER COUPLINGS REQUIRED FOR SEWER LATERALS ONLY. SEWER LATERALS TO BE REPLACED WITH SCH. 80 PVC WITH NO INTERMEDIATE JOINTS.
- 4) FOR PIPE BEDDING AND TRENCH BACKFILL SEE WP-02 OR SP-02.



LEGEND ON PLANS

Revision	By	Approved	Date
ORIGINAL		J. Tomasulo	03/05
Reviewed	BK	B. KNOLL	04/15
Reviewed	BK	B. KNOLL	10/18
Reviewed	RP	S. Engeda	03/22

SAN DIEGO REGIONAL STANDARD DRAWING

**PIPE SUPPORT FOR UNDERCUT
SEWER MAINS OR SEWER LATERALS**

RECOMMENDED BY THE SAN DIEGO REGIONAL STANDARDS COMMITTEE

Samantha Engeda 03/24/2022
Chairperson R.C.E. 52241 Date

DRAWING NUMBER **SP-09**

SEE SAN DIEGO REGIONAL STANDARD DRAWING:

SP-03 (CONCRETE PROTECTION FOR SEWER PIPE)

Revision	By	Apprvd	Date	CITY OF VISTA STANDARD DRAWING	
New	SJ	GM	01/30/13		
				CONCRETE ENCASEMENT	CITY ENGINEER, DATE RCE 55075
					DRAWING NUMBER: SWR-15

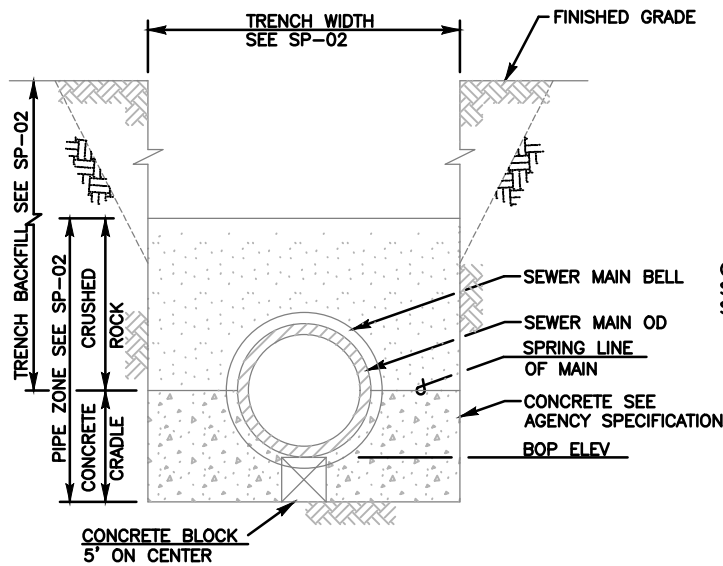

TRENCH SECTION
CONCRETE PIPE CRADLE

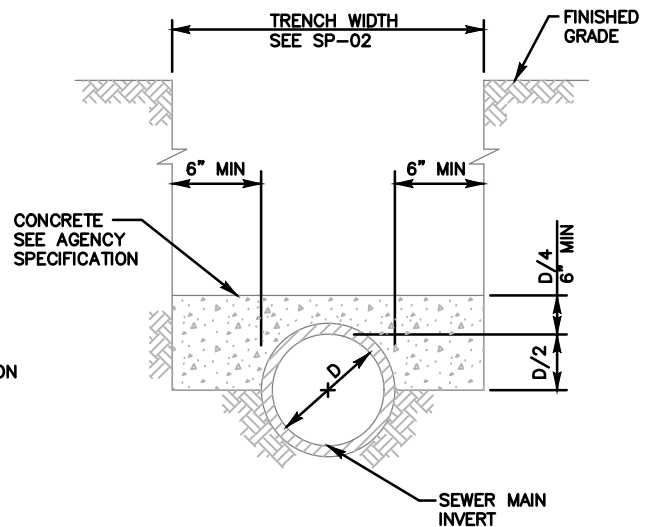

TRENCH SECTION
CONCRETE PROTECTION

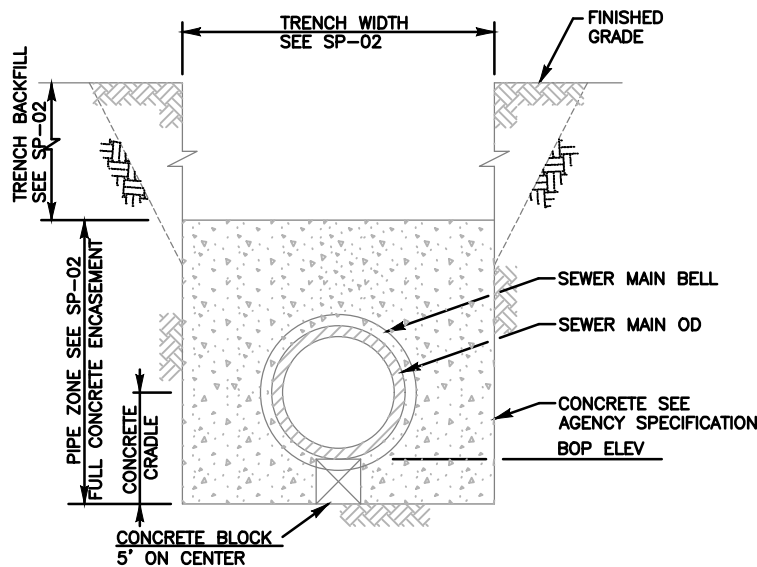

TRENCH SECTION
CONCRETE PIPE ENCASEMENT

NOTES:

- 1) REFER TO AGENCY SPECIFICATIONS FOR TRENCHING, BACKFILLING AND COMPACTING WHERE APPLICABLE
- 2) CONCRETE CRADLE SHALL BE USED WHEN THE TRENCH WIDTH AT THE UPPER LIMIT OF THE PIPE ZONE EXCEEDS THE MAX WIDTH SPECIFIED ON SP-02 AND OR DIRECTED BY AGENCY'S ENGINEER
- 3) FOR PIPE BEDDING AND TRENCH BACKFILL SEE SP-02



LEGEND ON PLANS

Revision	By	Approved	Date
ORIGINAL		Kercheval	12/75
Reviewed	BK	B. KNOLL	04/15
Reviewed	BK	B. KNOLL	10/18
Reviewed	RP	S. Engeda	03/22

SAN DIEGO REGIONAL STANDARD DRAWING

**CONCRETE PROTECTION FOR
SEWER PIPE**

RECOMMENDED BY THE SAN DIEGO
REGIONAL STANDARDS COMMITTEE

Susan Engeda 03/24/2022
Chairperson R.C.E. 52241 Date

DRAWING NUMBER **SP-03**

SEE SAN DIEGO REGIONAL STANDARD DRAWINGS:

SP-05 (SLOPE PROTECTION INSTALLATIONS)

AND

SP-07 (CUT-OFF WALL INSTALLATIONS IN TRAVELED AREAS)

Revision	By	Apprvd	Date	CITY OF VISTA STANDARD DRAWING	
New	SJ	GM	01/30/13		
					DRAWING NUMBER: SWR-16

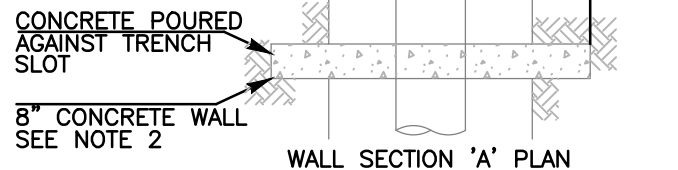
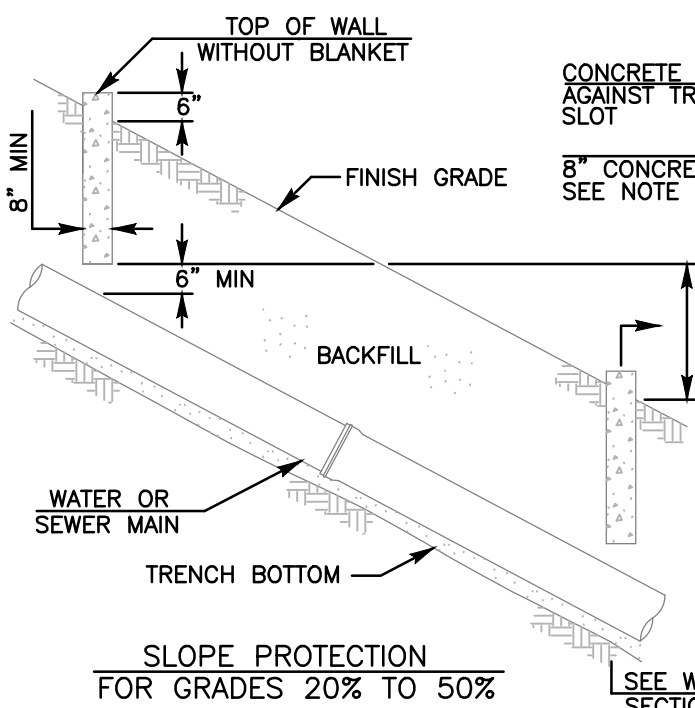
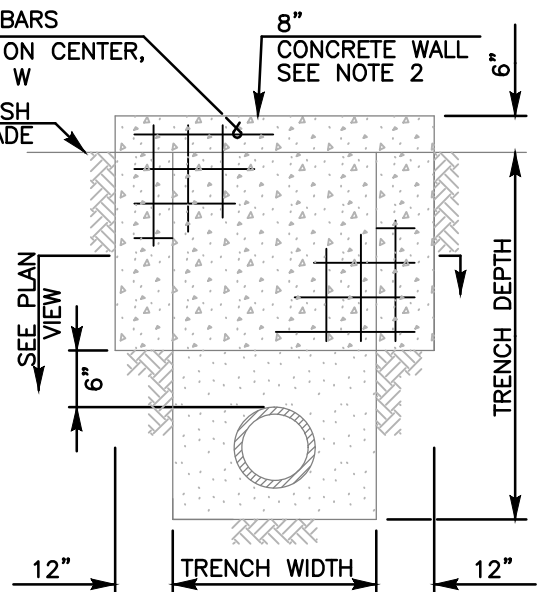
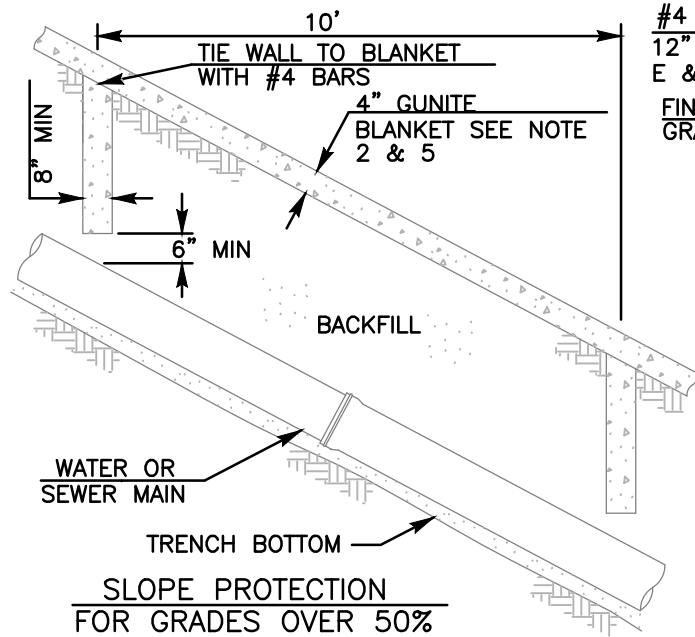

SLOPE PROTECTION FOR GRADES 20% TO 50%

WALL SECTION 'A' ELEVATION

WALL SECTION 'A' PLAN

NOTES:

- 1) REFER TO AGENCY SPECIFICATIONS WHERE APPLICABLE
- 2) THE DETAILS SHOWN REPRESENT THE MINIMUM REQUIRED. THE ENGINEER OF WORK IS REQUIRED TO PROVIDE A SUBMITTAL TO THE AGENCY OF JURISDICTION FOR REVIEW AND APPROVAL BY THE AGENCY'S ENGINEER PRIOR TO INSTALLATION
- 3) WALLS SHALL BE REINFORCED CONCRETE OR 8" x 8" x 16" CONCRETE BLOCK, REINFORCED AND ALL CORES FILLED WITH GROUT SEE SPECIFICATIONS
- 4) FOR GRADES OVER 50%, SLOPE PROTECTION SHALL ALSO INCLUDE AC PAVING, CONCRETE SLAB OR GUNITITE BLANKET PLACED OVER THE PIPELINE ALIGNMENT
- 5) 4" GUNITITE BLANKET WITH 6" SQUARE x 10 GAGE WIRE FABRIC AT THE ENGINEERS DISCRETION

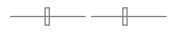

LEGEND ON PLANS

Revision	By	Approved	Date
ORIGINAL		J. Tomasulo	03/05
Reviewed	BK	B. KNOLL	04/15
Reviewed	BK	B. KNOLL	10/18
Reviewed	RP	S. Engeda	03/22

SAN DIEGO REGIONAL STANDARD DRAWING

SLOPE PROTECTION INSTALLATIONS

RECOMMENDED BY THE SAN DIEGO REGIONAL STANDARDS COMMITTEE

Somvir Engeda 03/24/2022
Chairperson R.C.E. 52241 Date

DRAWING NUMBER SP-05

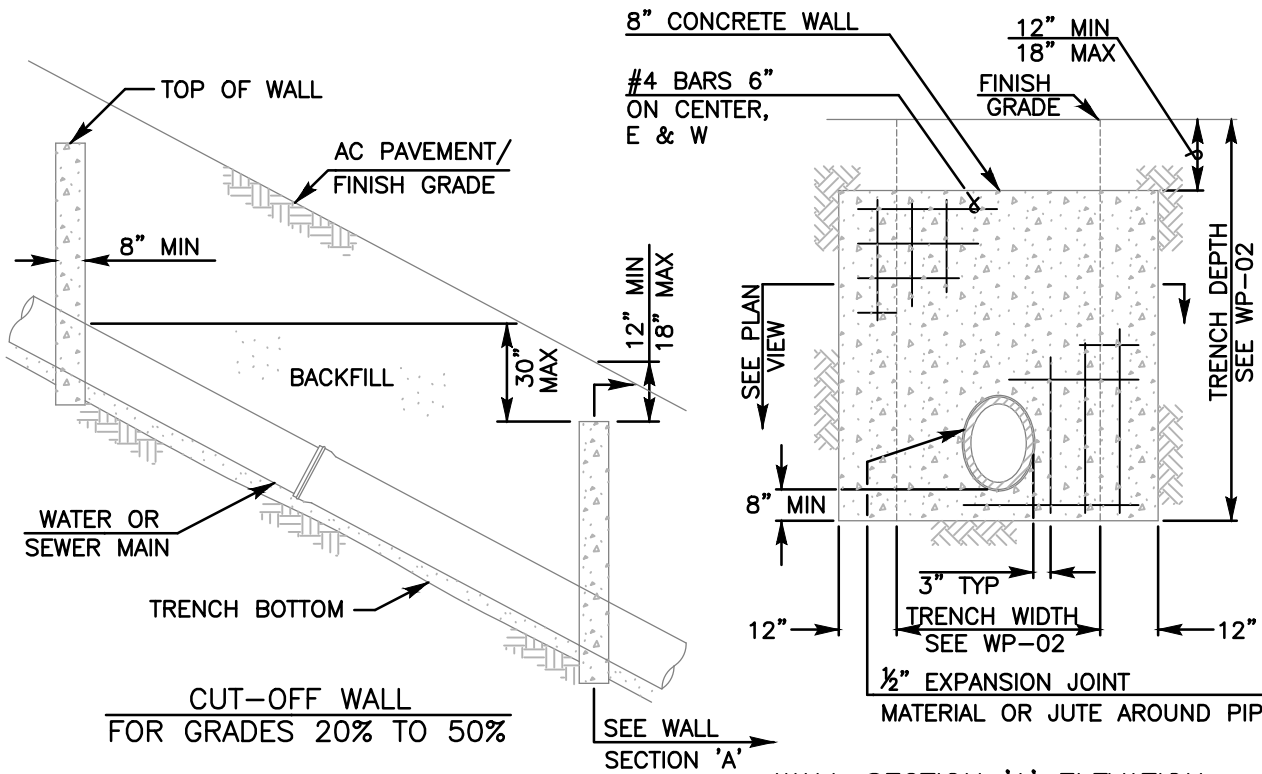

WALL SECTION 'A' ELEVATION

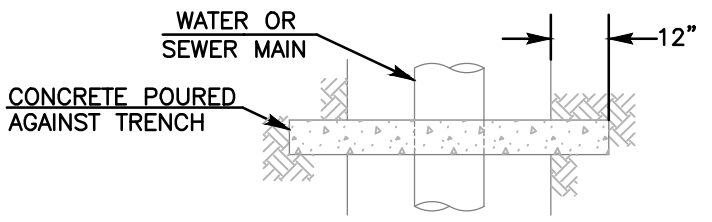

WALL SECTION 'A' PLAN

NOTES:

- 1) REFER TO AGENCY SPECIFICATIONS WHERE APPLICABLE
- 2) FOR USE AS TRENCH BACKFILL STABILIZATION IN TRAVELED AREAS
- 3) THE DETAILS SHOWN REPRESENT THE MINIMUM REQUIRED. THE ENGINEER OF WORK IS REQUIRED TO PROVIDE A SUBMITTAL TO THE AGENCY OF JURISDICTION FOR REVIEW AND APPROVAL BY THE AGENCY'S ENGINEER PRIOR TO INSTALLATION
- 4) WALLS SHALL BE REINFORCED CONCRETE OR 8" x 8" x 16" CONCRETE BLOCK, REINFORCED AND ALL CORES FILLED WITH GROUT SEE SPECIFICATIONS (HOR. 2-#4@32", VERT. 1-#4@8")
- 5) FOR GRADES OVER 50% SEE WP-05/SP-05



LEGEND ON PLANS

Revision				SAN DIEGO REGIONAL STANDARD DRAWING		RECOMMENDED BY THE SAN DIEGO REGIONAL STANDARDS COMMITTEE	
ORIGINAL		J. Tomasulo	03/05	CUT-OFF WALL INSTALLATION IN TRAVELED AREAS		03/24/2022 Chairperson R.C.E. 52241 Date	
Note 4	BK	B. KNOLL	04/15				
Reviewed	BK	B. KNOLL	10/18				
Reviewed	RP	S. Engeda	03/22				
				DRAWING NUMBER		SP-07	

SEE SAN DIEGO REGIONAL STANDARD DRAWINGS:

SS-01 (4" AND 6" SEWER LATERAL INSTALLATION)

AND

SS-03 (SEWER LATERAL NOTES AND DETAIL)

NOTE: SEWER LATERAL CONNECTIONS TO MAINS WITH SPIRAL WOUND LINERS REQUIRE SPECIAL ATTENTION TO ENSURE LINING SYSTEM IS NOT DAMAGED, AND SHALL UTILIZE INSERTA-TEE (OR EQUIVALENT) CONNECTION TO SEAL SPIRAL WOUND LINER. TO PREVENT SLIPPAGE OF LINER, CUT-IN WYES ARE NOT PERMITTED.

Revision	By	Apprvd	Date	CITY OF VISTA STANDARD DRAWING	
New	SJ	GM	01/30/13		
Updated	SN	KK	05/23/23	SEWER LATERAL HOUSE CONNECTION	CITY ENGINEER, DATE RCE 55075
					DRAWING NUMBER: SWR-17

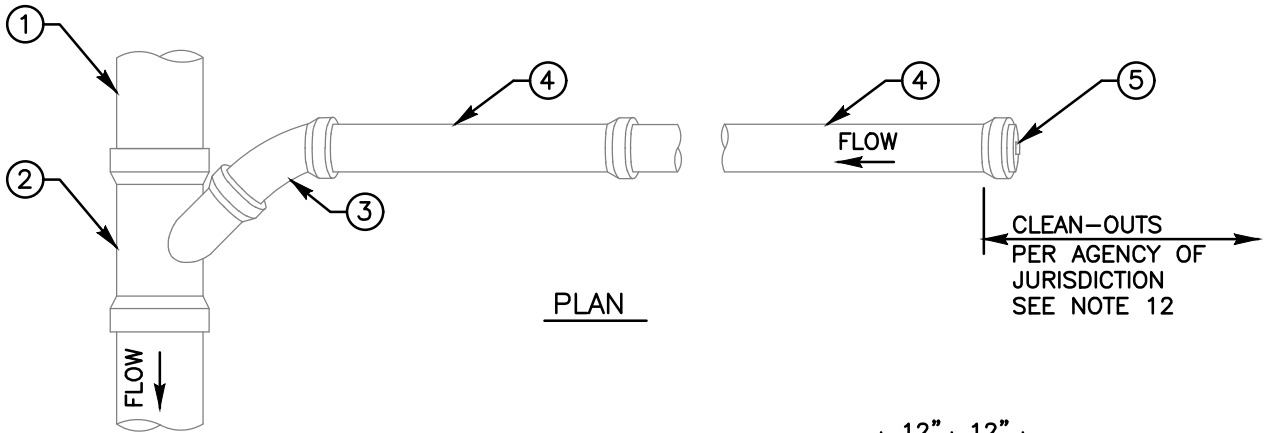

PLAN

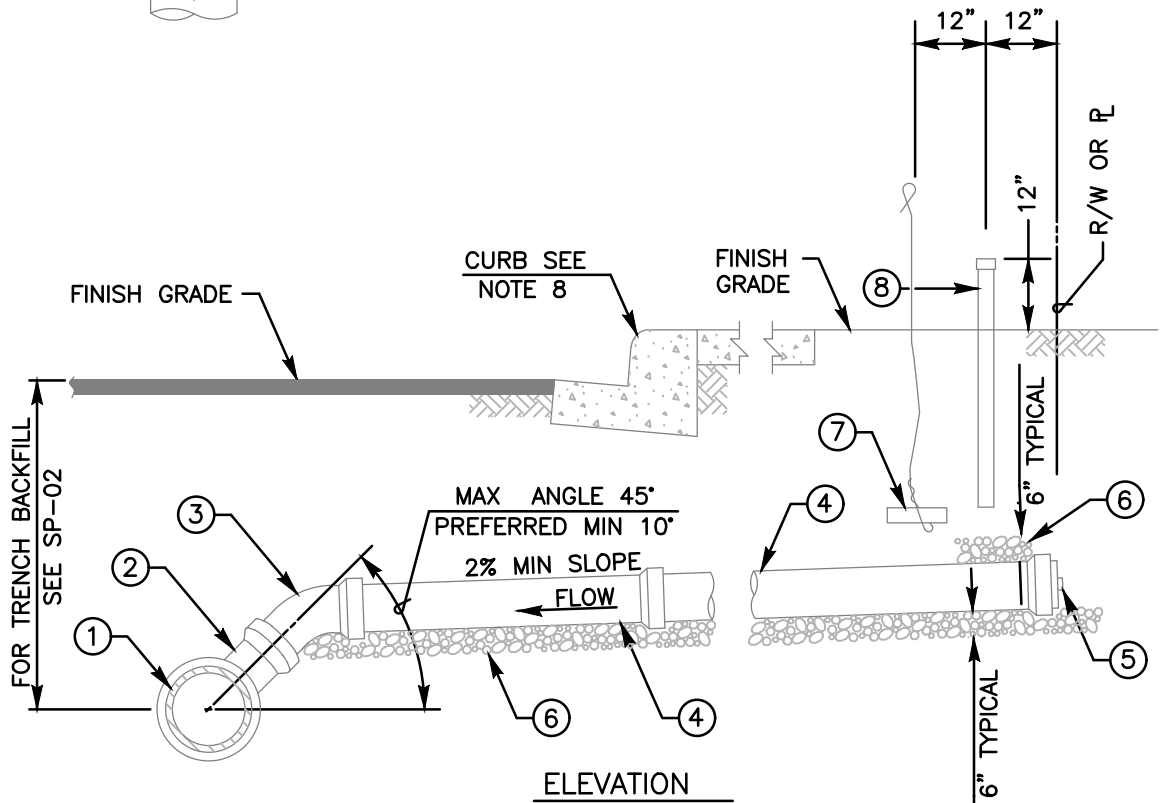

ELEVATION

(INDICATE SIZE)



LEGEND ON PLANS

FOR SEWER LATERAL NOTES SEE DETAIL SS-03

ITEM NO	SIZE AND DESCRIPTION	ITEM NO	SIZE AND DESCRIPTION
①	SEWER MAIN	⑤	PLUG OR CAP
②	45° WYE	⑥	3/4" MAXIMUM CRUSHED ROCK
③	45° ELBOW	⑦	#9 WIRE ATTACHED TO A BRICK
④	PIPE LATERAL SEE NOTE 3 & 5	⑧	4" PVC PIPE WITH GLUED CAP

Revision	By	Approved	Date
ORIGINAL		Kercheval	12/75
Reviewed	BK	B. KNOLL	04/15
Reviewed	BK	B. KNOLL	10/18
Reviewed	RP	S. Engeda	03/22

SAN DIEGO REGIONAL STANDARD DRAWING

**4" AND 6" SEWER LATERAL
INSTALLATION**

RECOMMENDED BY THE SAN DIEGO REGIONAL STANDARDS COMMITTEE

Samantha Engeda 03/24/2022
Chairperson R.C.E. 52241 Date

DRAWING NUMBER **SS-01**

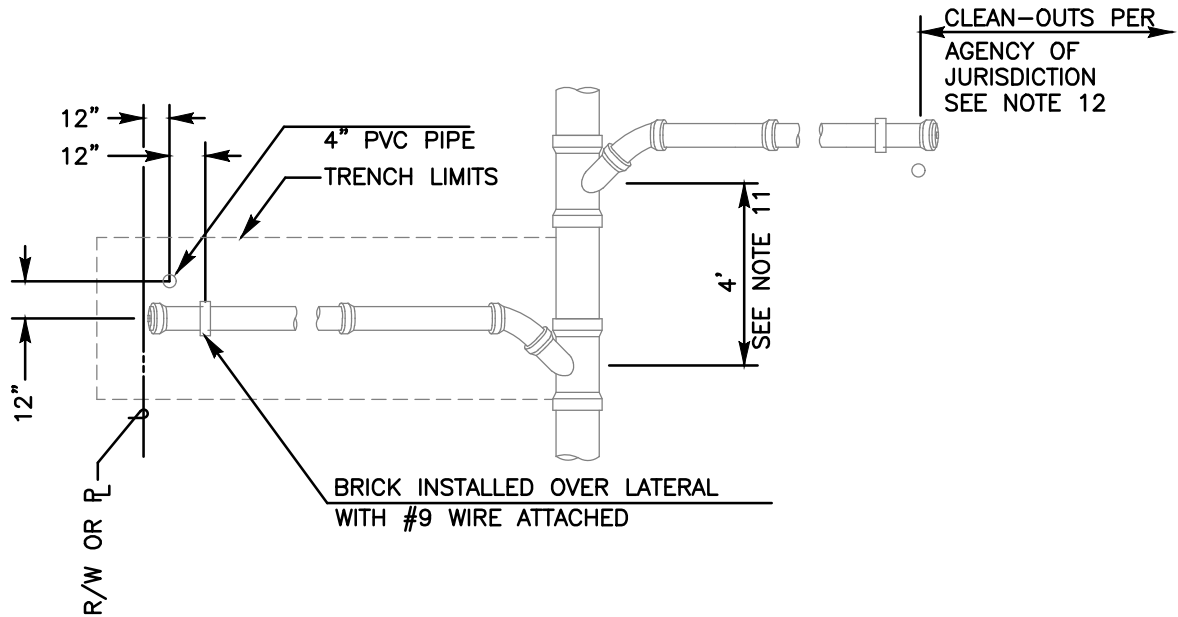

SEWER LATERAL DETAIL
SEE NOTE 10 BELOW

NOTES:

- 1) REFER TO AGENCY SPECIFICATIONS WHERE APPLICABLE
- 2) IN NO CASE SHALL LATERAL CONNECT DIRECTLY ON TOP OF SEWER MAIN
- 3) LATERAL SHALL BE INSTALLED TO PROPERTY LINE UNLESS SPECIFIED ON PLANS
- 4) MINIMUM 4' COVER ABOVE LATERAL AT PROPERTY LINE
- 5) LATERAL TO HAVE A MINIMUM SLOPE OF 2%
- 6) VERTICAL PIPE SHALL BE BRACED WHILE BACKFILLING TRENCH
- 7) INSTALL WARNING/IDENTIFICATION TAPE AS SHOWN ON SP-01
- 8) STAMP OR CHISEL A 2" HIGH "S" IN CURB FACE OVER LATERAL TO IDENTIFY SEWER LATERAL LOCATION
- 9) MATERIALS SHALL BE SELECTED FROM THE AGENCY'S APPROVED MATERIALS LIST
- 10) FOR SEWER LATERAL INSTALLATIONS SEE SS-01 AND SS-02
- 11) FOR SEWERS SPECIFIED AS PVC PIPE, A MINIMUM 3' SECTION OF PIPE IS REQUIRED BETWEEN FITTINGS
- 12) SEWER CLEAN-OUT SEE SC-01 TYPE B AS REQUIRED BY AGENCY OF JURISDICTION

(INDICATE SIZE)

 LEGEND ON PLANS

Revision	By	Approved	Date	SAN DIEGO REGIONAL STANDARD DRAWING		RECOMMENDED BY THE SAN DIEGO REGIONAL STANDARDS COMMITTEE
ORIGINAL		Kercheval	12/75	SEWER LATERAL NOTES AND DETAIL		 03/24/2022 Chairperson R.C.E. 52241 Date
Delete Metric	MR	B. KNOLL	03/11			
Reviewed	BK	B. KNOLL	10/18			
Reviewed	RP	S. Engeda	03/22			
				DRAWING NUMBER		SS-03

SEE SAN DIEGO REGIONAL STANDARD DRAWINGS:
SS-02 (4" AND 6" DEEP-CUT SEWER LATERAL INSTALLATION)
 AND
SS-03 (SEWER LATERAL NOTES AND DETAIL)

NOTE: SEWER LATERAL CONNECTIONS TO MAINS WITH SPIRAL WOUND LINERS REQUIRE SPECIAL ATTENTION TO ENSURE LINING SYSTEM IS NOT DAMAGED, AND SHALL UTILIZE INSERTA-TEE (OR EQUIVALENT) CONNECTION TO SEAL SPIRAL WOUND LINER. TO PREVENT SLIPPAGE OF LINER, CUT-IN WYES ARE NOT PERMITTED.

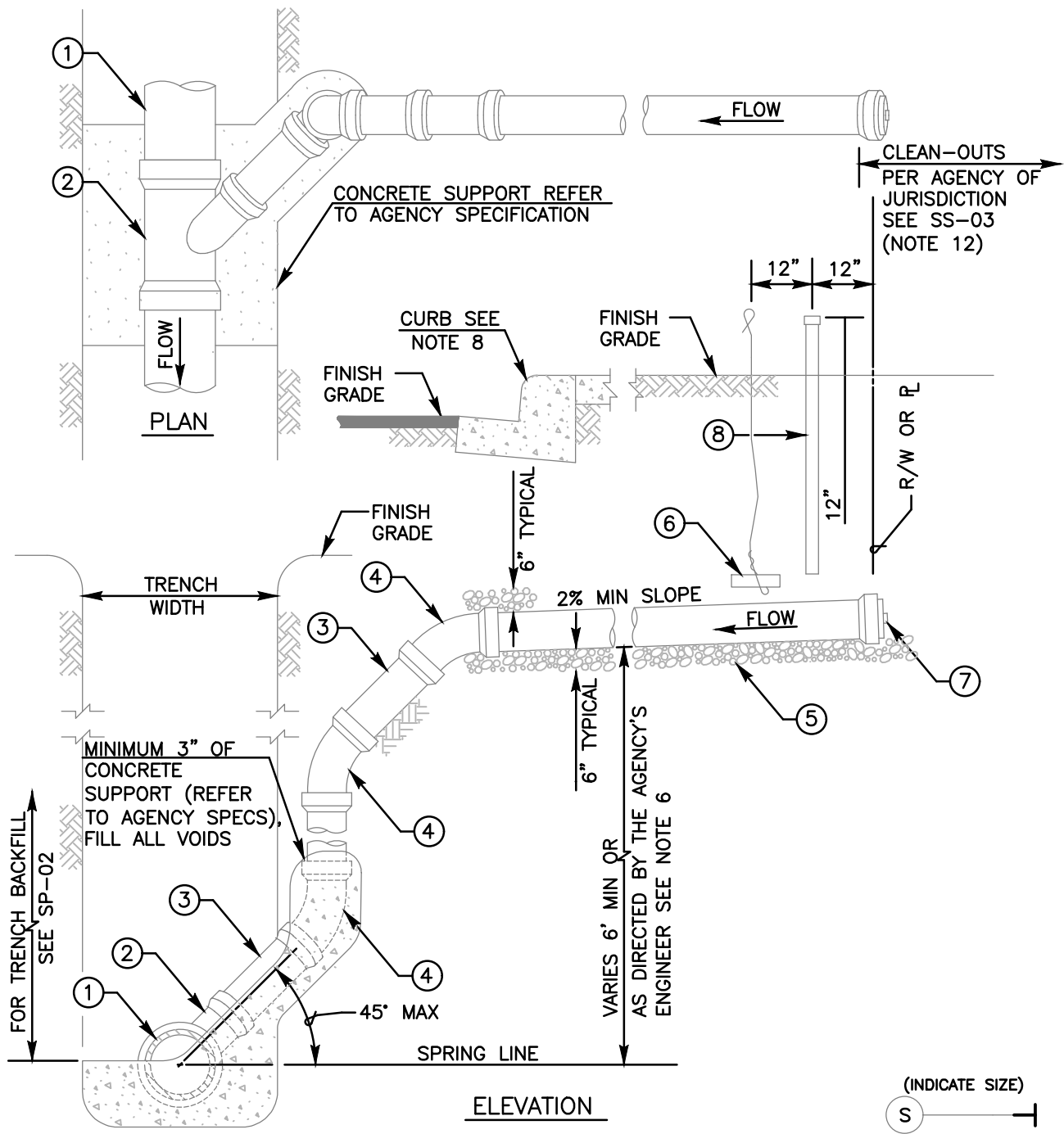
Revision	By	Apprvd	Date	CITY OF VISTA STANDARD DRAWING	
New	SJ	GM	01/30/13		
Updated	SN	KK	05/23/23	DRAWING NUMBER: SWR-18	



FOR SEWER LATERAL NOTES SEE DETAIL SS-03

(INDICATE SIZE)
 S ———— |
 LEGEND ON PLANS

ITEM NO	SIZE AND DESCRIPTION	ITEM NO	SIZE AND DESCRIPTION
①	SEWER MAIN	⑤	3/4" MAXIMUM CRUSHED ROCK
②	45° WYE	⑥	#9 WIRE ATTACHED TO A BRICK
③	PIPE	⑦	PLUG OR CAP
④	45° ELBOW	⑧	4" PVC PIPE WITH GLUED CAP

Revision	By	Approved	Date	SAN DIEGO REGIONAL STANDARD DRAWING 4" AND 6" DEEP-CUT SEWER LATERAL INSTALLATION	RECOMMENDED BY THE SAN DIEGO REGIONAL STANDARDS COMMITTEE	
ORIGINAL		Kercheval	12/75			
Delete Metric	MR	B. KNOLL	03/11			<i>Saman Engeda</i> 03/24/2022
Reviewed	BK	B. KNOLL	10/18			Chairperson R.C.E. 52241 Date
Reviewed	RP	S. Engeda	03/22			DRAWING NUMBER SS-02

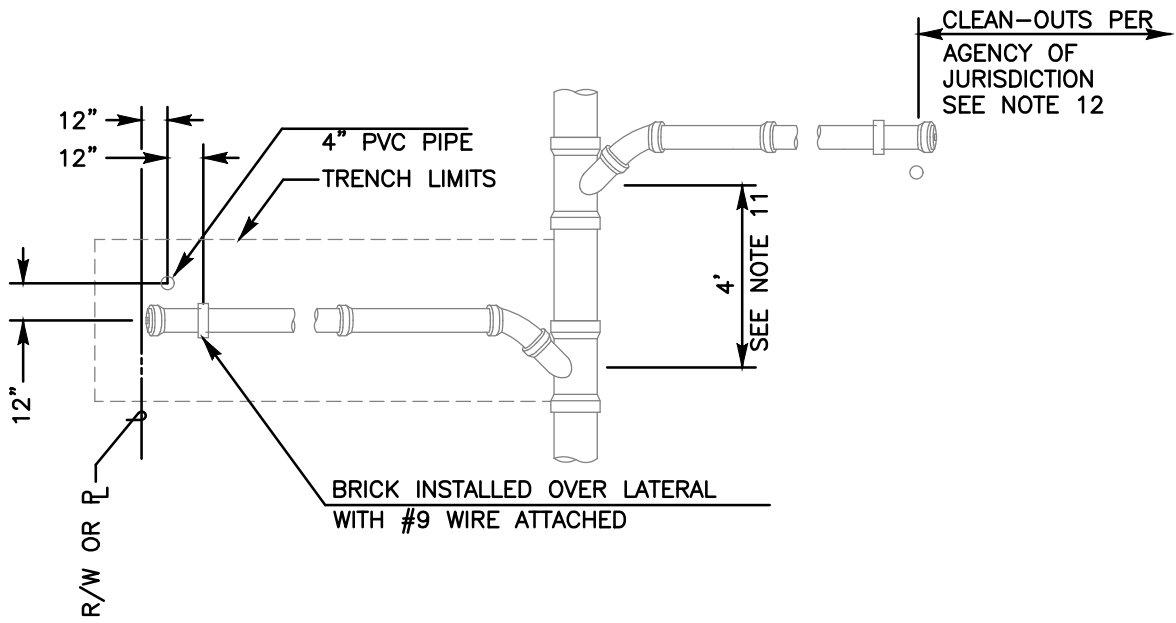

SEWER LATERAL DETAIL
SEE NOTE 10 BELOW

NOTES:

- 1) REFER TO AGENCY SPECIFICATIONS WHERE APPLICABLE
- 2) IN NO CASE SHALL LATERAL CONNECT DIRECTLY ON TOP OF SEWER MAIN
- 3) LATERAL SHALL BE INSTALLED TO PROPERTY LINE UNLESS SPECIFIED ON PLANS
- 4) MINIMUM 4' COVER ABOVE LATERAL AT PROPERTY LINE
- 5) LATERAL TO HAVE A MINIMUM SLOPE OF 2%
- 6) VERTICAL PIPE SHALL BE BRACED WHILE BACKFILLING TRENCH
- 7) INSTALL WARNING/IDENTIFICATION TAPE AS SHOWN ON SP-01
- 8) STAMP OR CHISEL A 2" HIGH "S" IN CURB FACE OVER LATERAL TO IDENTIFY SEWER LATERAL LOCATION
- 9) MATERIALS SHALL BE SELECTED FROM THE AGENCY'S APPROVED MATERIALS LIST
- 10) FOR SEWER LATERAL INSTALLATIONS SEE SS-01 AND SS-02
- 11) FOR SEWERS SPECIFIED AS PVC PIPE, A MINIMUM 3' SECTION OF PIPE IS REQUIRED BETWEEN FITTINGS
- 12) SEWER CLEAN-OUT SEE SC-01 TYPE B AS REQUIRED BY AGENCY OF JURISDICTION

(INDICATE SIZE)

 LEGEND ON PLANS

Revision	By	Approved	Date	SAN DIEGO REGIONAL STANDARD DRAWING SEWER LATERAL NOTES AND DETAIL	RECOMMENDED BY THE SAN DIEGO REGIONAL STANDARDS COMMITTEE  03/24/2022 Chairperson R.C.E. 52241 Date
ORIGINAL		Kercheval	12/75		
Delete Metric	MR	B. KNOLL	03/11		
Reviewed	BK	B. KNOLL	10/18		
Reviewed	RP	S. Engeda	03/22		
				DRAWING NUMBER	SS-03

THIS SHEET
INTENTIONALLY LEFT BLANK

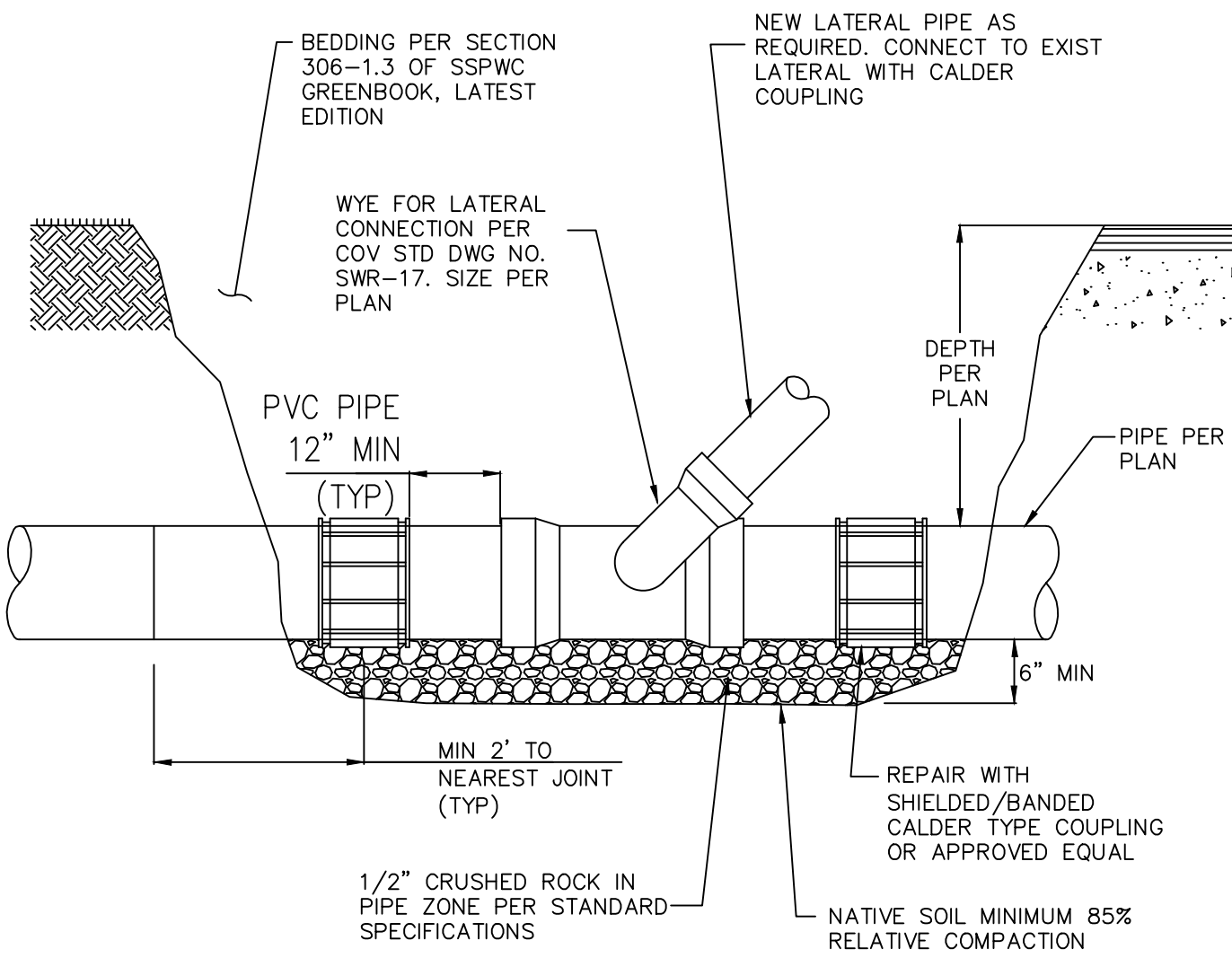
Revision	By	Apprvd	Date	CITY OF VISTA STANDARD DRAWING	
New	SJ	GM	01/30/13		
				STANDARD SEWER CUT-OFF WALL ANCHOR	CITY ENGINEER, DATE RCE 55075
					DRAWING NUMBER: SWR-19



- NOTES:
1. BYPASS OF SEWER FLOWS REQUIRES A SEPARATE SEWER BYPASS PLAN PER CITY OF VISTA "SEWER BYPASS PUMPING GUIDELINES AND REQUIREMENTS".
 2. TO PREVENT SLIPPAGE OF LINER, CUT-IN WYES ARE NOT PERMITTED ON MAINS WITH SPIRAL WOUND LINERS.

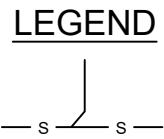

Revision	By	Apprvd	Date
New	GL	EA	05/07/14
Updated	SN	KK	05/23/23

CITY OF VISTA
STANDARD DRAWING

SEWER CUT-IN WYE CONNECTION

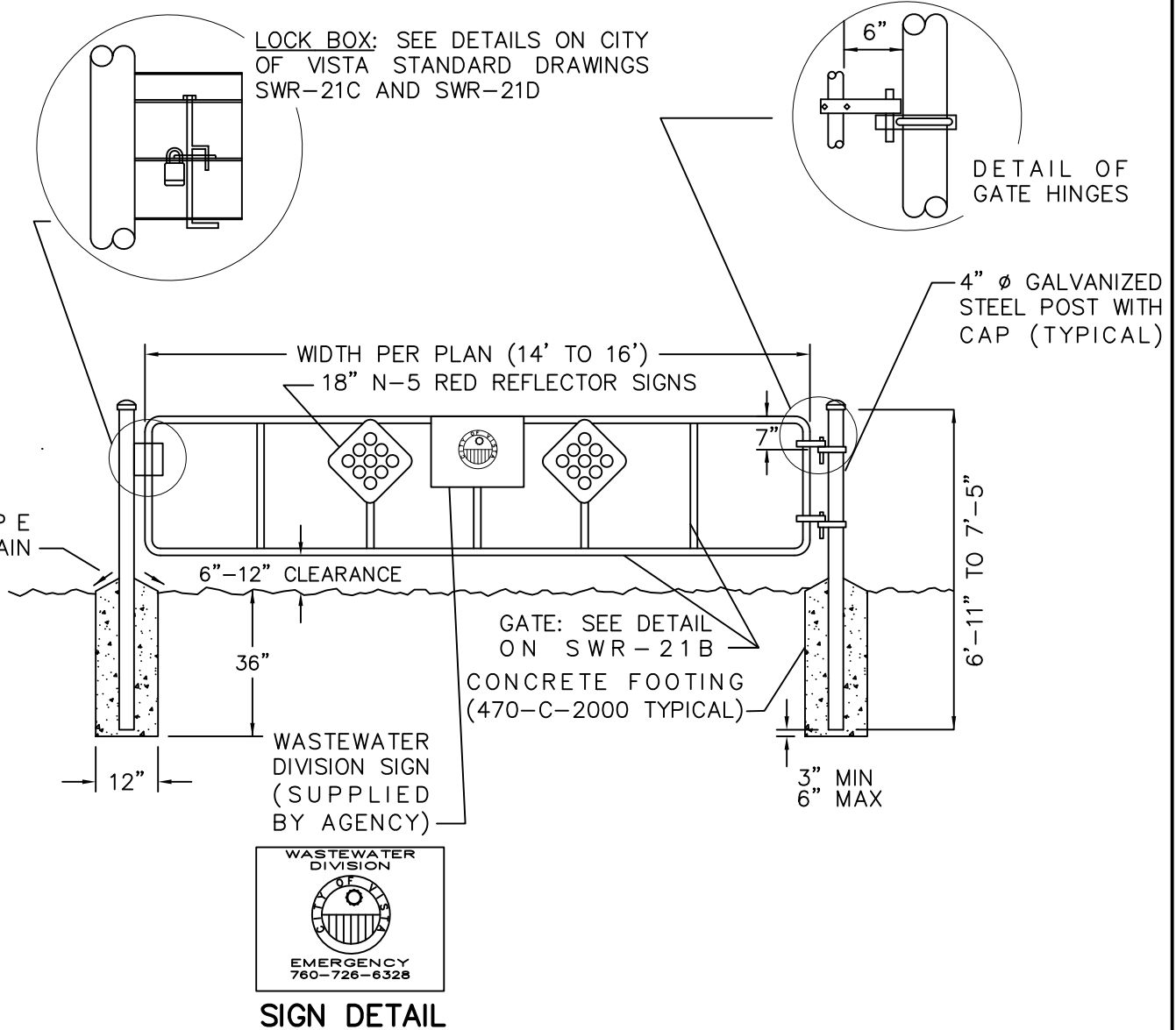

 CITY ENGINEER, DATE
 RCE 55075
 DRAWING NUMBER: **SWR-20**



NOTES:

1. GATE, LOCK BOX, HINGES AND POSTS ARE TO BE PAINTED PER PUBLIC WORKS DEPARTMENT REQUIREMENTS. POSTS IN FOOTINGS ARE TO BE SET PLUMB AND CONCRETE ALLOWED TO CURE FOR 48 HOURS PRIOR TO HANGING OF GATE.
2. POSTS ARE TO BE INSTALLED TO ACCOMODATE GATE, LOCK BOX AND HINGES. CONTRACTOR SHALL VERIFY INSIDE MEASUREMENT BETWEEN THE POSTS.
3. PROVIDE MINIMUM FIVE FOOT (5') WIDE OPENING FOR NON-VEHICULAR ACCESS.
4. ATTACH SIGNS TO GATE WITH SELF TAPPING SCREWS.

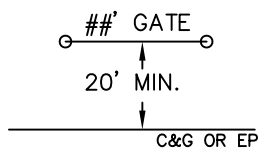
LEGEND



Revision	By	Apprvd	Date	CITY OF VISTA STANDARD DRAWING			
New		PN	09/11/00			 CITY ENGINEER, DATE RCE 55075	
Updated	TR	SS	04/24/08	SEWER EASEMENT GATE DRAWING NUMBER: SWR-21A			
Revised	SJ	GM	01/30/13				

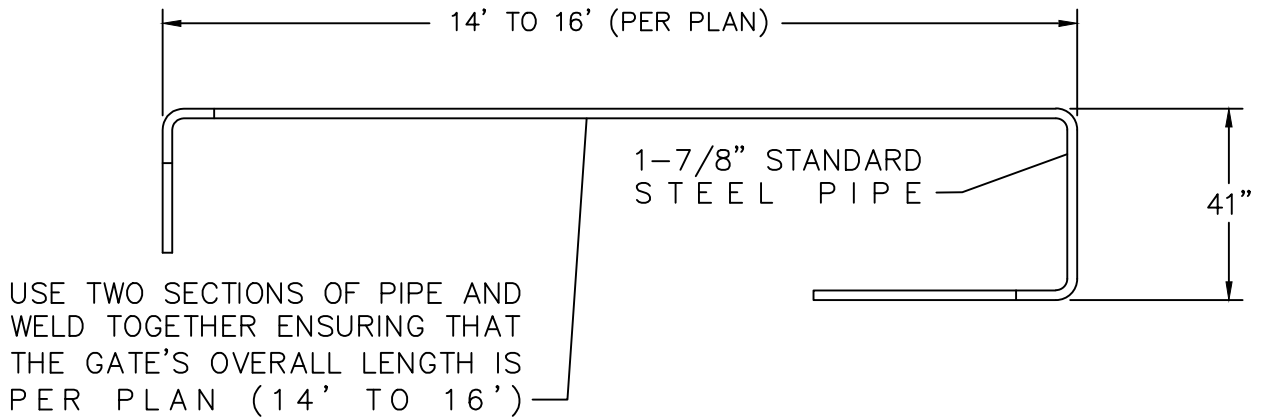
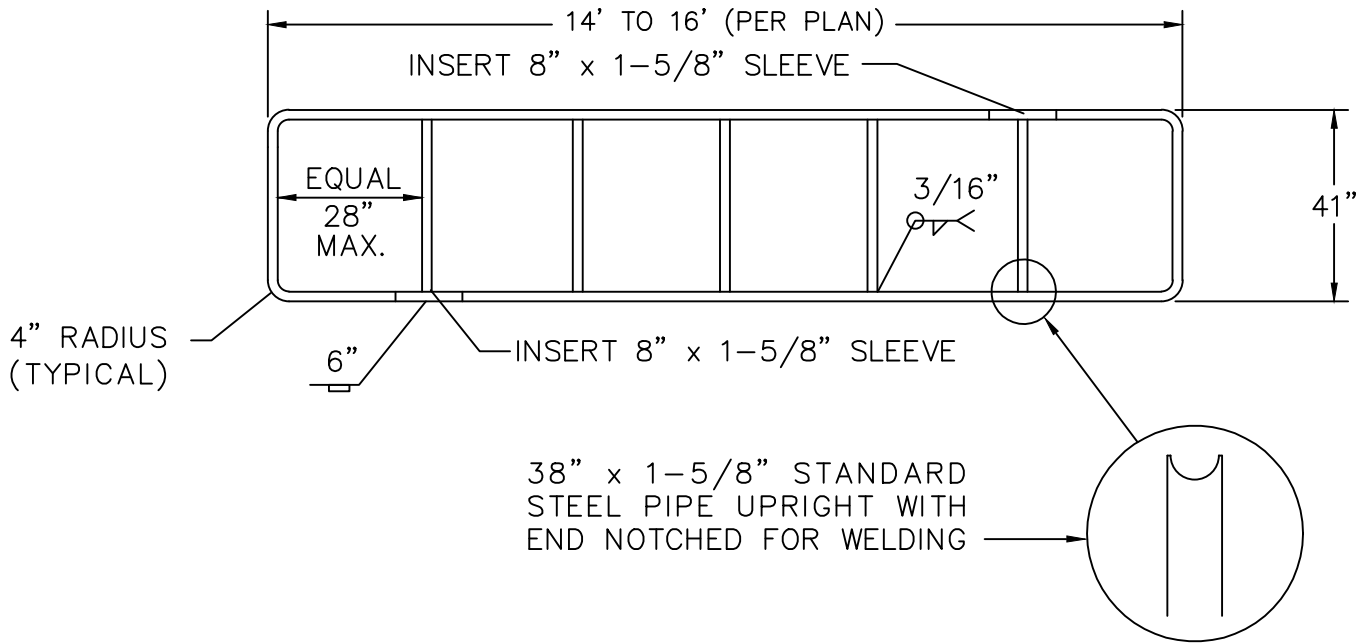

NOTES:

1. PIPE SHALL BE ASTM A53 GRADE 'B'.
2. WELD AND GRIND SMOOTH ALL CONNECTIONS.
3. HOT DIP GALVANIZE OR PAINT WITH YELLOW ENAMEL PAINT AFTER FABRICATION.

Revision	By	Apprvd	Date
New		PN	09/11/00
Updated	SJ	SS	03/01/12
Revised	SJ	GM	01/30/13
Revised	SN	KK	05/23/23

CITY OF VISTA
STANDARD DRAWING

SEWER EASEMENT GATE

[Signature]

CITY ENGINEER, DATE
RCE 55075

DRAWING NUMBER: **SWR-21B**

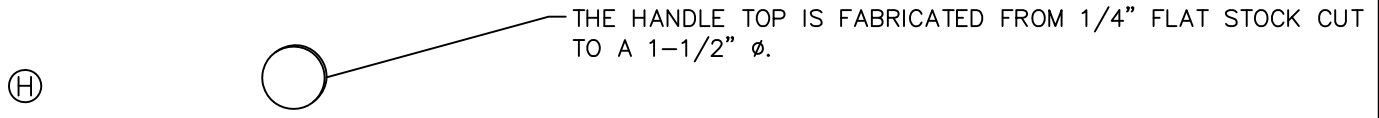
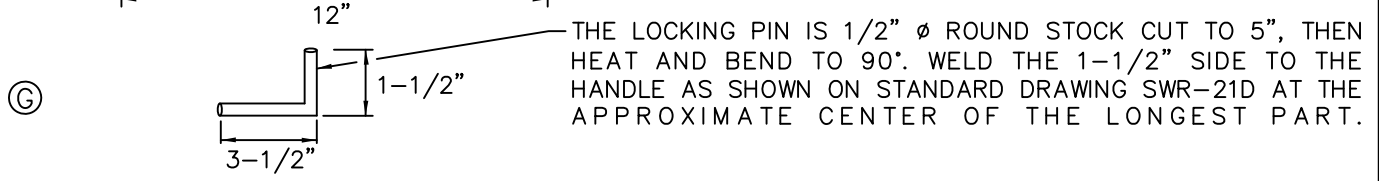
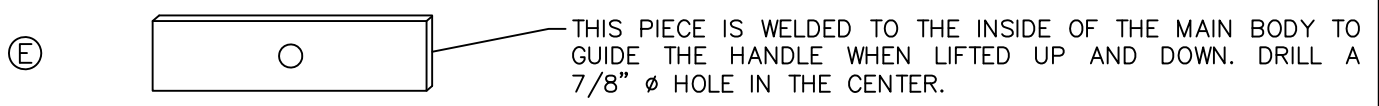
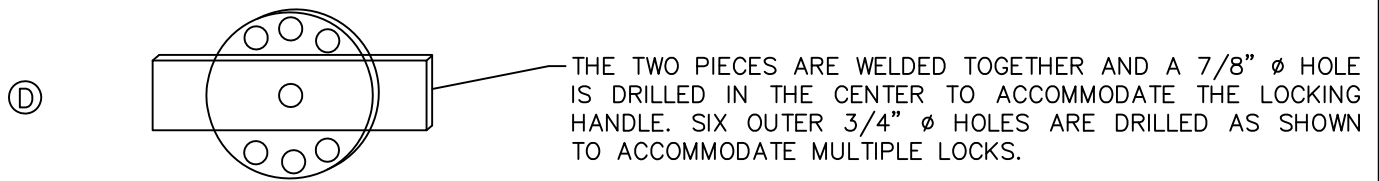
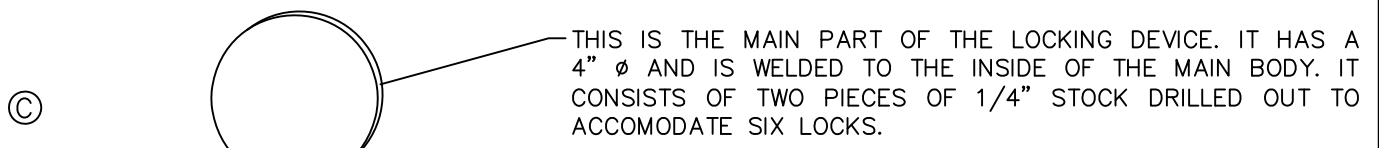
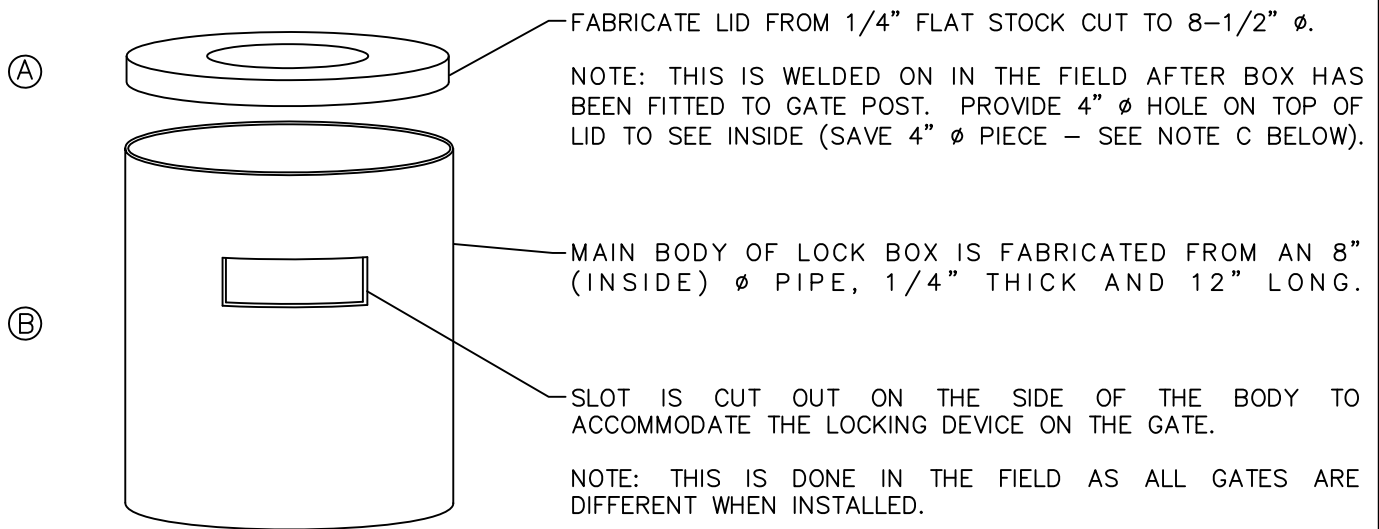

Revision	By	Apprvd	Date
New		PN	09/11/00
Updated	SJ	SS	03/01/12
Revised	SJ	GM	01/30/13

CITY OF VISTA
STANDARD DRAWING

EASEMENT GATE BARREL LOCK ASSEMBLY

[Signature]

CITY ENGINEER, DATE
RCE 55075

DRAWING NUMBER: **SWR-21C**

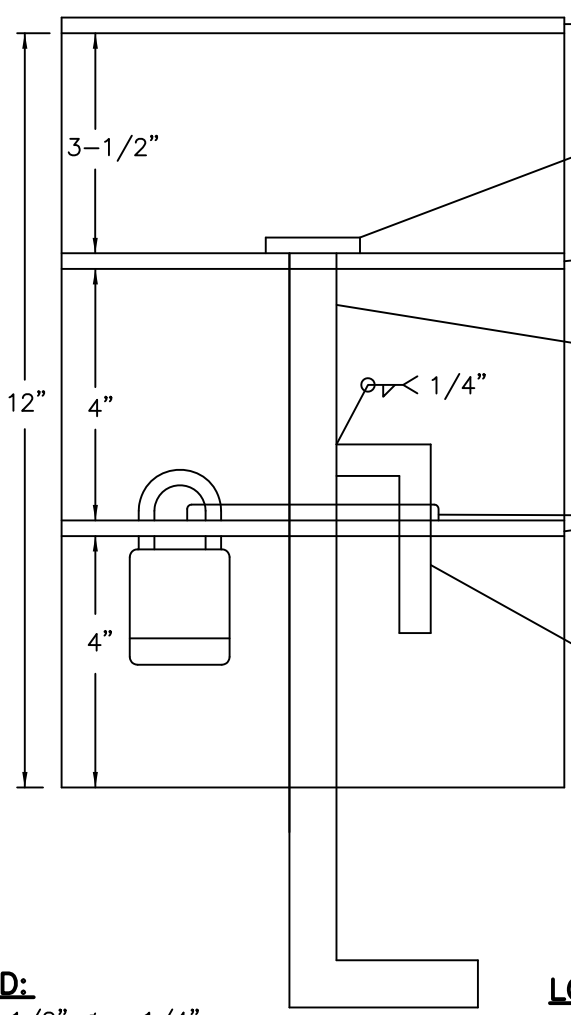

LID: TACK WELD IN FIELD.

HANDLE TOP: TACK WELD TO TOP END OF HANDLE IN FIELD.

SUPPORT BAR: THIS IS THE MOST IMPORTANT PART OF THE ASSEMBLY - IT MUST BE EXACT.

HANDLE: THE UPPER PORTION MUST STICK UP THROUGH SUPPORT BAR. ALLOW FOR CLEARANCE OF LOCKING PIN TO CLEAR ANY INSTALLED LOCKS.

LOCKING RING ASSEMBLY: THIS PIECE IS ASSEMBLED ACCORDING TO HOW THE HANDLE LINES UP IN THE SUPPORT BAR.

LOCKING PIN:

LID:
8-1/2" ϕ x 1/4"
LID WELDED ON
IN FIELD

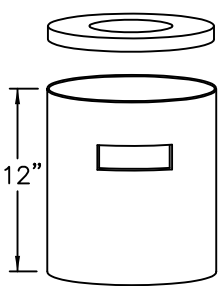

8" INSIDE ϕ x 1/4"
OR SCHEDULE 40
METAL PIPE

LOCKING RING ASSEMBLY:

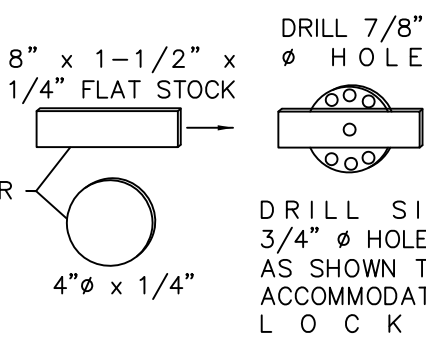

SUPPORT BAR:

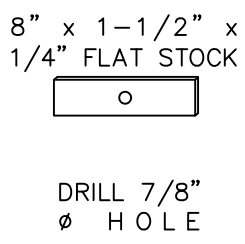

HANDLE:

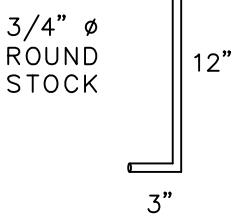

HANDLE TOP:

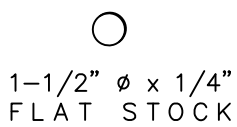

LOCKING PIN:

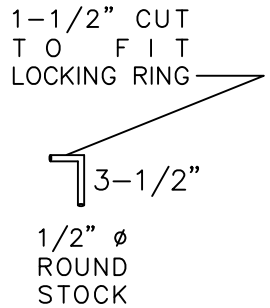

Revision	By	Apprvd	Date
New		PN	09/11/00
Updated	SJ	SS	04/04/12
Revised	SJ	GM	01/30/13

CITY OF VISTA
STANDARD DRAWING

EASEMENT GATE BARREL LOCK ASSEMBLY

[Signature]

CITY ENGINEER, DATE
RCE 55075

DRAWING NUMBER: **SWR-21D**

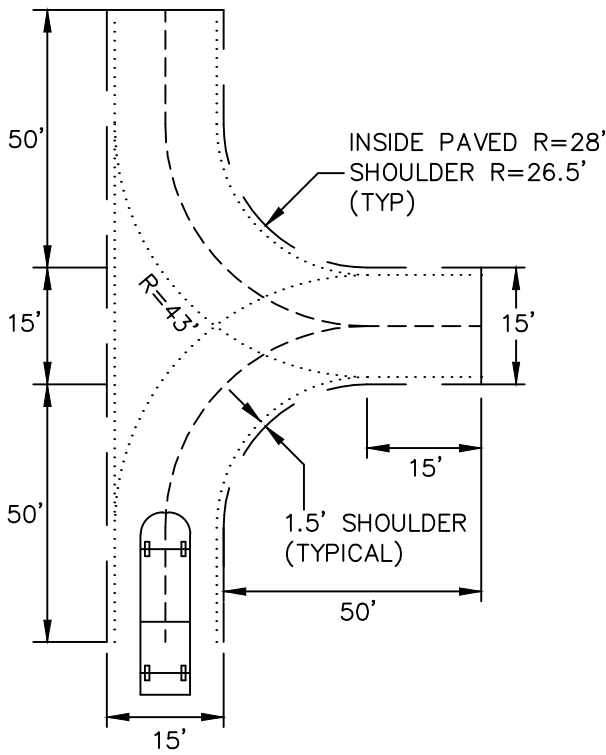

TYPE 1:
HAMMERHEAD TURN AROUND

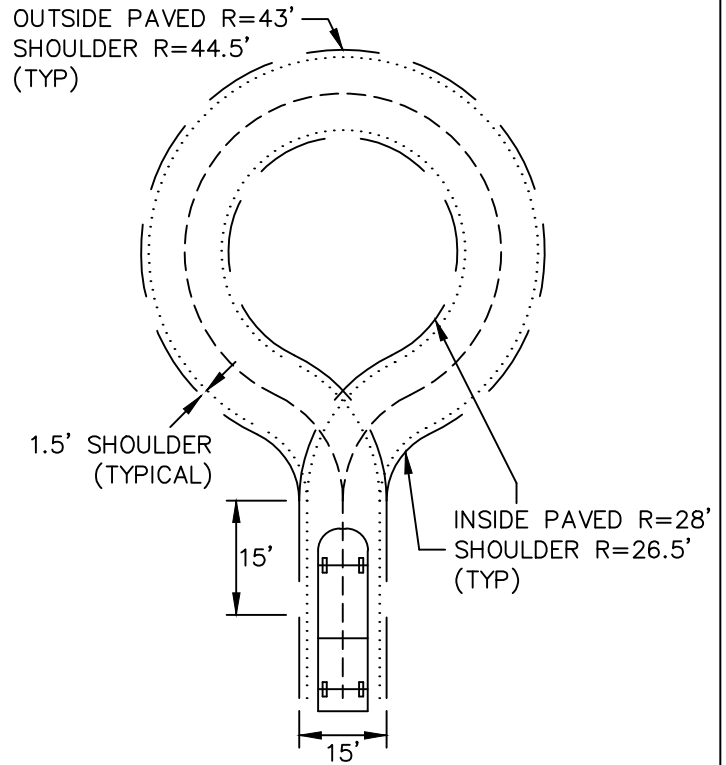

TYPE 2:
CUL-DE-SAC TURN AROUND

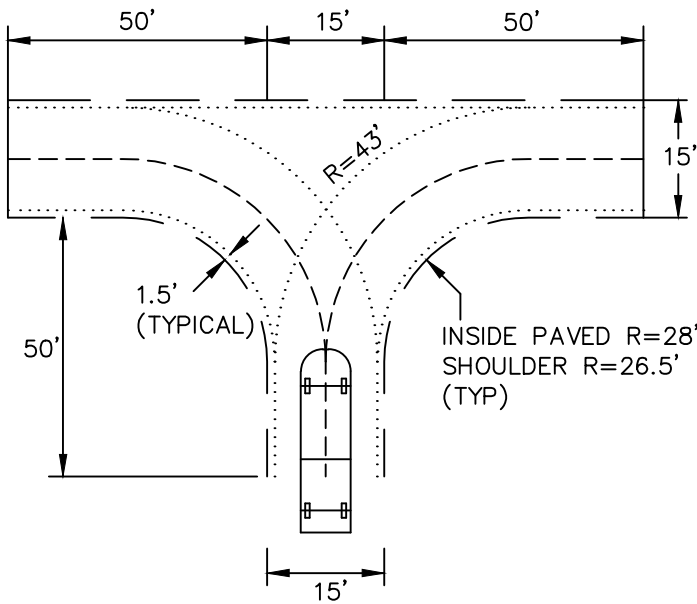

TYPE 3:
HAMMERHEAD "T" TURN AROUND

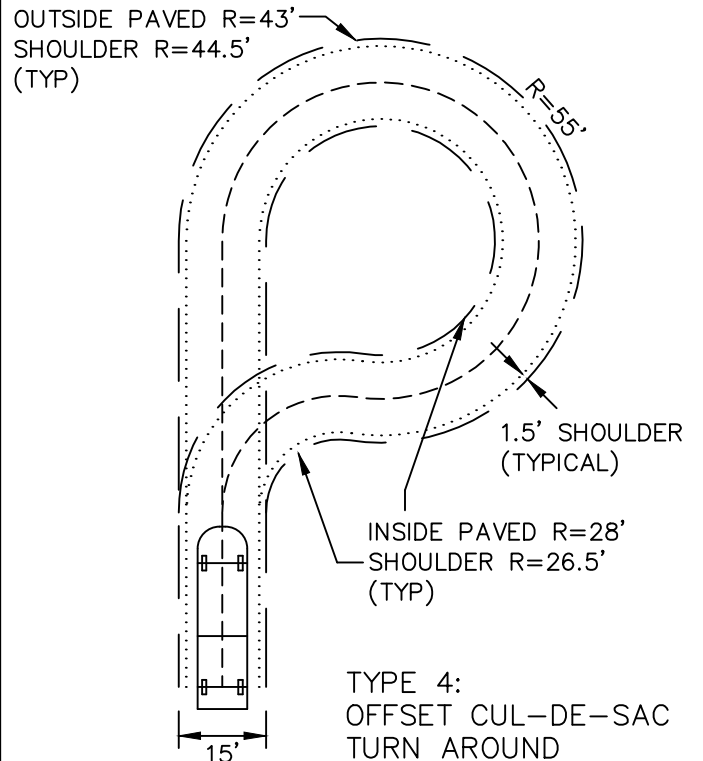

TYPE 4:
OFFSET CUL-DE-SAC
TURN AROUND

1. SPECIFY TURN AROUND BY TYPE NUMBER OR AS OTHERWISE APPROVED BY CITY ENGINEER.
2. FOR CUSTOM DESIGN, DESIGN VEHICLE IS A VACTOR 2100 ON A FREIGHTLINER 114SD CHASSIS WITH INSIDE TIRE TURNING RADIUS OF 28', OUTSIDE TIRE RADIUS OF 43', AND 45' OUTSIDE REAR BUMPER RADIUS TO OBSTRUCTIONS. CONTACT SANITATION ENGINEERING FOR VEHICLE SPECIFIC DIMENSIONS. ADEQUACY OF CUSTOM DESIGN TO BE DEMONSTRATED WITH AUTOTURN OR EQUIVALENT.

Revision	By	Apprvd	Date
New	TT		11/14/03
Updated	TR	SS	03/01/12
Revised	GL	GM	05/07/14
Updated	SN	KK	05/23/23

CITY OF VISTA
STANDARD DRAWING

**SEWER ACCESS ROAD TURN
AROUND TYPES**

[Signature]
CITY ENGINEER, DATE
RCE 55075

DRAWING
NUMBER: **SWR-22**

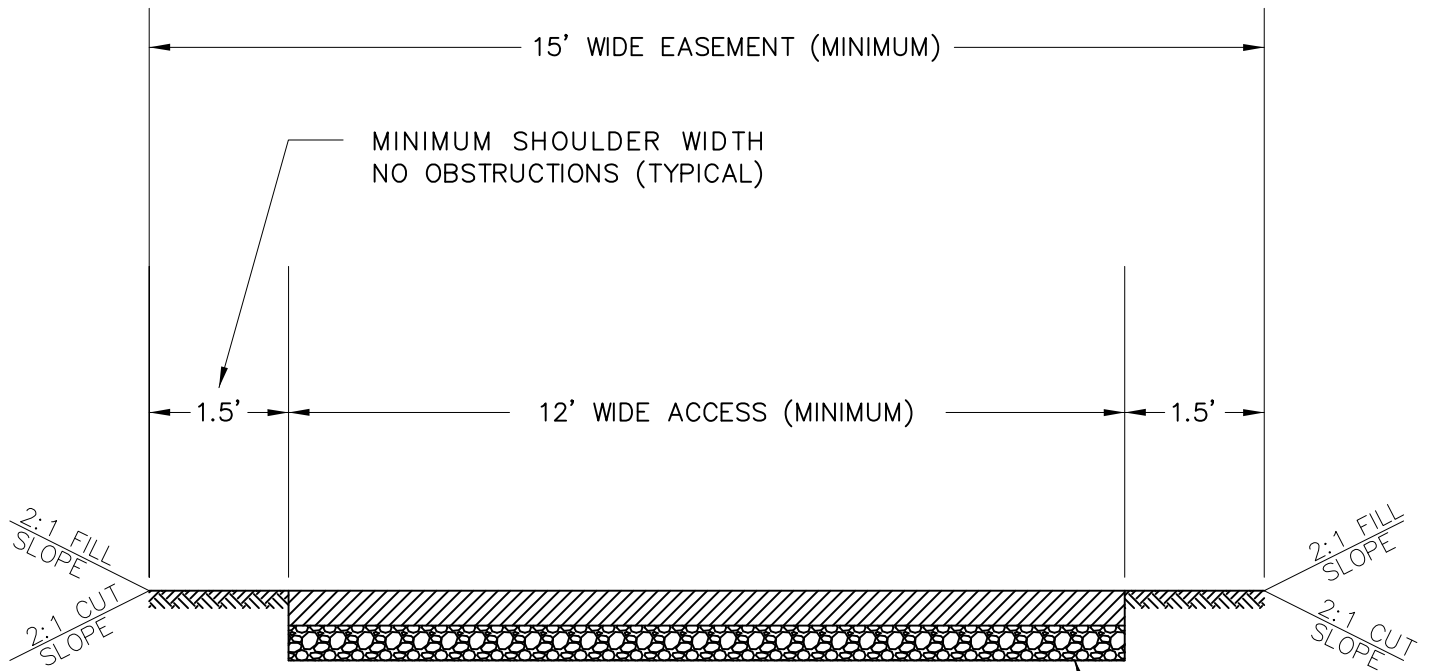

STREET STRUCTURAL SECTION SHALL BE BASED ON A MINIMUM TRAFFIC INDEX (T.I.) = 5.0 AND A KNOWN SUBGRADE "R" VALUE AS DETERMINED BY A GEOTECHNICAL ENGINEER

NOTES:

1) MINIMUM ACCESS ROAD STRUCTURAL SECTION ALTERNATIVE TYPES:

- TYPE A: MINIMUM 3" THICK OF 3/4" GRAVEL OVER 4" CLASS 2 AGGREGATE BASE
- TYPE B: MINIMUM 3" A.C. OVER 4" CLASS 2 AGGREGATE BASE
- TYPE C: MINIMUM 5" P.C.C. (WITH BROOM OR GROOVE FINISH AS DIRECTED BY CITY ENGINEER) OVER 4" CLASS 2 AGGREGATE BASE

2) STREET CROSS SLOPE SHALL BE ONE OF THE FOLLOWING:

- ALTERNATIVE A: -2% SLOPE FROM CROWN C/L TO THE OUTSIDE EDGES OF THE PAVEMENT
- ALTERNATIVE B: -2% SLOPE TO THE CENTER OF THE PAVEMENT
- ALTERNATIVE C: -2% SLOPE TO THE LEFT SIDE OF THE PAVEMENT
- ALTERNATIVE D: -2% SLOPE TO THE RIGHT SIDE OF THE PAVEMENT

Revision	By	Apprvd	Date	CITY OF VISTA STANDARD DRAWING	
New	GL	EA	01/31/13	SEWER ACCESS ROAD STRUCTURAL SECTIONS	CITY ENGINEER, DATE RCE 55075
					DRAWING NUMBER: SWR-23

TABLE 1 – DROP TO MAIN							
SEWER SIZE	8"	10"	12"	15"	18"	21"	24"
DROP TO MAIN	1.2'	1.3'	1.4'	1.8'	2.0'	2.2'	2.4'

SEWER LATERAL TABLES

A SEWER LATERAL TABLE (SEE EXAMPLE BELOW) SHALL BE INCLUDED IN THE IMPROVEMENT PLANS FOR ALL LATERALS. AT A MINIMUM THE LATERAL TABLE SHALL INCLUDE THE FOLLOWING:

1. SEQUENCE NUMBER
2. LOT NUMBER
3. SEWER MAIN STATION
4. INVERT AT SEWER MAIN (INVERT ELEVATION OF COLLECTION SEWER AT LATERAL CONNECTION)
5. LENGTH (DISTANCE FROM SEWER MAIN CENTERLINE TO PROPERTY LINE) LESS 2' (THE APPROXIMATE INSTALLED LENGTH OF A LATERAL WYE AND 1/8TH BEND)
6. DROP TO MAIN (SEE TABLE 1 ABOVE)
7. INVERT ELEVATION OF LATERAL AT PROPERTY LINE
8. SLOPE IN % = $\frac{((\text{ITEM 7} - (\text{ITEM 4} + \text{ITEM 6})) * 100)}{(\text{ITEM 5} - 2.0')}$, WHICH SHALL BE GREATER THAN 2% FOR A FOUR INCH (4") DIAMETER LATERAL OR 1% FOR A SIX INCH DIAMETER (6" ϕ) LATERAL
9. GROUND ELEVATION AT PROPERTY LINE
10. DEPTH OF LATERAL (GROUND ELEVATION – LATERAL INVERT) AT PROPERTY LINE
11. PAD ELEVATION OF BUILDING BEING SERVED
12. RIM ELEVATION OF NEXT UPSTREAM MANHOLE (MH)
13. BACKWATER VALVE REQUIRED ON LATERAL – YES OR NO – REQUIRED WHEN UPSTREAM MANHOLE (MH) RIM ELEVATION IS HIGHER THAN THE HOUSE PAD ELEVATION
14. REMARKS (SUCH AS "DEEP CUT LATERAL")

TABLE SHALL BE PRESENTED IN THE FORM SHOWN BELOW:

SEWER LATERAL TABLE													
SEQ. NO.	LOT NO.	STREET STATION OF LATERAL AT MAIN	INVERT AT MAIN IE	LENGTH OF LATERAL	DROP TO MAIN	LATERAL ELEV. AT PL IE	LATERAL SLOPE %	GROUND ELEV. AT PL	DEPTH BELOW PL PL TO IE	PAD ELEV. FT.	UPSTREAM MH RIM ELEV.	BACKWATER VALVE REQ'D	REMARKS

Revision	By	Apprvd	Date	<p align="center">CITY OF VISTA STANDARD DRAWING</p>									
New	TR	GM	01/31/13										
				<p align="center">SEWER LATERAL TABLES</p>								CITY ENGINEER, DATE RCE 55075	
												DRAWING NUMBER: SWR-24	

SEE SAN DIEGO REGIONAL STANDARD DRAWING:

SC-01 (SEWER CLEANOUT)

Revision	By	Apprvd	Date	CITY OF VISTA STANDARD DRAWING	
New	SJ	GM	01/31/13		
				STANDARD RESIDENTIAL SEWER LATERAL AND CLEANOUT	CITY ENGINEER, DATE RCE 55075
					DRAWING NUMBER: SWR-25

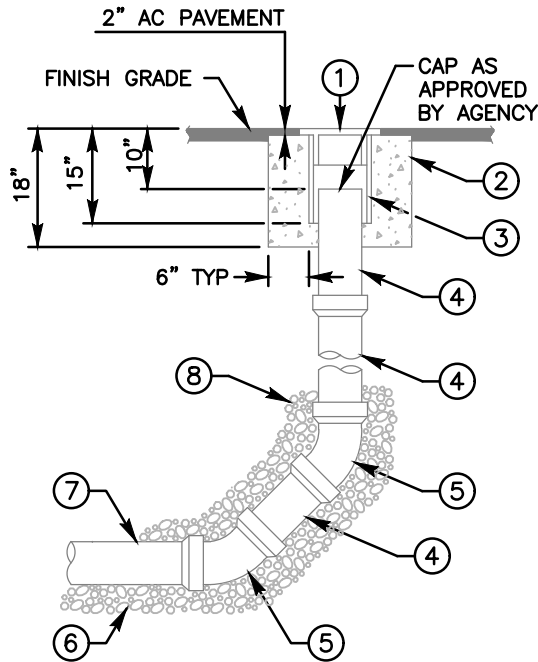

TYPE A
MAINS FOR 6" AND 8"

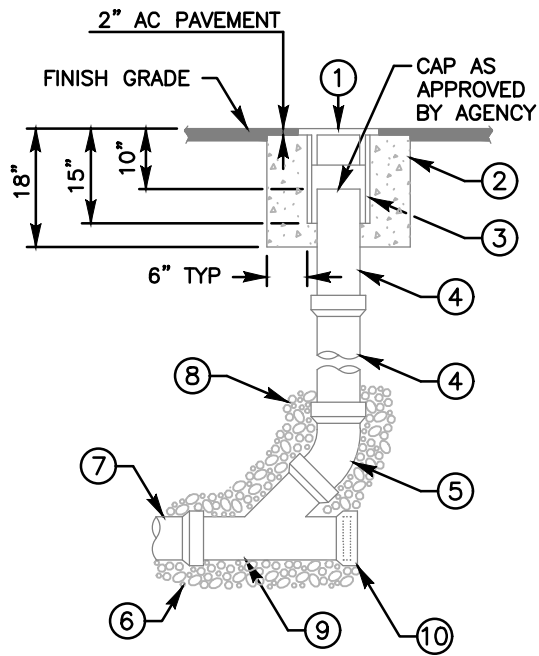

TYPE B
SEWER LATERAL
CLEANOUT

NOTES:

- 1) REFER TO AGENCY SPECIFICATIONS WHERE APPLICABLE
- 2) CLEANOUTS TO BE INSTALLED AT THE END OF MAINS WHERE INDICATED ON THE PLANS
- 3) CLEANOUT PIPE TO BE SAME SIZE AND MATERIAL AS SEWER MAIN UP TO 8"
- 4) BACKFILL TO TOP OF 45° BEND WITH 3/4" CRUSHED ROCK
- 5) MATERIALS SHALL BE SELECTED FROM THE AGENCY'S APPROVED MATERIALS LIST

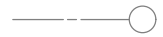

LEGEND ON PLANS

ITEM NO	SIZE AND DESCRIPTION	ITEM NO	SIZE AND DESCRIPTION
①	12" CI CLEANOUT BOX COVER MARKED 'SEWER' AND AGENCY NAME AS REQUIRED	⑤	45° ELBOW
②	CONCRETE RING	⑥	3/4" CRUSHED ROCK PIPE BEDDING
③	12" PVC, C-900 x 15" LONG (CLEANOUT BOX)	⑦	SEWER MAIN
④	SIZE x REQUIRED LENGTH PVC PIPE	⑧	3/4" CRUSHED ROCK SEE NOTE 4
		⑨	STANDARD WYE BRANCH
		⑩	INSTALL PLUG AND CONCRETE LUG

Revision	By	Approved	Date	SAN DIEGO REGIONAL STANDARD DRAWING	SEWER CLEANOUT	RECOMMENDED BY THE SAN DIEGO REGIONAL STANDARDS COMMITTEE <i>Samsin Engeda</i> 03/24/2022 Chairperson R.C.E. 52241 Date
ORIGINAL		Kercheval	12/75			
Reviewed	BK	B. KNOLL	04/15			
Reviewed	BK	B. KNOLL	10/18			
Reviewed	RP	S. Engeda	03/22			
DRAWING NUMBER SC-01						

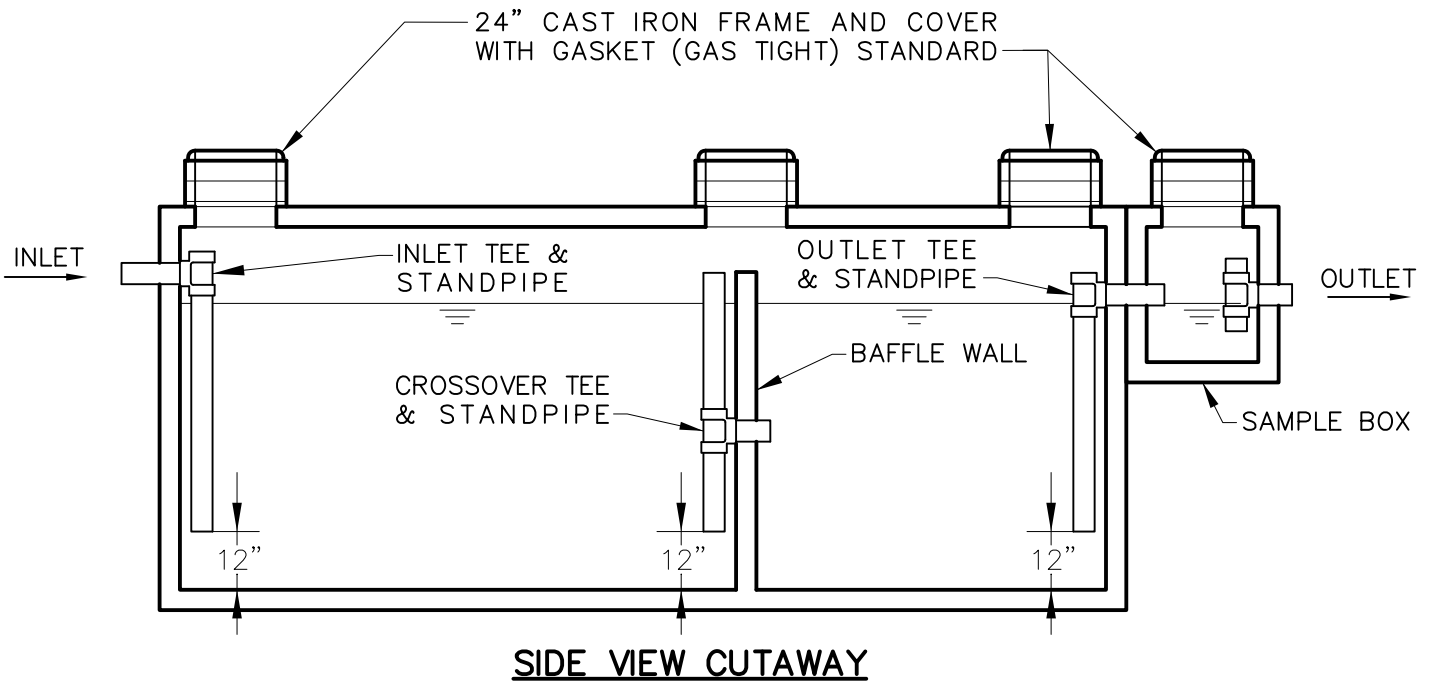

SIDE VIEW CUTAWAY

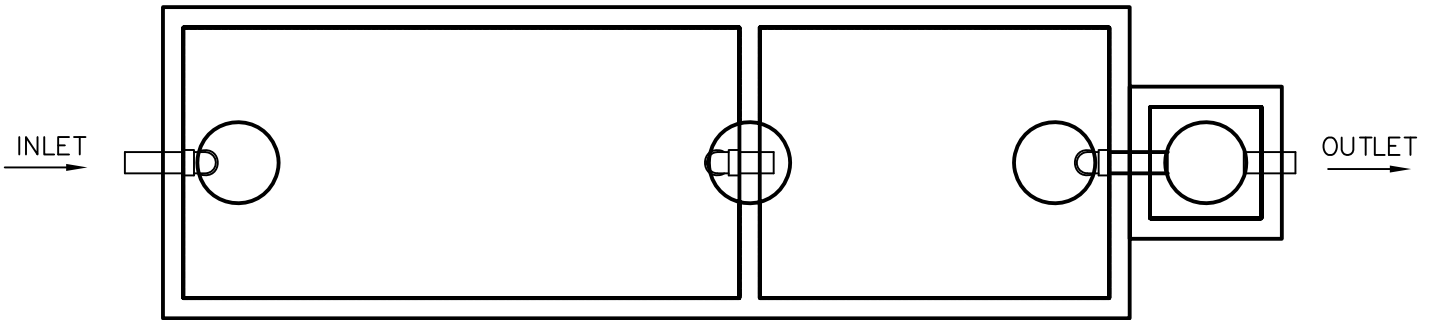

TOP VIEW (LIDS REMOVED)

NOTES:

1. GREASE INTERCEPTOR SHALL BE SIZED IN ACCORDANCE WITH THE LATEST EDITION OF THE CALIFORNIA PLUMBING CODE (CPC) REQUIREMENTS.
2. GREASE INTERCEPTORS SHALL BE DESIGNED, CONSTRUCTED, TESTED, AND MARKED IN ACCORDANCE WITH THE ASME A112.14.6 FOR FOG DISPOSAL SYSTEMS. SUBMIT SHOP DRAWINGS SHOWING COMPLIANCE.
3. ALL GREASE INTERCEPTORS SHALL BE PROVIDED WITH SAMPLE BOX AS SHOWN.
4. ALL GREASE INTERCEPTORS SHALL HAVE A CLEANOUT INSTALLED AFTER THE SAMPLE BOX ON THE PRIVATE LATERAL AND AT INTERVALS REQUIRED BY THE CPC.
5. INTERCEPTORS SHALL HAVE A SANITARY TEE LOCATED INSIDE THE SAMPLE BOX ON THE DISCHARGE SIDE OF THE SAMPLE BOX.
6. INTERCEPTOR BOX AND COVER SHALL BE DESIGNED FOR HS-20 TRAFFIC LOADING.
7. EXCAVATION SHALL BE BEDDED WITH SUITABLE GRANULAR MATERIAL AND SHALL BE COMPACTED TO 90% MAXIMUM DRY DENSITY OR TO THE REQUIREMENTS OF THE GEOTECHNICAL ENGINEER

Revision	By	Apprvd	Date	CITY OF VISTA STANDARD DRAWING	
New	SJ	GM	01/31/13		
Updated	GL	EA	05/07/14	DRAWING NUMBER: SWR-26	

SEE SAN DIEGO REGIONAL STANDARD DRAWINGS:
SM-01 (48" DIAMETER PRECAST MANHOLE INSTALLATION)
 AND
SM-02 (60" DIAMETER PRECAST MANHOLE INSTALLATION)

NOTE: COV & BSD REQUIRE 60" MANHOLES PER SWR-04/SM-02 FOR NEW MANHOLE INSTALLATIONS. USE OF 48" MANHOLE RESERVED FOR AREAS OF UTILITY CONFLICT AND REQUIRE SEWER ENGINEERING MANAGER APPROVAL. ALL MANHOLES TO BE EPOXY LINED (MIN. 125-MIL) WITH RAVEN 405 (OR APPROVED EQUAL) AND SPARK TESTED PER GREENBOOK SPECIFICATIONS.

Revision	By	Apprvd	Date	CITY OF VISTA STANDARD DRAWING	
New	SJ	GM	01/31/13		
Updated	SN	KK	05/23/23	DRAWING NUMBER: SWR-27	

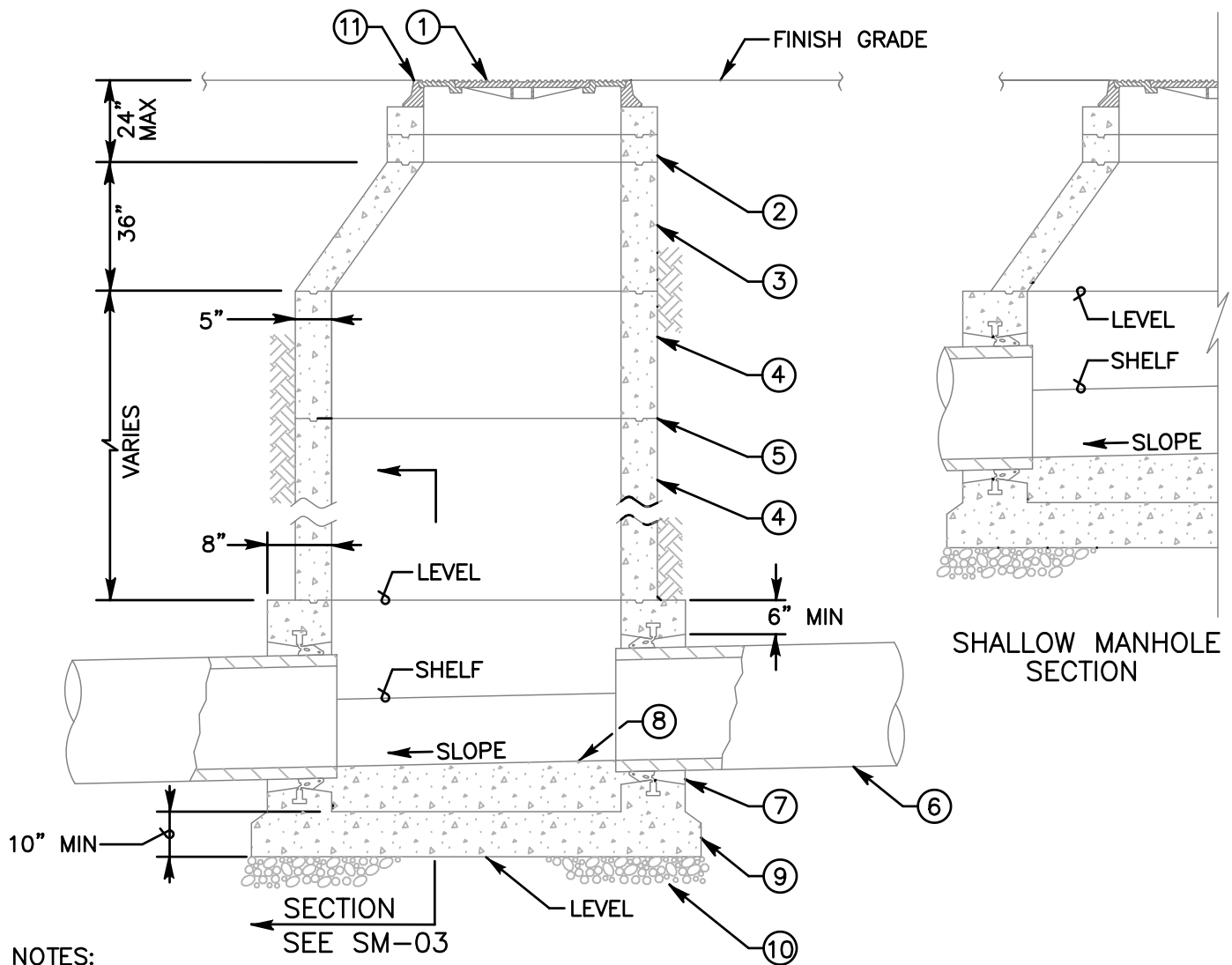

NOTES:

- 1) REFER TO AGENCY SPECIFICATIONS WHERE APPLICABLE
- 2) VERTICAL WALL OF CONE TO BE ON THE UPSTREAM SIDE OF MANHOLE SEE SM-05 FOR ACCESS LOCATIONS
- 3) FOR MANHOLE BASES SEE SM-03
- 4) MANHOLES FOR MAINS 18" AND LARGER SHALL BE COATED AND LINED PER SM-07
- 5) MATERIALS SHALL BE SELECTED FROM THE AGENCY'S APPROVED MATERIALS LIST

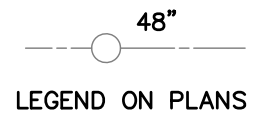

ITEM NO	SIZE AND DESCRIPTION	ITEM NO	SIZE AND DESCRIPTION
①	36" MANHOLE FRAME AND TWO CONCENTRIC COVERS SEE S.D.R.S.D. M-3	⑦	MANHOLE PIPE CONNECTOR SEE SM-04
②	36" DIA GRADE RING(S) 6" TO 18" HIGH	⑧	FIELD INSTALLED INVERT SEE SM-04
③	ECCENTRIC CONE SEE NOTE 2	⑨	CONCRETE BASE, PRECAST OR CAST IN PLACE
④	48" DIA RING(S) VARIABLE HEIGHT	⑩	6" OF 3/4" CRUSHED ROCK
⑤	WATER TIGHT JOINTS SEE SM-05	⑪	MANHOLE DETAIL SEE SM-05
⑥	SEWER MAIN		

Revision	By	Approved	Date	SAN DIEGO REGIONAL STANDARD DRAWING	RECOMMENDED BY THE SAN DIEGO REGIONAL STANDARDS COMMITTEE
ORIGINAL		Kercheval	12/75		
Reviewed	BK	B. KNOLL	04/15	48" DIAMETER PRECAST MANHOLE INSTALLATION	03/24/2022 Chairperson R.C.E. 52241 Date
Reviewed	BK	B. KNOLL	10/18		
Reviewed	RP	S. Engeda	03/22		
				DRAWING NUMBER	SM-01

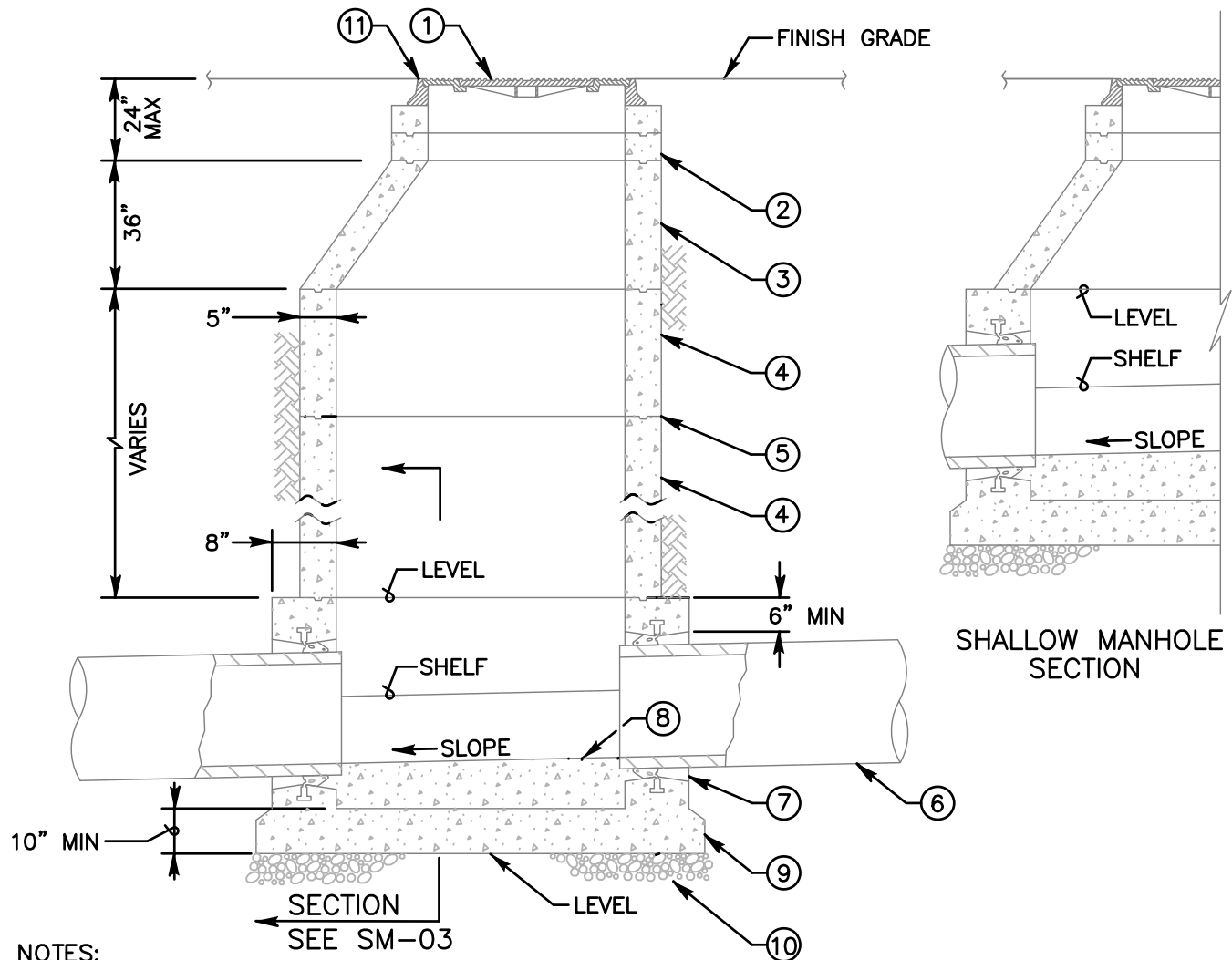

NOTES:

- 1) REFER TO AGENCY SPECIFICATIONS WHERE APPLICABLE
- 2) VERTICAL WALL OF CONE TO BE ON THE UPSTREAM SIDE OF MANHOLE SEE SM-05 FOR ACCESS LOCATIONS
- 3) FOR MANHOLE BASES SEE SM-03
- 4) MANHOLES FOR MAINS 18" AND LARGER SHALL BE COATED AND LINED PER SM-07
- 5) MATERIALS SHALL BE SELECTED FROM THE AGENCY'S APPROVED MATERIALS LIST

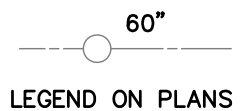

ITEM NO	SIZE AND DESCRIPTION	ITEM NO	SIZE AND DESCRIPTION
①	36" MANHOLE FRAME AND TWO CONCENTRIC COVERS SEE S.D.R.S.D. M-3	⑦	MANHOLE PIPE CONNECTOR SEE SM-04
②	36" DIA GRADE RING(S) 6" TO 18" HIGH	⑧	FIELD INSTALLED INVERT SEE SM-04
③	ECCENTRIC CONE SEE NOTE 2	⑨	CONCRETE BASE, PRECAST OR CAST IN PLACE
④	60" DIA RING(S) VARIABLE HEIGHT	⑩	6" OF 3/4" CRUSHED ROCK
⑤	WATER TIGHT JOINTS SEE SM-05	⑪	MANHOLE DETAIL SEE SM-05
⑥	SEWER MAIN		

Revision	By	Approved	Date	SAN DIEGO REGIONAL STANDARD DRAWING 60" DIAMETER PRECAST MANHOLE INSTALLATION	RECOMMENDED BY THE SAN DIEGO REGIONAL STANDARDS COMMITTEE <i>Samantha Engeda</i> 03/24/2022 Chairperson R.C.E. 52241 Date
ORIGINAL		Kercheval	12/75		
Reviewed	BK	B. KNOLL	04/15		
Reviewed	BK	B. KNOLL	10/18		
Reviewed	RP	S. Engeda	03/22		
				DRAWING NUMBER	SM-02

SEE SAN DIEGO REGIONAL STANDARD DRAWING:

M-4 (MANHOLE COVER - LOCKING DEVICE)

NOTE: HINGED STYLE MANHOLE COVERS ARE NOT PERMITTED.

Revision	By	Apprvd	Date	CITY OF VISTA STANDARD DRAWING	
New	SJ	GM	01/31/13		
Updated	SN	KK	05/23/23	MANHOLE FRAME AND COVER (LOCKING DEVICE)	CITY ENGINEER, DATE RCE 55075
					DRAWING NUMBER: SWR-28

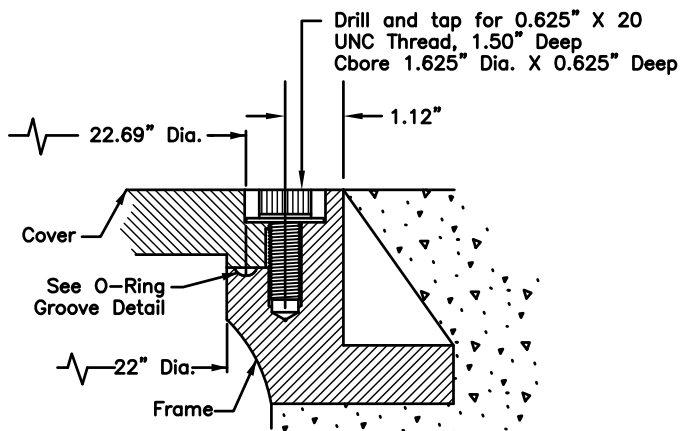

M-01 Detail:
COVER TO FRAME

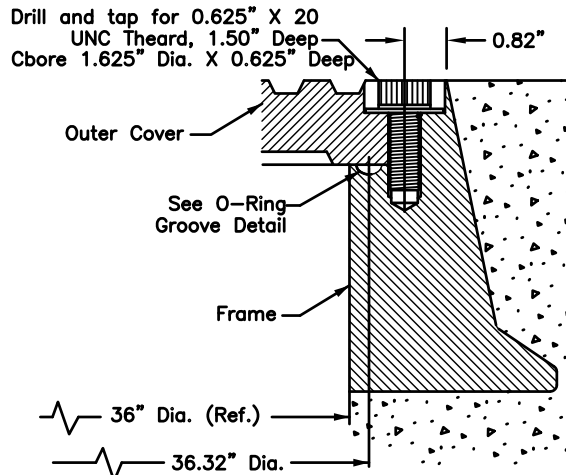

M-03A Detail:
OUTER COVER TO FRAME

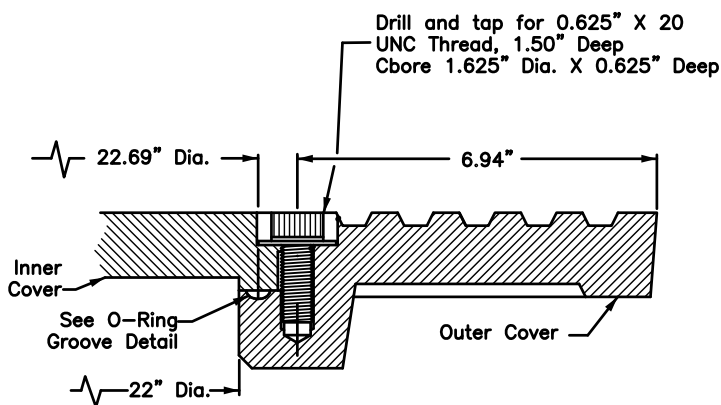

M-03A Detail:
INNER COVER TO OUTER COVER

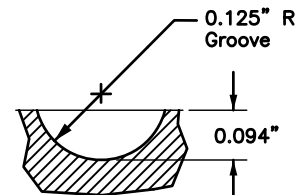

NEOPRENE O-RING
GROOVE DETAIL

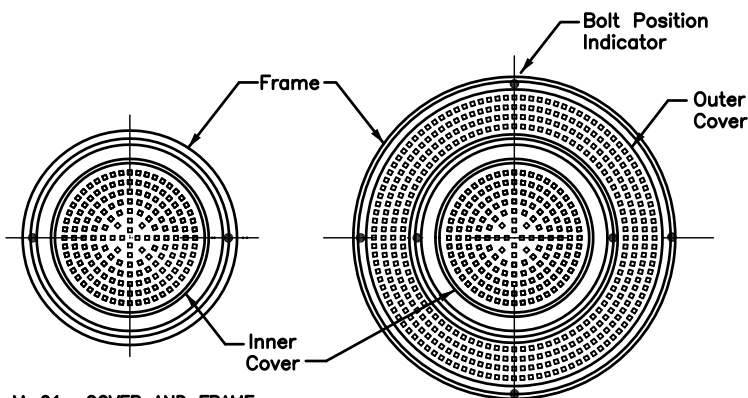

M-01 COVER AND FRAME
BOLT PLACEMENT
(See Note 3)

M-03A CONCENTRIC COVERS AND FRAME
BOLT PLACEMENT
(See Note 3)

NOTES:

1. 0.625" X 20 UNC THREAD, 316 STAINLESS STEEL SOCKET HEAD CAP SCREW AND 1.50" O.D. X 0.687" I.D. X 0.078" THICK 316 STAINLESS STEEL WASHER.
2. 0.25" NEOPRENE O-RING GASKET SHALL BE GLUED INTO MACHINED GROOVE. GLUE SHALL MEET THE REQUIREMENTS OF MIL-M-81288 (AMEND. 1)
3. BOLTDOWN PATTERNS:
 - M-01 DETAIL (24" COVER & FRAME): INSTALL TWO (2) BOLTS AT 180 DEGREES.
 - M-03A DETAIL (CONCENTRIC COVERS): BETWEEN INNER AND OUTER COVERS INSTALL TWO (2) BOLTS AT 180 DEGREES.

Revision	By	Approved	Date
ORIGINAL		Parkinson	2/95
Updated		D. Gerschoffer	12/15
Reviewed		D. Gerschoffer	10/18
Reviewed	RP	S. ENGEDA	03/22

SAN DIEGO REGIONAL STANDARD DRAWING

MANHOLE COVER - LOCKING DEVICE

RECOMMENDED BY THE SAN DIEGO REGIONAL STANDARDS COMMITTEE

Susan Engeda 03/24/2022
Chairperson R.C.E. 19246 Date

DRAWING NUMBER **M-04**

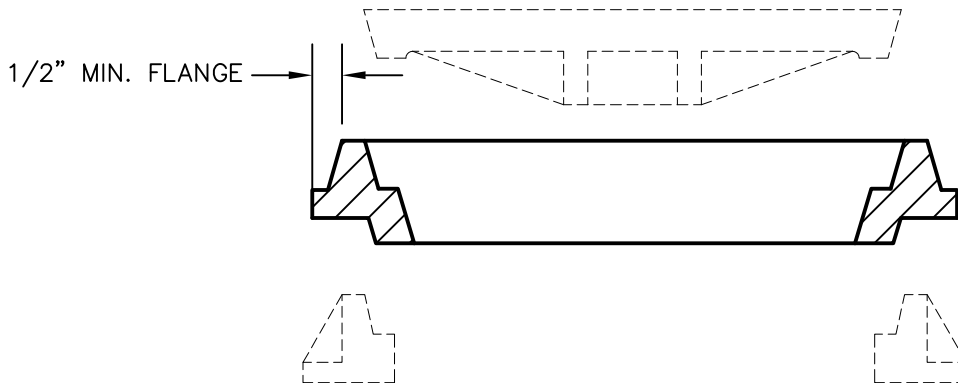

NOTES:

1. IF APPLICABLE, SUBMIT A COPY OF WRITTEN APPROVAL FROM THE JURISDICTIONAL AGENCY ALLOWING THE USE OF CAST IRON RISER RINGS FOR MANHOLE HEIGHT ADJUSTMENT.
2. MANHOLE HEIGHT ADJUSTMENT BETWEEN ONE AND TWO INCHES (1" - 2") PER RISER RING ALLOWED.
3. MANHOLE RISER RINGS SHALL BE SPECIFICALLY MANUFACTURED TO MATCH THE EXISTING MANHOLE FRAME AND COVER DIMENSIONALLY AND BY CASTING NUMBER.
4. NO MORE THAN TWO (2) CAST IRON RISER RINGS SHALL BE INSTALLED ON AN EXISTING MANHOLE FRAME.
5. FOR A HEIGHT ADJUSTMENT GREATER THAN THAT ALLOWED BY TWO (2) CAST IRON RISER RINGS, NEW CONCRETE RISERS SHALL BE USED PER SDRSD SM-01 (48" ϕ PRECAST MANHOLE INSTALLATION) AND SM-02 (60" ϕ PRECAST MANHOLE INSTALLATION).
6. RISER RING CAST IRON SHALL MEET THE REQUIREMENTS OF ASTM A48, CLASS 30.
7. RISERS SHALL HAVE A FLANGE 360 DEGREES ON THE OUTSIDE OF THE RISER. THE FLANGE SHALL EXTEND A MINIMUM OF ONE-HALF INCH ($\frac{1}{2}$ ") IN HEIGHT.
8. ALL SEATING SURFACES SHALL BE MACHINED AND ATTAIN FULL CONTACT OF MATING SURFACES SUCH THAT THE RAISED MANHOLE COVER DOES NOT "ROCK" OR MOVE ON THE ORIGINAL MANHOLE FRAME.
9. RISERS SHALL BE MARKED WITH THE FOUNDRY NAME, PATTERN REFERENCE NUMBER AND HEIGHT OF RISE (E.G.: SRF 1310 X 2).
10. CAST IRON RISER RINGS SHALL BE MANUFACTURED BY SOUTH BAY FOUNDRY (OR APPROVED EQUAL).

Revision	By	Apprvd	Date	CITY OF VISTA STANDARD DRAWING	
New	SJ	GM	01/31/13		
				CAST IRON RING COVERS	CITY ENGINEER, DATE RCE 55075
					DRAWING NUMBER: SWR-29

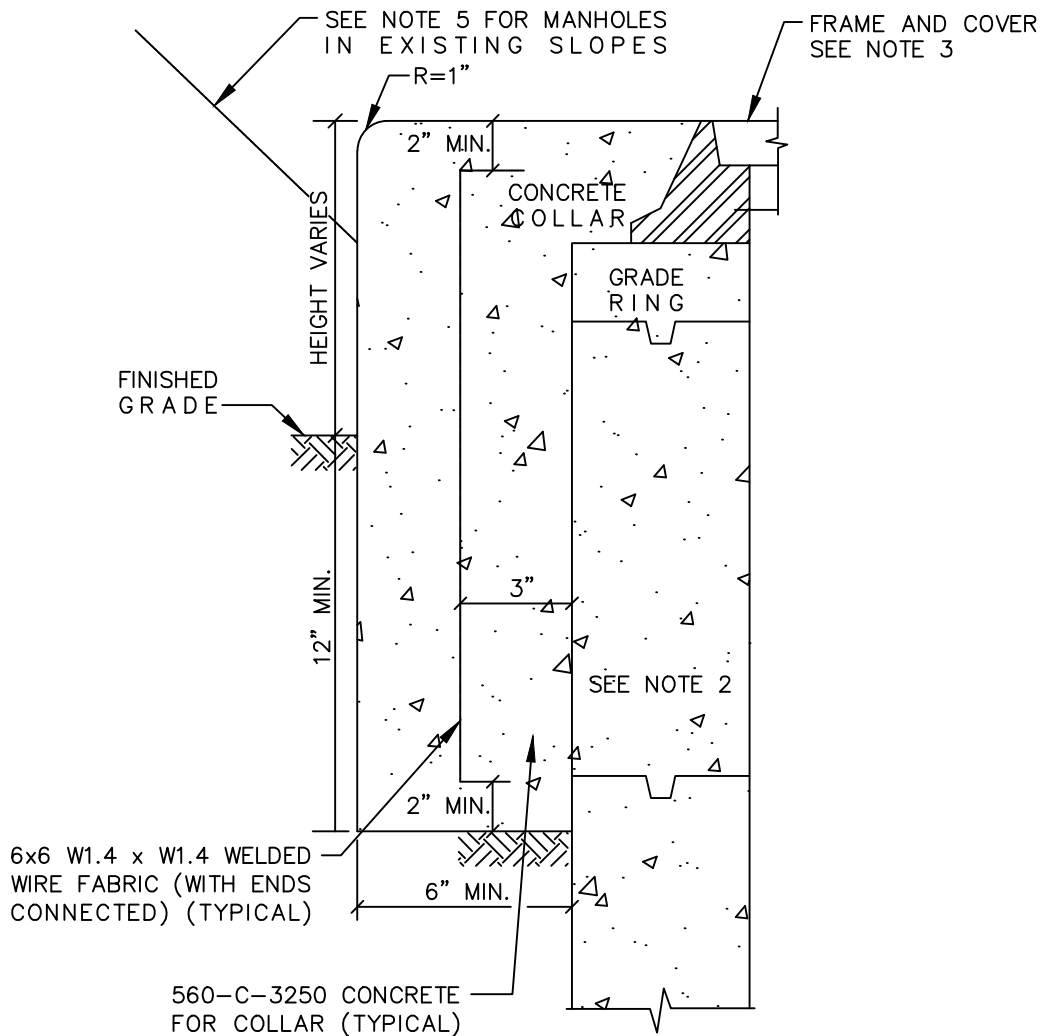

TYPE 'A' FOR UNPAVED AREAS

NOTES:

1. MANHOLE FRAME SHALL BE SET IN CLASS "C" MORTAR (2012 GREENBOOK SUBSECTION 201-5.1).
2. PRECAST MANHOLE SHALL BE PER PLAN AND PER SAN DIEGO REGIONAL STANDARD DRAWINGS:
 SM-01 (48" ϕ PRECAST MANHOLE INSTALLATION),
 SM-02 (60" ϕ PRECAST MANHOLE INSTALLATION),
 SM-03 (SEWER MANHOLE BASE),
 SM-04 (MANHOLE PIPE CONNECTORS),
 SM-05 (MANHOLE MISCELLANEOUS DETAILS).
3. MANHOLE FRAME AND COVER SHALL BE PER SAN DIEGO REGIONAL STANDARD DRAWINGS:
 M-3 (36" MANHOLE FRAME AND TWO CONCENTRIC COVERS HEAVY DUTY)
 M-4 (MANHOLE COVER - LOCKING DEVICE)
 MANHOLE FRAME AND COVER FOR TYPE 'A' LOCATIONS SHALL BE GMI COMPOSITE FRAME AND COVER, WITH TITUS LOCKING SYSTEM, DESIGNED FOR AASHTO H-20 TRAFFIC LOADING.
4. LOCKING / SEALED MANHOLE FRAMES & COVERS, WHERE SPECIFIED, SHALL NOT BE HINGED.
5. FOR MANHOLES WITHIN EXISTING SLOPES, THE UPHILL SIDE SHALL EXTEND SIX INCHES (6") ABOVE THE EXISTING GRADE. THE DOWNHILL SIDE SHALL BE VARIABLE, DEPENDING UPON THE STEEPNESS OF THE SLOPE. A TWELVE INCH (12") MINIMUM EMBEDMENT SHALL BE MAINTAINED ON ALL SIDES.

Revision	By	Apprvd	Date	CITY OF VISTA STANDARD DRAWING	
New	SJ	GM	01/31/13		
Updated	SN	KK	05/23/23	DRAWING NUMBER: SWR-30A	

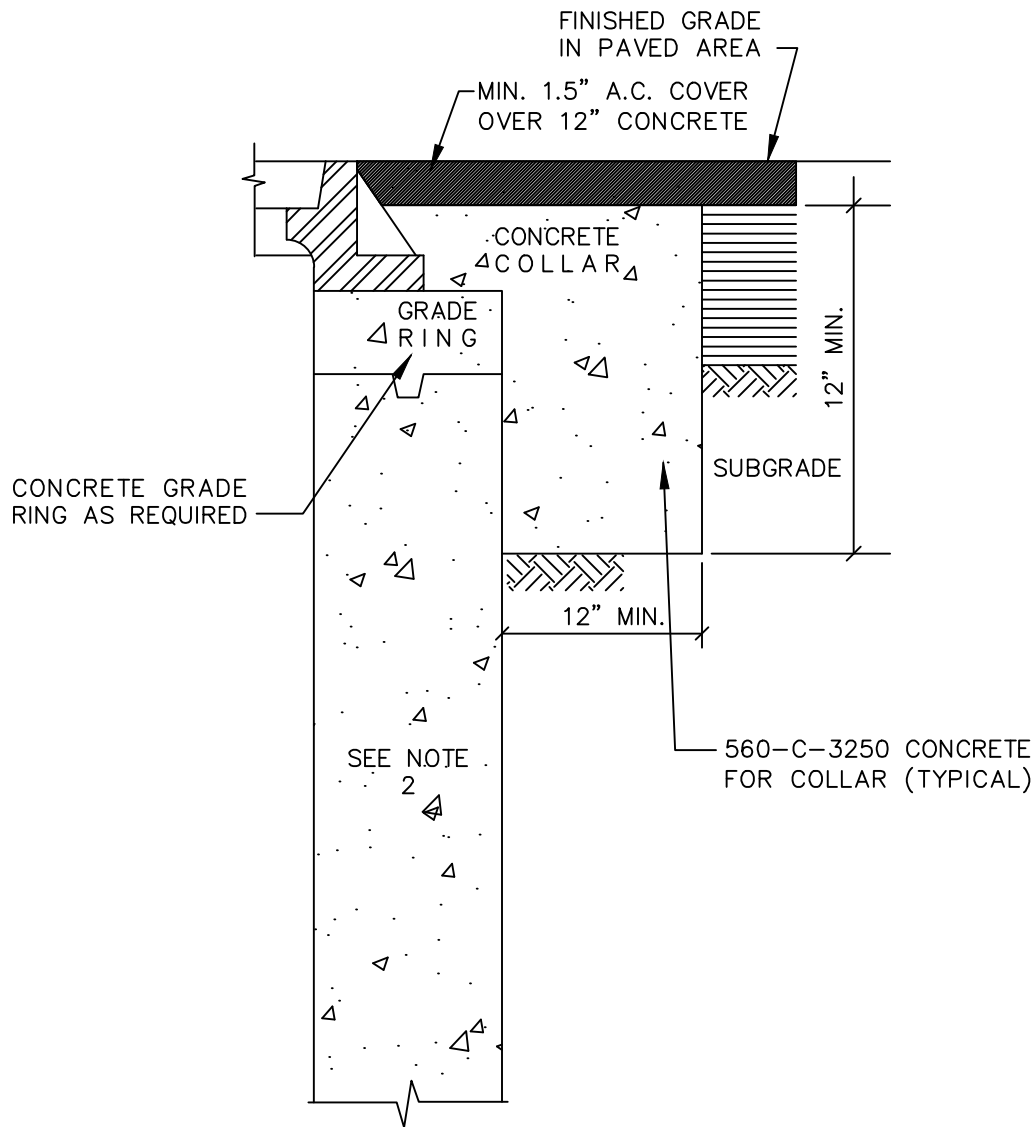

TYPE 'B' FOR PAVED AREAS

NOTES:

1. MANHOLE FRAME SHALL BE SET IN CLASS "C" MORTAR (GREENBOOK SUBSECTION 201-5.1).
2. PRECAST MANHOLE SHALL BE PER PLAN AND PER SAN DIEGO REGIONAL STANDARD DRAWINGS:
 SM-01 (48" ϕ PRECAST MANHOLE INSTALLATION),
 SM-02 (60" ϕ PRECAST MANHOLE INSTALLATION),
 SM-03 (SEWER MANHOLE BASE),
 SM-04 (MANHOLE PIPE CONNECTORS),
 SM-05 (MANHOLE MISCELLANEOUS DETAILS).
3. MANHOLE FRAME AND COVER SHALL BE PER SAN DIEGO REGIONAL STANDARD DRAWINGS:
 M-3 (36" MANHOLE FRAME AND TWO CONCENTRIC COVERS HEAVY DUTY),
 M-4 (MANHOLE COVER - LOCKING DEVICE).
4. LOCKING / SEALED MANHOLE FRAMES & COVERS, WHERE SPECIFIED, SHALL NOT BE HINGED.

Revision	By	Apprvd	Date	CITY OF VISTA STANDARD DRAWING		
New	SJ	GM	01/31/13			
Updated	SN	KK	05/23/23	DRAWING NUMBER: SWR-30B		

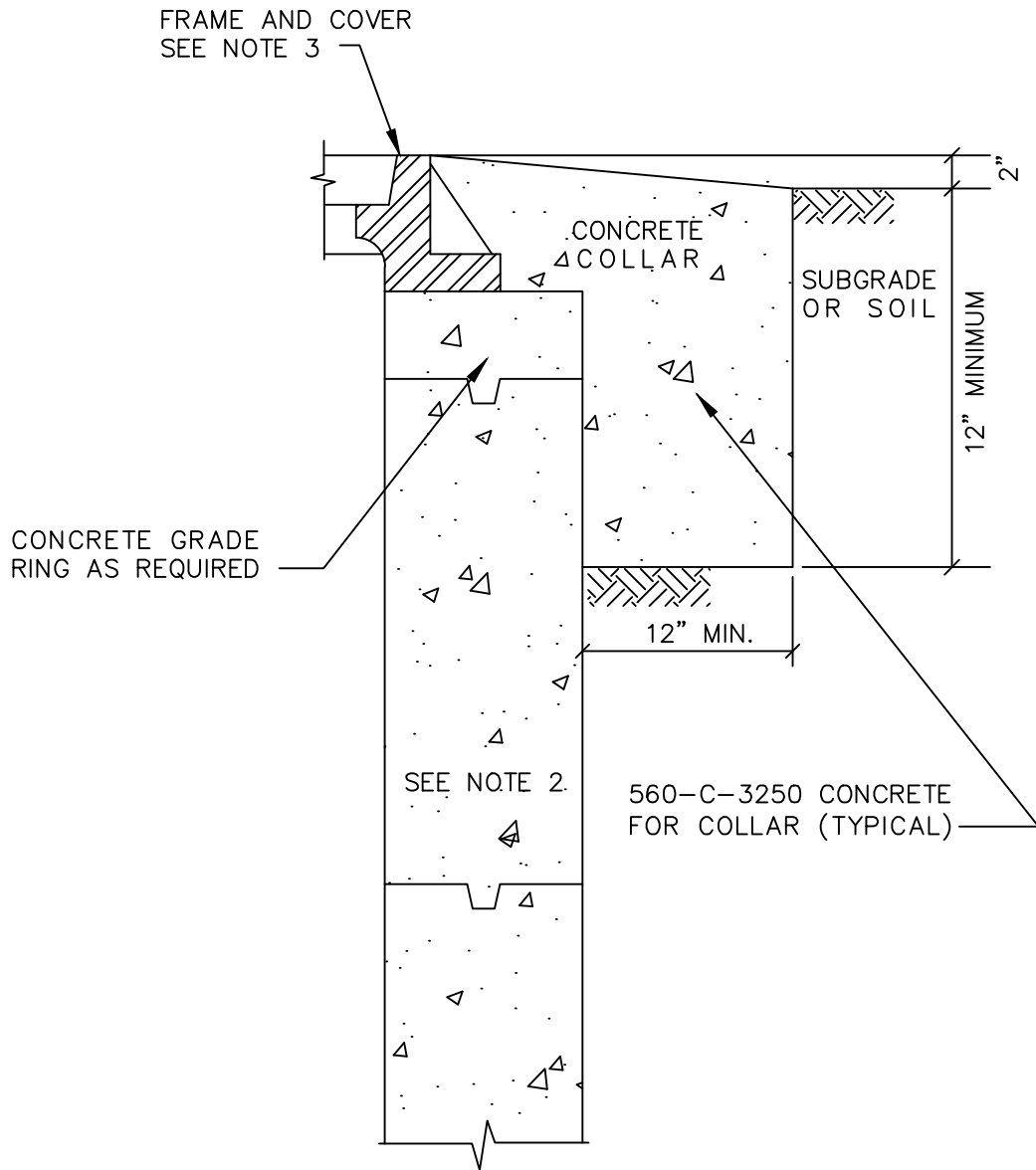

TYPE 'C' FOR UNPAVED TRAVELED WAYS

NOTES:

1. MANHOLE FRAME SHALL BE SET IN CLASS "C" MORTAR (2012 GREENBOOK SUBSECTION 201-5.1).
2. PRECAST MANHOLE SHALL BE PER PLAN AND PER SAN DIEGO REGIONAL STANDARD DRAWINGS:
 SM-01 (48" ϕ PRECAST MANHOLE INSTALLATION),
 SM-02 (60" ϕ PRECAST MANHOLE INSTALLATION),
 SM-03 (SEWER MANHOLE BASE),
 SM-04 (MANHOLE PIPE CONNECTORS),
 SM-05 (MANHOLE MISCELLANEOUS DETAILS).
3. MANHOLE FRAME AND COVER SHALL BE PER SAN DIEGO REGIONAL STANDARD DRAWINGS:
 M-3 (36" MANHOLE FRAME AND TWO CONCENTRIC COVERS HEAVY DUTY)
 M-4 (MANHOLE COVER - LOCKING DEVICE).
4. LOCKING / SEALED MANHOLE FRAMES & COVERS, WHERE SPECIFIED, SHALL NOT BE HINGED.

Revision	By	Apprvd	Date
New	SJ	GM	01/31/13
Updated	SN	KK	05/23/23

CITY OF VISTA
STANDARD DRAWING

**CONCRETE MANHOLE COLLAR
(TYPE C)**

[Signature]
CITY ENGINEER, DATE
RCE 55075

DRAWING NUMBER: **SWR-30C**

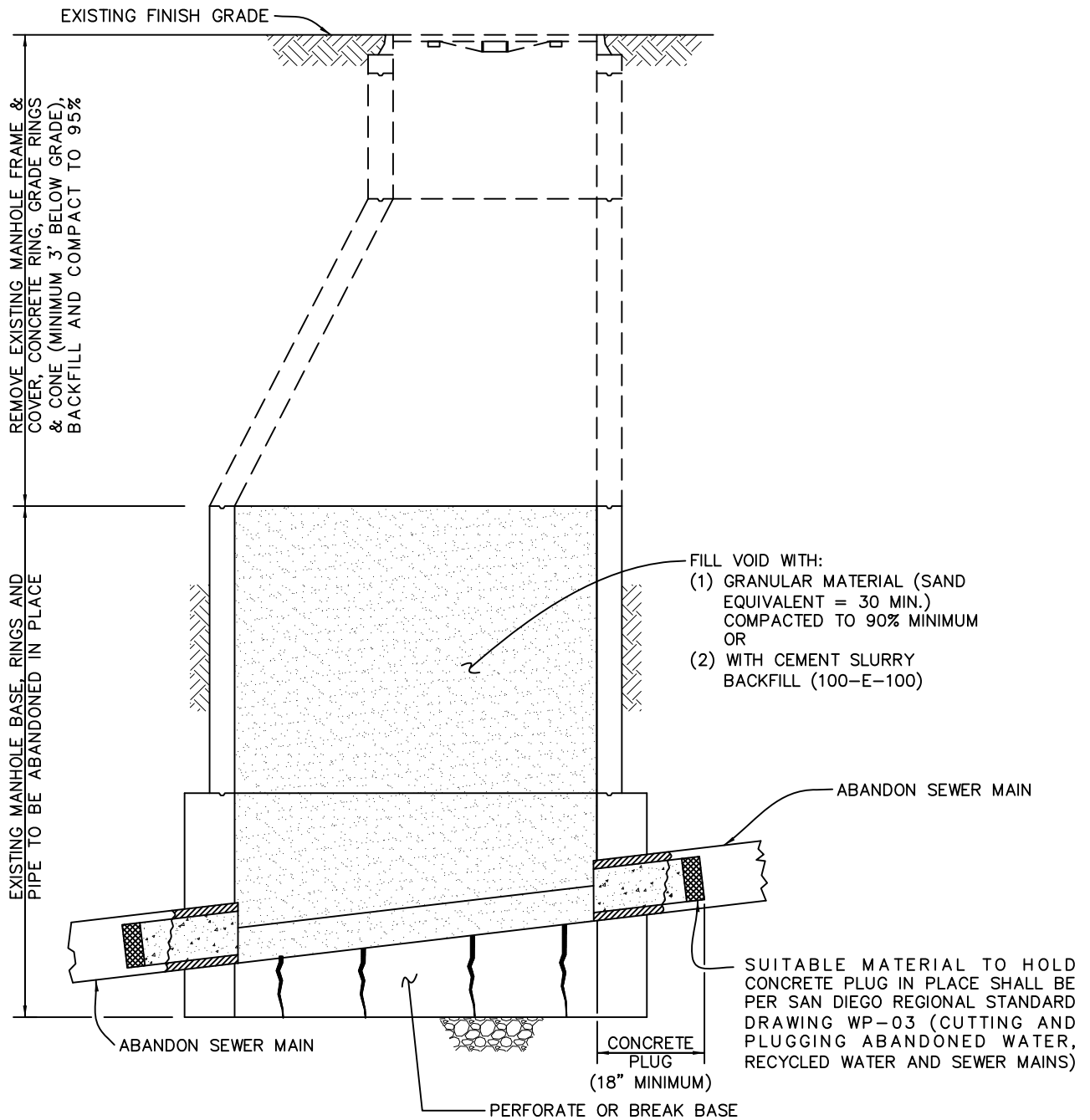

NOTES:

1. ALL SALVAGE MATERIALS SHALL BE DELIVERED TO THE CITY OF VISTA PUBLIC WORKS YARD.
2. CONTRACTOR, AT HIS OPTION AND EXPENSE, MAY REMOVE THE ENTIRE MANHOLE STRUCTURE.
3. SEE CITY OF VISTA STANDARD DRAWINGS SRF-08A AND SRF-08B (TRENCH PAVING STANDARD TYPES) FOR MINIMUM SURFACE RESTORATION REQUIREMENTS.

LEGEND

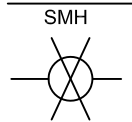

Revision	By	Apprvd	Date
New		TH	07/08/93
Updated	TR	SS	03/21/08

CITY OF VISTA
STANDARD DRAWING

**EXISTING SEWER MANHOLE
ABANDONMENT**

[Signature]
CITY ENGINEER, DATE
RCE 55075

DRAWING NUMBER: **SWR-31**

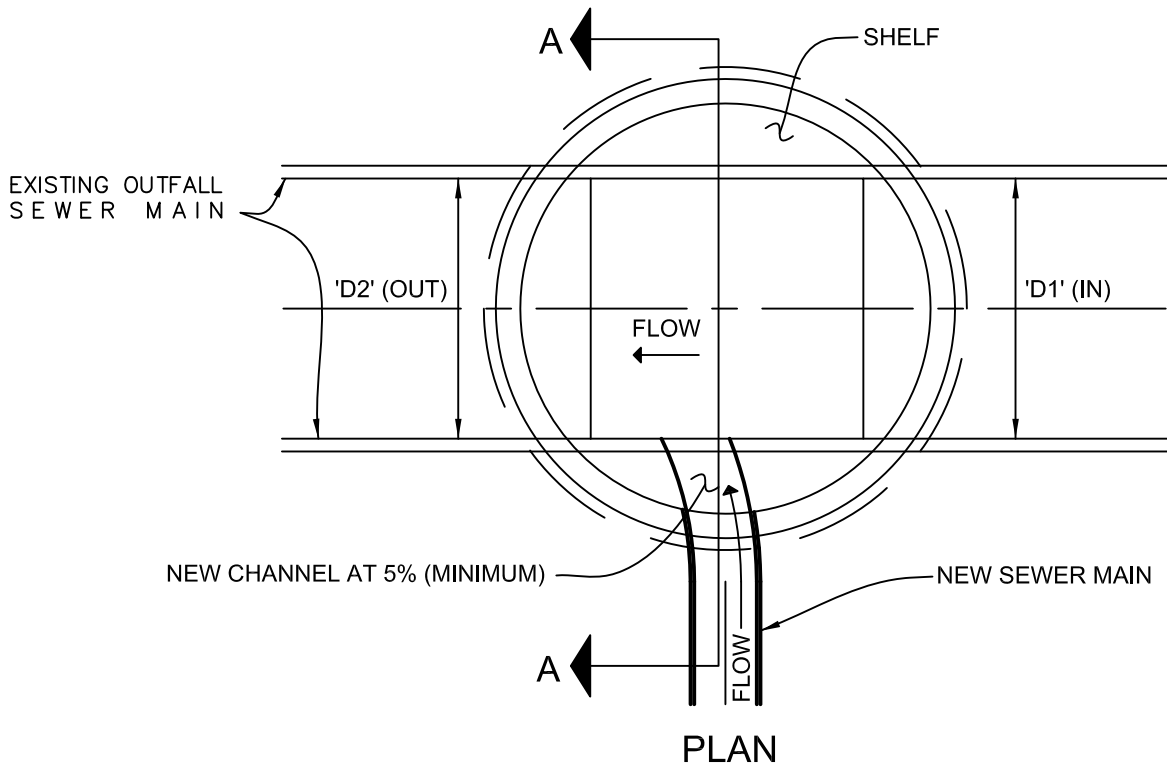

PLAN

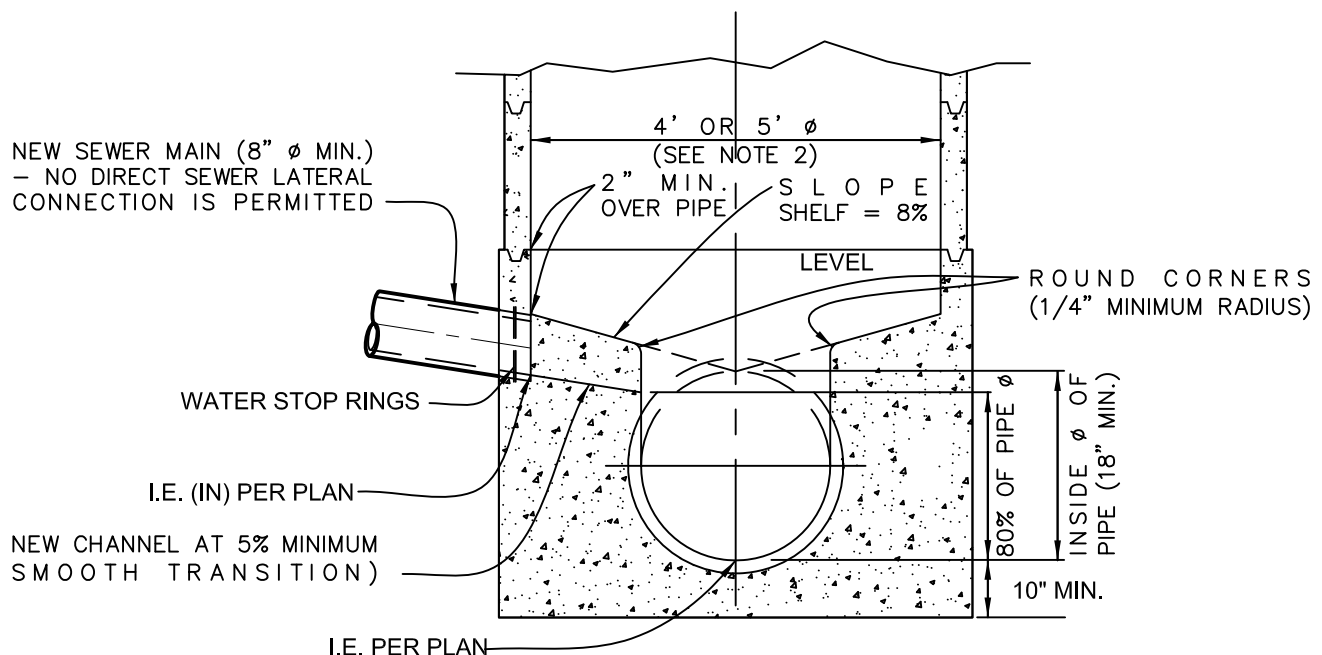

SECTION A-A

NOTES:

1. IF 'D1' ≠ 'D2', MAINTAIN THE LOWEST INVERT ELEVATION AND USE THE LARGER Ø PIPE TO CALCULATE THE INVERT ELEVATION OF THE PROPOSED SEWER MAIN.
2. MANHOLE SHALL BE PER SAN DIEGO REGIONAL STANDARD DRAWINGS SM-01 (48" Ø PRECAST MANHOLE INSTALLATION) OR SM-02 (60" Ø PRECAST MANHOLE INSTALLATION).

LEGEND

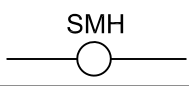

Revision	By	Apprvd	Date	<p>CITY OF VISTA STANDARD DRAWING</p>	
New		TH	07/08/93	<p>OUTFALL AND TRUNKLINE SEWER CONNECTION</p>	<p>CITY ENGINEER, DATE RCE 55075</p>
Updated	TR	SS	04/19/08		<p>DRAWING NUMBER: SWR-32</p>
Updated	TR	GM	01/31/13		

MINIMUM 1.5" AC
OVER 12" CONCRETE

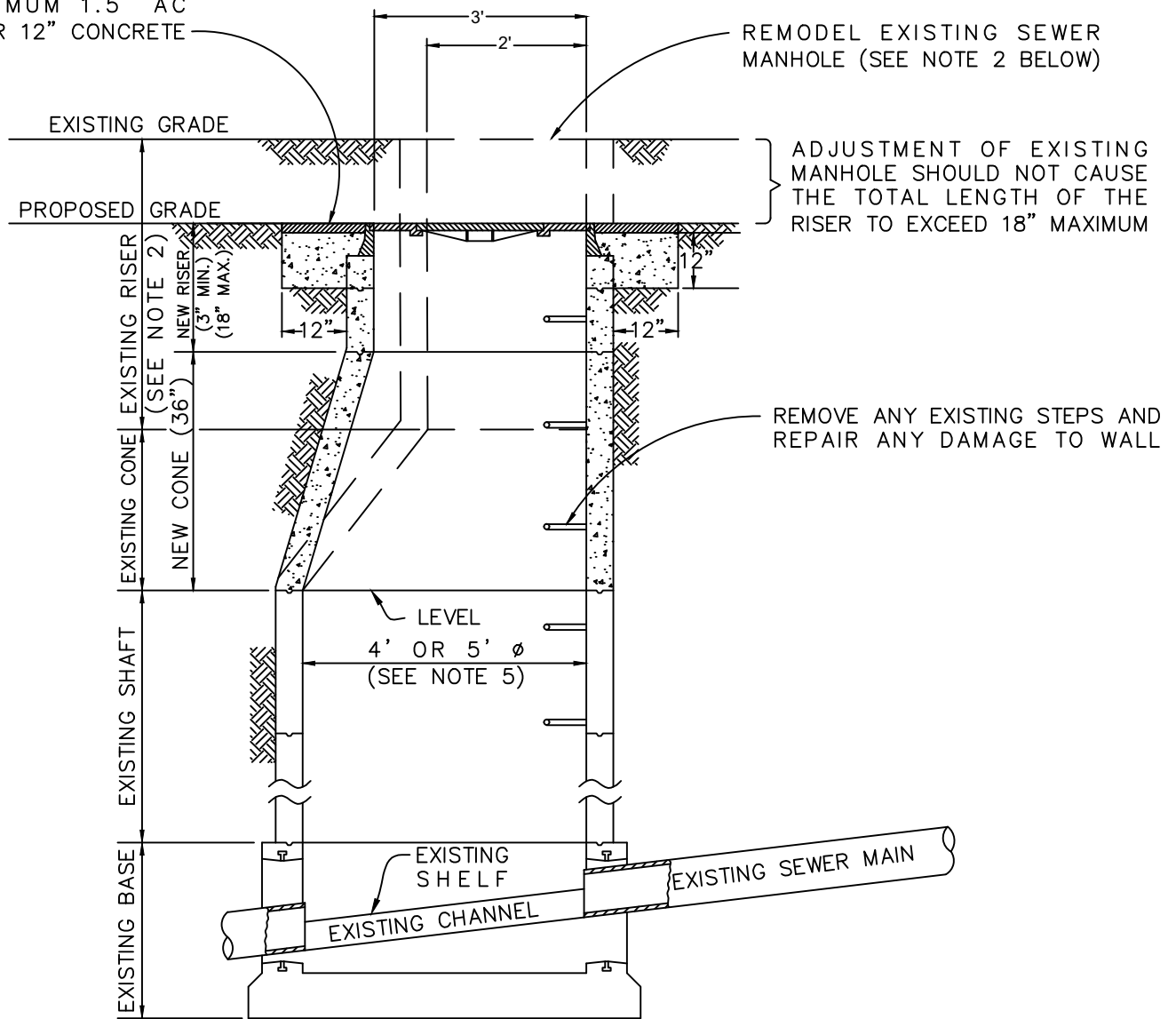

NOTES:

1. SALVAGEABLE MATERIALS SHALL BE DELIVERED TO THE CITY OF VISTA PUBLIC WORKS YARD.
2. REPLACE EXISTING 2' ϕ RISERS, FRAMES, CONES AND COVERS WITH NEW 3' ϕ RISERS, FRAMES, CONES AND COVERS. RECONSTRUCT EXISTING SEWER MANHOLES PER SAN DIEGO REGIONAL STANDARD DRAWINGS:
SM-01 (48" ϕ PRECAST MANHOLE INSTALLATION),
SM-02 (60" ϕ PRECAST MANHOLE INSTALLATION) AND
M-3 (36" MANHOLE FRAME AND TWO CONCENTRIC COVERS HEAVY DUTY).
3. MANHOLE SHAFT AND BENCH, INCLUDING CHANNEL IF PRACTICABLE, SHALL BE REHAB'D WITH MORTAR, EPOXY LINED (MIN. 125-MIL) WITH RAVEN 405 (OR APPROVED EQUAL), AND SPARK TESTED PER GREENBOOK STANDARDS.
4. BYPASS OF SEWER FLOWS REQUIRES A SEPARATE SEWER BYPASS PLAN PER CITY OF VISTA "SEWER BYPASS PUMPING GUIDELINES AND REQUIREMENTS".
5. CONSTRUCT EXISTING SEWER MANHOLES PER SAN DIEGO REGIONAL STANDARD DRAWINGS:
SM-01 (48" ϕ PRECAST MANHOLE INSTALLATION),
SM-02 (60" ϕ PRECAST MANHOLE INSTALLATION)

LEGEND

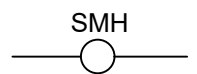

Revision	By	Apprvd	Date
New		TH	07/08/93
Updated	TR	SS	04/19/08
Updated	TR	GM	01/31/13
Updated	SN	KK	05/23/23

CITY OF VISTA
STANDARD DRAWING

**SEWER MANHOLE
RECONSTRUCTION**

CITY ENGINEER, DATE
RCE 55075

DRAWING NUMBER: **SWR-33**

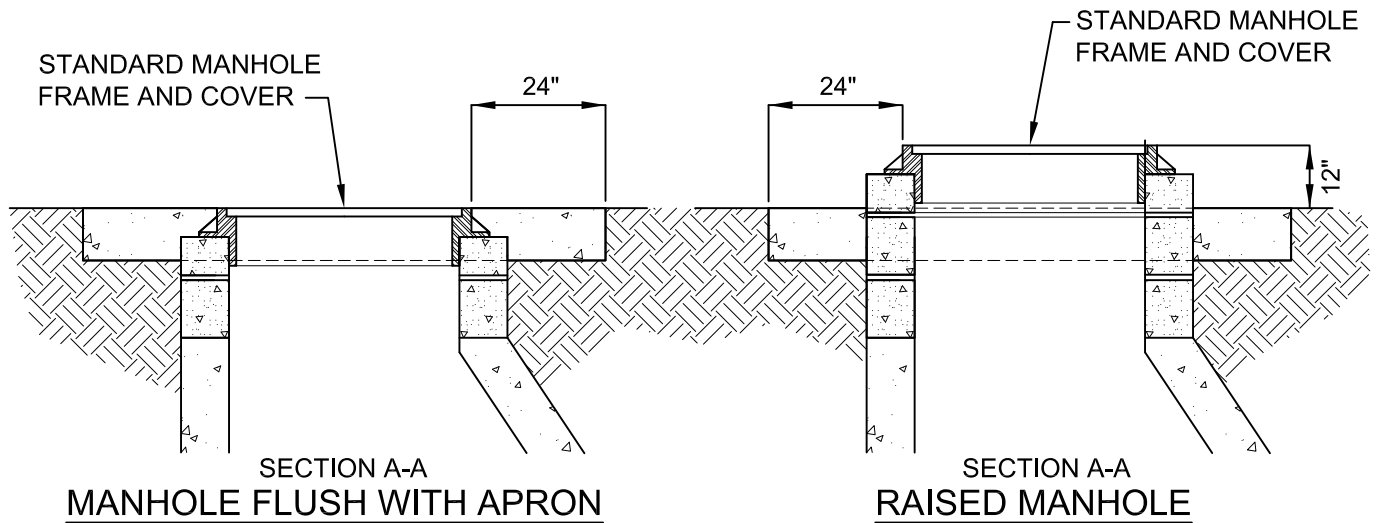
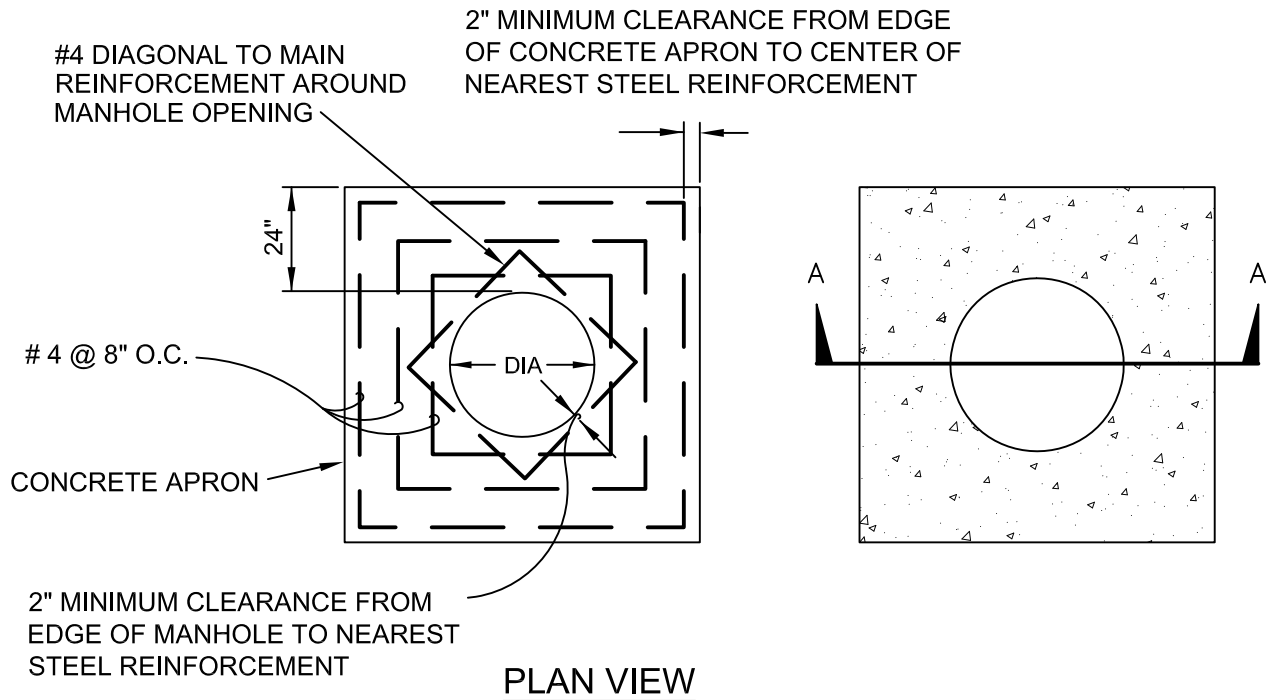

GENERAL NOTES:

1. THE 6" THICK CONCRETE APRON SHOULD BE CAST-IN-PLACE CONCRETE (520-C-2500).
2. PROVIDE A MINIMUM OF 2" OF CONCRETE COVER FOR ALL REINFORCEMENT STEEL.
3. STEEL REINFORCEMENT SHALL MEET ASTM C-478 REQUIREMENTS.
4. NO. 4 REBARS SPACED EQUALLY MAY BE LAP TIED OR SQUARE HOOPS.

Revision	By	Apprvd	Date
New	GL	SS	03/01/12

CITY OF VISTA
STANDARD DRAWING

**CONCRETE APRON FOR SEWER
MANHOLE (UNTRAVELED AREAS)**

[Signature]

CITY ENGINEER DATE
RCE 55075

DRAWING NUMBER: **SWR-34**

SURFACE IMPROVEMENTS

**THIS SHEET INTENTIONALLY
LEFT BLANK**

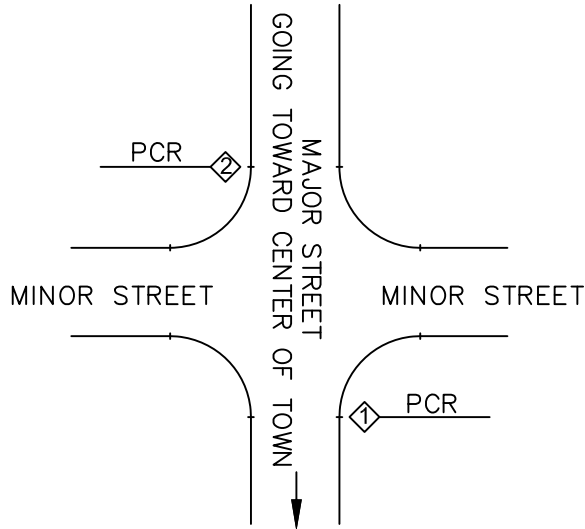

STREET NAME SIGN LOCATION

(NUMBERS INDICATE PRIORITY OF LOCATION SELECTION)

CURB AND SIDEWALK	SIDEWALK WIDTH	SETBACK
CONTIGUOUS	EQUAL TO OR LESS THAN 6'	SIDEWALK WIDTH + 0.5' (4' MINIMUM)
CONTIGUOUS	GREATER THAN 6'	1.5'
SEPARATE	4' MINIMUM	PARKWAY WIDTH - 1'

NOTES:

1. HOLE SPACING SHALL MATCH THE HOLES IN THE EXTRUDED BLADES.
2. BRACKET TO BE DIE CAST ALUMINUM.
3. ALL ATTACHING SCREWS SHALL BE STAINLESS STEEL VANDAL PROOF TYPE.

Revision	By	Apprvd	Date	CITY OF VISTA STANDARD DRAWING	
Updated	TR	SS	03/01/12		
Updated	GL	HH	05/07/14	PUBLIC STREET NAME SIGN DETAILS (FOR NON-SIGNALIZED INTERSECTIONS)	CITY ENGINEER, DATE RCE 55075
					DRAWING NUMBER: SRF-01A

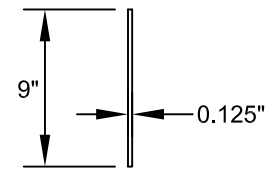
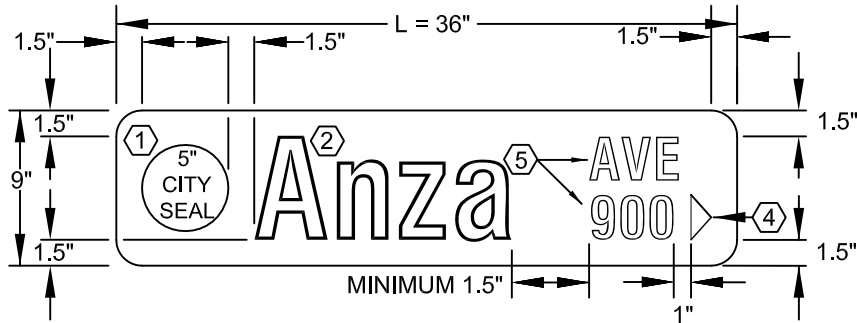

SIGN BLADE SECTION

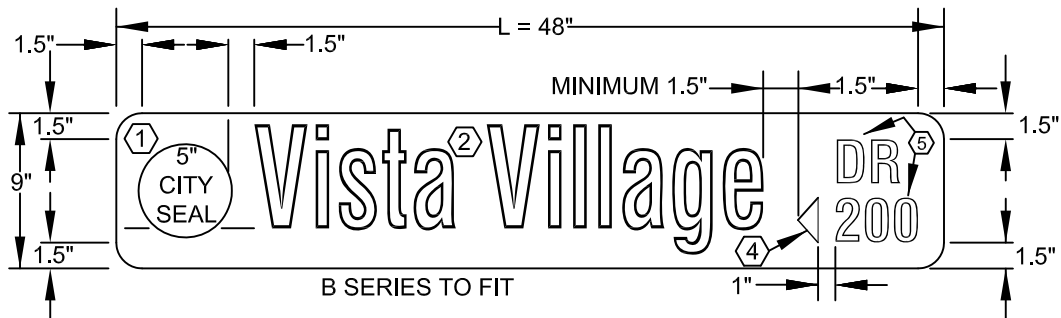

* SEE NOTE ③ BELOW

TYPICAL PUBLIC STREET NAME SIGN LAYOUT

TYPICAL LAYOUT OF LEGEND ON VARIABLE LENGTH SIGN BLADE OF EXTRUDED ALUMINUM WITH (DIAMOND GRADE 3) REVERSE SCREENED REFLECTIVE SHEETING WITH DIAMOND GRADE WHITE LETTERS.

- ① REFLECTIVE 5" CITY SEAL ON THE LEFT SIDE OF ALL 9' HIGH PUBLIC STREET NAME SIGNS.
- ② 6" FOR UPPER CASE LETTERING AND 4.5" FOR LOWERCASE LETTERING (C SERIES). SUFFIX/BLK # 2.5" C SERIES.
- ③ * 2.5" E.D. FOR HANGING LEGEND; 6" FOR UPPERCASE LETTERING AND 4.5" FOR LOWERCASE LETTERING (C SERIES) (B TO FIT). SUFFIX/BLK# 2.5" C SERIES.
- ④ ARROW TO BE 1.17" WIDE AND 2.61" HIGH.
- ⑤ PREFERRED ABBREVIATIONS:

AVENUE:	AV. OR AVE.	DRIVE:	DR.	PARK:	PK.	STREET:	ST.
BOULEVARD:	BL. OR BLVD.	HEIGHTS:	HTS.	PARKWAY:	PKY. OR PKWY.	TERRACE:	TER.
CANYON:	CYN.	HIGHWAY:	HWY.	PLACE:	PL.	TRAIL:	TR.
CIRCLE:	CIR.	LANE:	LN.	ROAD:	RD.	WAY:	WY. OR WAY

NOTE: SEE THE CITY OF VISTA TRAFFIC (TRF) STANDARD DRAWING TRF-03 FOR THE DESIGN CRITERIA FOR STREET NAME SIGNS ATTACHED TO THE TRAFFIC SIGNAL MAST ARM AT SIGNALIZED INTERSECTIONS.

Revision	By	Apprvd	Date	CITY OF VISTA STANDARD DRAWING	
Updated	TR	SS	03/01/12		
				PUBLIC STREET NAME SIGN DETAILS (FOR NON-SIGNALIZED INTERSECTIONS)	CITY ENGINEER, DATE RCE 55075
					DRAWING NUMBER: SRF-01B

Brass LN
100 ▶

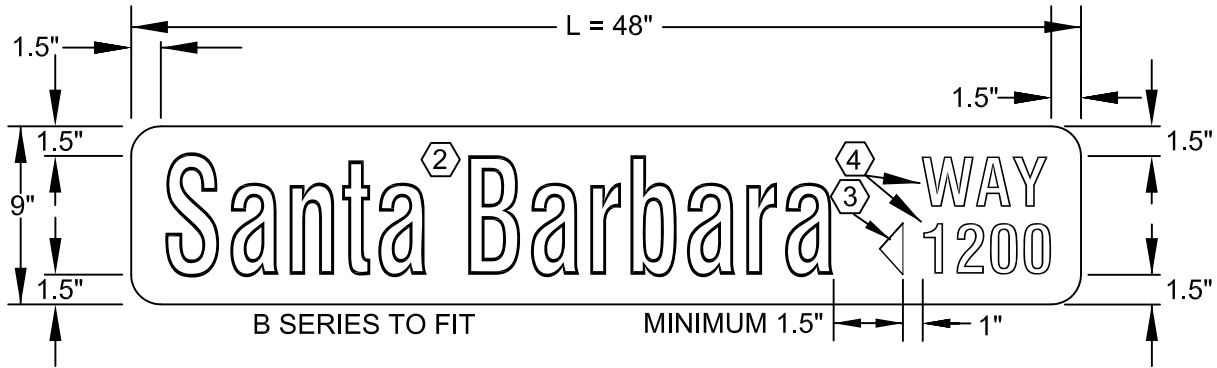
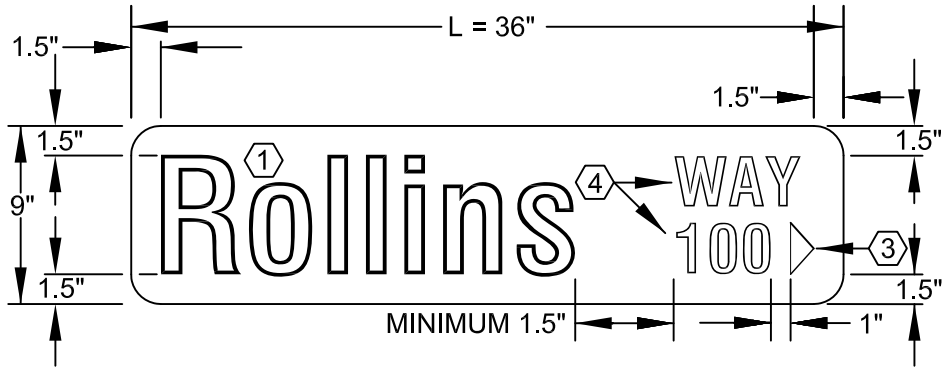

TYPICAL PRIVATE STREET NAME SIGN LAYOUT

TYPICAL LAYOUT OF LEGEND ON VARIABLE LENGTH SIGN BLADE OF EXTRUDED ALUMINUM WITH (DIAMOND GRADE 3) REVERSE SCREENED REFLECTIVE SHEETING WITH DIAMOND GRADE WHITE LETTERS.

- ① 6" FOR UPPERCASE LETTERING AND 4.5" FOR LOWERCASE LETTERING (C SERIES). SUFFIX/BLK#" 2.5" C SERIES.
- ② 6" FOR UPPER CASE LETTERING AND 4.5" FOR LOWERCASE LETTERING (C SERIES) (B TO FIT). SUFFIX/BLK#" 2.5" C SERIES.
- ③ ARROW TO BE 1.17" WIDE AND 2.61" HIGH.
- ④ PREFERRED ABBREVIATIONS:

AVENUE:	AV. OR AVE.	DRIVE:	DR.	PARK:	PK.	STREET:	ST.
BOULEVARD:	BL. OR BLVD.	HEIGHTS:	HTS.	PARKWAY:	PKY. OR PKWY.	TERRACE:	TER.
CANYON:	CYN.	HIGHWAY:	HWY.	PLACE:	PL.	TRAIL:	TR.
CIRCLE:	CIR.	LANE:	LN.	ROAD:	RD.	WAY:	WY.

Revision	By	Apprvd	Date	CITY OF VISTA STANDARD DRAWING	
Updated	TR	SS	03/01/12		
				PUBLIC STREET NAME SIGN DETAILS (FOR NON-SIGNALIZED INTERSECTIONS)	CITY ENGINEER, DATE RCE 55075
					DRAWING NUMBER: SRF-01C

THIS SHEET
INTENTIONALLY LEFT BLANK

Revision	By	Apprvd	Date	CITY OF VISTA STANDARD DRAWING			
						CITY ENGINEER, RCE 55075	DATE
						DRAWING NUMBER:	SRF-02

PUBLIC STREET DESIGN CRITERIA

STREET CLASS	6-LANE PRIME ARTERIAL (DIVIDED)	6-LANE URBAN ARTERIAL (DIVIDED)	4-LANE MAJOR ARTERIAL (DIVIDED)	4-LANE COLLECTOR (UNDIVIDED)	2-LANE COLLECTOR WITH TWLTL (22)	2-LANE COLLECTOR	2-LANE LITE COLLECTOR/ LOCAL STREET	CUL-DE-SAC STREET	HILLSIDE STREET	ALLEY	SEMI-RURAL ROAD
STREET CRITERIA	48,000	40,000	32,000	21,000	12,000	1,500	N/A	N/A	N/A	N/A	N/A
ADT (LOS "C")	54,000	45,000	36,000	24,500	13,000	4,500	N/A	N/A	N/A	N/A	N/A
ADT (LOS "D")	60,000	50,000	40,000	30,000	15,000	7,000	300	300	300	N/A	7,000
ADT (LOS "E")	55 MPH (1)	50 MPH (1)	45 MPH	45 MPH	35 MPH	30 MPH	25 MPH	25 MPH	20 MPH	N/A	20 MPH
DESIGN SPEED	126 FT (2)	110 FT (2)	100 FT (2)	84 FT (2)	68 FT (2)	70 FT (15) (60 FT)	60 FT	56 FT	40 FT	20 FT (20)	60 FT
R.O.W. WIDTH	106 FT (2)	94 FT (2)	80 FT (2)	64 FT (2)	48 FT (2)	50 FT (15) (40 FT)	40 FT	36 FT	28 FT	20 FT	28 FT
CURB-TO-CURB WIDTH (MEDIAN WIDTH OR N/A)	5-FEET (MIN.)	5-FEET (MIN.)	5-FEET (MIN.)	5-FEET (MIN.)	5-FEET (MIN.)	5-FEET (MIN.)	5-FEET (MIN.)	5-FEET (MIN.)	AS REQUIRED	AS REQUIRED	AS REQUIRED
SIDEWALK WIDTHS (EXCLUDING CURB)	9.0	9.0	8.5	8.0	8.0	6.0	6.0	6.0	6.0	6.0	6.0
MINIMUM TRAFFIC INDEX	$\frac{6''}{8''}$ AC AB	$\frac{6''}{8''}$ AC AB	$\frac{5''}{8''}$ AC AB	$\frac{4''}{8''}$ AC AB	$\frac{4''}{8''}$ AC AB	$\frac{4''}{8''}$ AC AB	$\frac{4''}{8''}$ AC AB	$\frac{4''}{8''}$ AC AB	$\frac{4''}{8''}$ AC AB	$\frac{4''}{8''}$ AC AB	$\frac{4''}{8''}$ AC AB
MIN. STRUCTURAL SECTION (3)	2,200 FT	2,200 FT	1,400 FT	1,100 FT	600 FT	425 FT	300 FT	300 FT	150 FT (18)	100 FT	150 FT
MIN. HORIZONTAL RADIUS (4)	200 FT	200 FT	150 FT	100 FT	100 FT	100 FT	50 FT	50 FT	N/A	50 FT	50 FT
MIN. "RECOVERY" TANGENT	35 FT	35 FT	35 FT	35 FT	35 FT	35 FT	25 FT	25 FT	25 FT	10 FT	25 FT
CURB RETURN RADIUS (5)	10°	10°	10°	10°	10°	10°	10°	10°	10°	0°	10°
MAXIMUM INTERSECTION SKEW	2,600 FT (1,300 FT)	2,600 FT (1,300 FT)	1,200 FT (600 FT)	600 FT (300 FT)	600 FT (300 FT)	300 FT (300 FT)	200 FT (150 FT)	200 FT (150 FT)	150 FT	N/A	N/A
MIN. INTERSECTION SPACING (OFFSET "Ts")	600 FT	600 FT	500 FT	N/A	N/A	N/A	N/A	N/A	N/A	N/A	N/A
MIN. MEDIAN CURB OPENING SPACING	100 FT	100 FT	100 FT	100 FT	50 FT	50 FT	25 FT	25 FT	25 FT	N/A	N/A
MIN. INTERSECTION TANGENT (6)	7%	7%	7%	8%	10%	12%	12%	12%	12%	12%	13%
MAXIMUM GRADE (7)	0.5%	0.5%	0.5%	0.5%	0.5%	0.5%	0.5%	0.5%	0.5%	0.5%	0.5%
MINIMUM GRADE											

Revision	By	Apprvd	Date
New		GR	03/05/85
Updated	TR	SS	03/01/12

CITY OF VISTA
STANDARD DRAWING

PUBLIC AND PRIVATE STREET DESIGN CRITERIA (SHT 1 OF 4)



CITY ENGINEER, DATE
RCE 55075

DRAWING NUMBER: **SRF-03A**

PUBLIC STREET DESIGN CRITERIA

STREET CLASS	6-LANE PRIME ARTERIAL (DIVIDED)	6-LANE URBAN ARTERIAL (DIVIDED)	4-LANE MAJOR ARTERIAL (DIVIDED)	4-LANE COLLECTOR (UNDIVIDED)	2-LANE COLLECTOR WITH TWLTL (22)	2-LANE COLLECTOR	2-LANE LOCAL STREET	CUL-DE-SAC STREET	HILLSIDE STREET	ALLEY	SEMI-RURAL ROAD
VERTICAL CURVE (8) "K" SAG "K" CREST	120-160 190-310	120-160 190-310	90-110 110-160	60-70 60-80	40 30	40 30	30 20	20 10	30 20	N/A	N/A
MAXIMUM SUPER ELEVATION (9)	4%	4%	4%	4%	2%	-2% (16)	-2% (16)	-2% (16)	-2% (16)	-2% (16)	-2% (16)
LIGHTING AT: INTERSECTION / NON-INTERSECTION (10)	116 WATT LED 116 WATT LED	116 WATT LED 116 WATT LED	116 WATT LED 92 WATT LED	92 WATT LED 92 WATT LED	92 WATT LED 37 WATT LED	92 WATT LED 37 WATT LED	92 WATT LED 37 WATT LED	37 WATT LED 37 WATT LED	37 WATT LED 37 WATT LED	N/A	N/A
STOPPING SIGHT DISTANCE	525 FT - 650 FT	525 FT - 650 FT	400 FT - 475 FT	350 FT - 400 FT	275 FT - 325 FT	175 FT - 225 FT	150 FT - 200 FT	150 FT	125 FT	325 FT	150 FT
DRIVEWAY ACCESS (11)	NONE (12)	NONE (12)	NONE (12)	NONE (12)	NONE (12)	NONE (12)	OK	OK	OK	OK	OK
DRIVEWAY / INTERSECTION SPACING (13)	300 FT	300 FT	200 FT	200 FT	100 FT	100 FT	50 FT	N/A	N/A	N/A	N/A
DRIVEWAY TO DRIVEWAY SEPARATION	250 FT	250 FT	250 FT	175 FT	50 FT	50 FT	50 FT	25 FT	50 FT	N/A	N/A
ON-STREET PARKING	NONE	NONE	NONE	NONE	OK (14)	OK (14)	OK (14)	NONE	(19)	NONE	NONE

Revision	By	Apprvd	Date	CITY OF VISTA STANDARD DRAWING			 CITY ENGINEER, DATE RCE 55075
New		GR	03/05/85				
Updated	TR	SS	03/01/12	PUBLIC AND PRIVATE STREET DESIGN CRITERIA (SHT 2 OF 4)			DRAWING NUMBER: SRF-03B

NOTES:

- (1) DESIGN SPEED FOR PRIME ARTERIALS MAYBE REDUCED IN URBAN AREAS AT THE DISCRETION OF THE CITY ENGINEER.
- (2) RIGHT-OF-WAY AND CURB-TO-CURB DISTANCE MAYBE INCREASED TO PROVIDE FOR SPECIAL ROADWAY GEOMETRICS AT ARTERIAL / ARTERIAL INTERSECTIONS (e.g. DUAL LEFT TURN POCKETS OR DEDICATED, RIGHT TURN ONLY ANCILLARY LANES).
- (3) ACTUAL STRUCTURAL SECTIONS TO BE DETERMINED BY GEOTECHNICAL ENGINEER'S TESTING OF THE SUBGRADE AND RECOMMENDATIONS.
- (4) SUPER ELEVATION AND UPGRADED ROADWAY DRAINAGE MAYBE USED TO REDUCE THESE MINIMUMS.
- (5) AT THE INTERSECTION OF TWO DISSIMILARLY CLASSIFIED STREETS, THE LARGER OF THE TWO RADII SHALL BE USED. ALL RADII ARE MEASURED AT CURB FACE.
- (6) USED WHEN APPROACHING MAJOR SIGNALIZED INTERSECTIONS (EXISTING OR PLANNED), OR TERMINUS OF STREET. DISTANCE IS MEASURED FROM THE P.C.R. MAYBE REDUCED ONLY WITH PERMISSION OF THE CITY ENGINEER.
- (7) MAYBE INCREASED UP AN ADDITIONAL 2% FOR SHORT DISTANCES IN MOUNTAINOUS TERRAIN WITH APPROVAL OF THE CITY ENGINEER. THE MAXIMUM GRADE THROUGH AN INTERSECTION SHALL NOT EXCEED 5%.
- (8) THE AASHTO "COMFORT CURVE" FOR SAG CURVE CONDITIONS, $L = A(V \text{ SQUARED})/46.5$, IS AN ACCEPTABLE ALTERNATIVE IF ADEQUATE SUPPLEMENTAL STREET ILLUMINATION IS PROVIDED.
- (9) A 0.04 (4.0%) MAXIMUM "SUPER" IS TO BE EXCEEDED ONLY WITH PERMISSION OF THE CITY ENGINEER. AN ABSOLUTE MAXIMUM OF 0.06 (6.0%) SHOULD NEVER BE EXCEEDED IN URBAN AREAS OR ON ROUTES WITH SIGNIFICANT TRUCK TRAFFIC IN THE TRAFFIC STREAM.
- (10) AT THE INTERSECTION OF TWO DISSIMILARLY CLASSIFIED STREET, THE LUMINARY REQUIREMENTS FOR THE HIGHER CLASSIFIED STREET SHALL BE USED. AT SIGNALIZED INTERSECTIONS, LIGHTING SHALL BE DESIGNED TO PROVIDE AN ILLUMINATION LEVEL OF 0.6 FOOT-CANDLE AT THE INTERSECTION OF THE STREET CENTERLINES. ALL STREET LIGHTS SHALL BE LIGHT EMITTING DIODE (BetaLED). SEE CITY OF VISTA STANDARD DRAWING ELE-1A FOR STREETLIGHT SPACING CRITERIA.
- (11) MAXIMUM DRIVEWAY WIDTH IS THIRTY FEET (30'). AN ALTERNATE MAXIMUM DRIVEWAY WIDTH OF THIRTY-SIX FEET (36') IS ACCEPTABLE IF THERE IS JOINT ACCESS BETWEEN ADJACENT PROPERTIES. NEW DRIVEWAYS IN COMMERCIALY AND INDUSTRIALLY ZONED AREAS SHALL BE THE RADIUS TYPE PER THE CITY'S STANDARD DRAWING HANDOUT.
- (12) NONE IF OTHER AVAILABLE. 24' TO 30' (36' FOR JOINT ACCESS) DRIVEWAYS ONLY WHEN ABSOLUTELY NECESSARY. DRIVEWAY GEOMETRICS MAYBE REQUIRED TO RESTRICT TURNS TO RIGHT TURN IN OR RIGHT TURN OUT ON AN AUXILIARY LANE. A 20' MINIMUM THROAT DISTANCE (MEASURED FROM THE ULTIMATE RIGHT-OF-WAY LINE) IS REQUIRED AS PART OF ON-SITE PARKING LOT DESIGN.
- (13) DISTANCE IS MEASURED FROM P.C.R. TO NEAR SIDE OF THE DRIVEWAY. APPROVAL OF DRIVEWAYS WITHIN THIS SEPARATION MAYBE CONTINGENT UPON DRIVEWAY GEOMETRICS THAT ALLOW ONLY RIGHT TURNS IN OR RIGHT TURNS OUT ON AN AUXILIARY LANE, AND / OR RECIPROCAL ACCESS AGREEMENTS WITH THE ADJACENT PROPERTY OWNER(S).
- (14) MAYBE RESTRICTED. NEW DRIVEWAYS IN COMMERCIALY AND INDUSTRIALLY ZONED AREAS SHALL BE THE RADIUS TYPE PER THE CITY'S STANDARD DRAWING HANDOUT.
- (15) FOR STREETS DESIGNED WITH A CENTER TURN LANE.
- (16) SUPER ELEVATION IS NOT RECOMMENDED ON INDUSTRIAL, LOCAL, CUL-DE-SACS, HILLSIDE STREETS, RURAL ROADS OR ALLEYS.
- (17) A 14% MAXIMUM GRADE (15% FOR RURAL ROADS) WITH REINFORCED CONCRETE AS A STREET SURFACE INSTEAD OF ASPHALT CONCRETE.
- (18) SUBJECT TO APPROVAL BY CITY ENGINEER.
- (19) PARKING PERMITTED ON ONE SIDE OF STREET ONLY.
- (20) MAY VARY.
- (21) WITH POPOUTS @ 30 FEET.
- (22) TWO WAY LEFT TURN (IN STRIPED CENTER MEDIAN)

Revision	By	Apprvd	Date	CITY OF VISTA STANDARD DRAWING	
New		GR	03/05/85		
Updated	TR	SS	03/01/12	RCE 55075	
				DRAWING NUMBER: SRF-03C	

PRIVATE STREET DESIGN CRITERIA

CASE NUMBER	LOT SIZE	ROAD EASEMENT WIDTH	PUBLIC UTILITY EASEMENT WIDTH	PAVED WIDTH	MINIMUM TRAFFIC INDEX	CURB & GUTTER REQUIRED?	5-FOOT SIDEWALK REQUIRED?	SINGLE LOADED	GRADED SHOULDER REQUIRED	ZONE
1	LESS THAN 0.5 ACRE & LESS THAN 600 FT IN LENGTH	46 FEET	5 FEET (EACH SIDE)	36 FEET	5.5	YES	YES	YES	5 FEET (EACH SIDE) (P.U.E.)	R-1
2	LESS THAN 0.5 ACRE & GREATER THAN 600 FT IN LENGTH	50 FEET	5 FEET (EACH SIDE)	40 FEET	5.5	YES	YES	YES	5 FEET (EACH SIDE) (P.U.E.)	R-1
3	LESS THAN 0.5 ACRE & SINGLE LOADED	40 FEET	5 FEET (EACH SIDE)	32 FEET	5.5	YES GUTTER ON ONE SIDE	YES ONE SIDE	YES	5 FEET (EACH SIDE) (P.U.E.)	E
4	0.05 ACRE AND GREATER	30 FEET	AS REQUIRED	24 FEET	5.0	MOUNTABLE PCC OR AC CURB	NO	N/A	3 FEET AND NO PARKING	A

Revision	By	Apprvd	Date
New		GR	03/05/85
Updated	TR	SS	03/01/12

CITY OF VISTA
 STANDARD DRAWING

PUBLIC AND PRIVATE STREET DESIGN CRITERIA (SHT 4 OF 4)

 CITY ENGINEER, DATE
 RCE 55075

 DRAWING NUMBER: **SRF-03D**

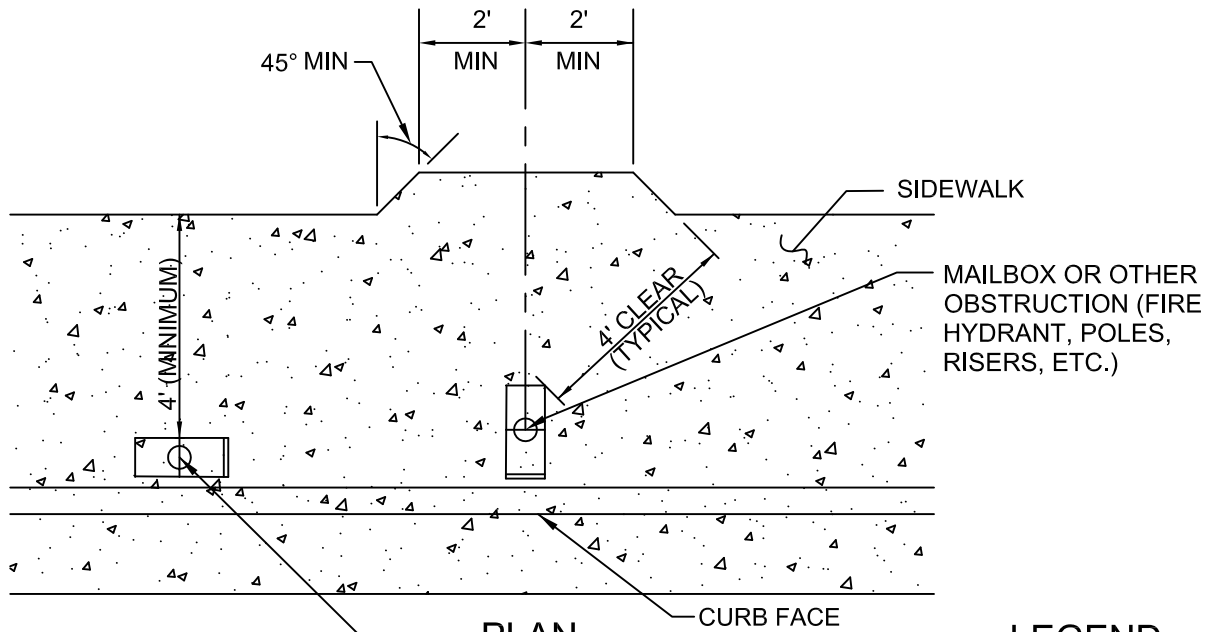

MAILBOX CAN BE SET SIDWAYS, WITH OPENING INLINE WITH ROADWAY TRAVEL DIRECTION, IN ORDER TO MAINTAIN A 48" PATH OF TRAVEL. CAN BE UTILIZED ONLY IF RIGHT-OF-WAY OR OTHER OBSTRUCTION LIMITS SIDEWALK WIDTH

PLAN
NO SCALE

LEGEND

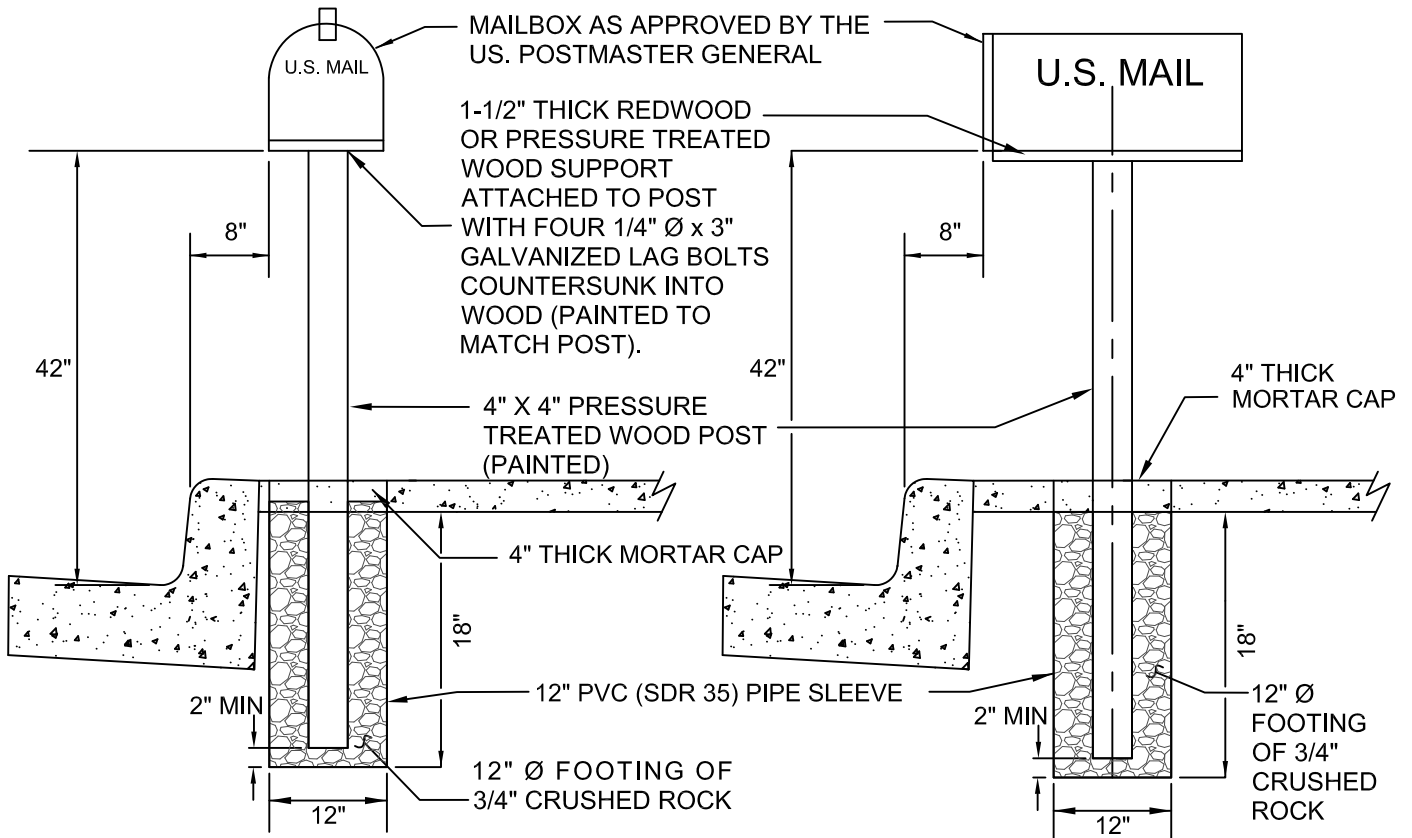

ELEVATION
NO SCALE

Revision	By	Apprvd	Date
New		TH	08/23/90
Updated	TR	GM	02/11/13
Updated	GL	HH	05/07/14

CITY OF VISTA
STANDARD DRAWING

[Signature]

**MAILBOX INSTALLATION
IN SIDEWALK**

CITY ENGINEER, DATE
RCE 55075

DRAWING NUMBER: **SRF-04**

TAPERED DOWN CURB FACE
UNLESS JOINING OPTIONAL
ON-SITE CURB (TYPICAL)

DRIVEWAY WIDTH AS
SHOWN ON PLANS
(24' MINIMUM) *

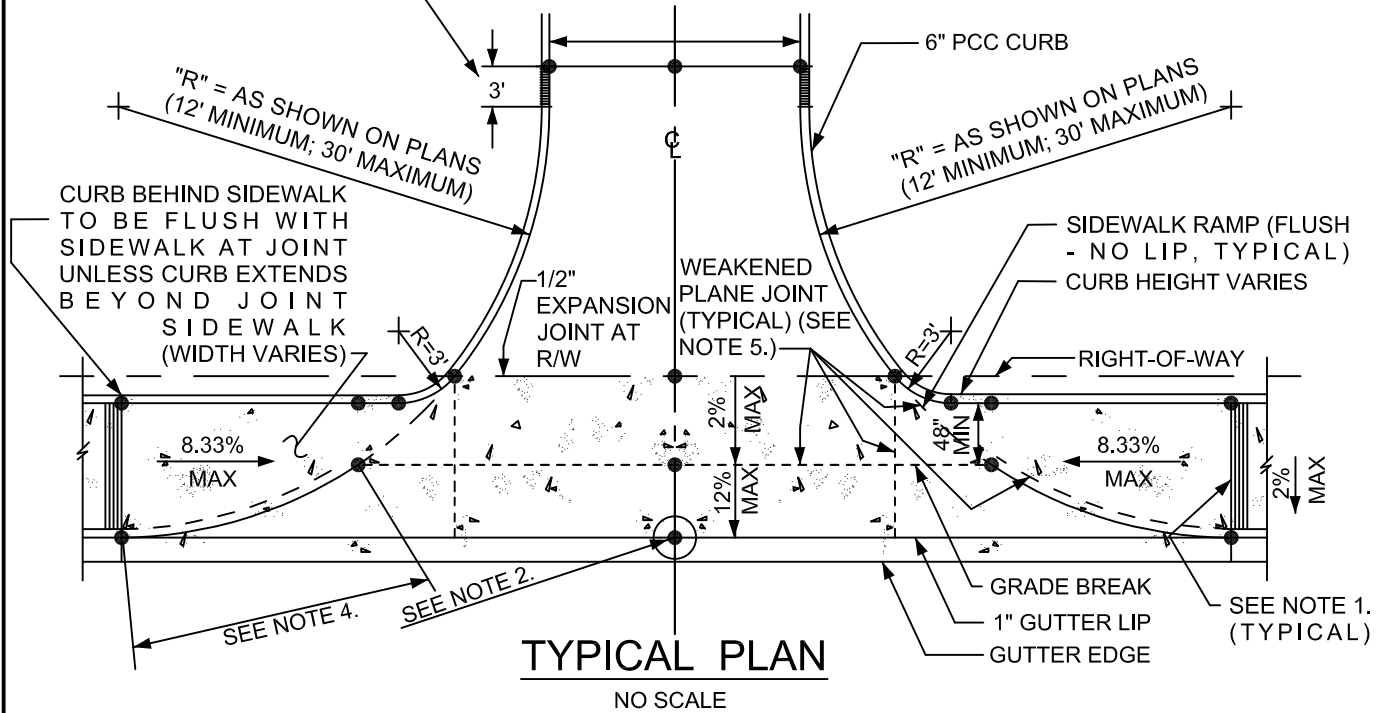

TYPICAL PLAN

NO SCALE

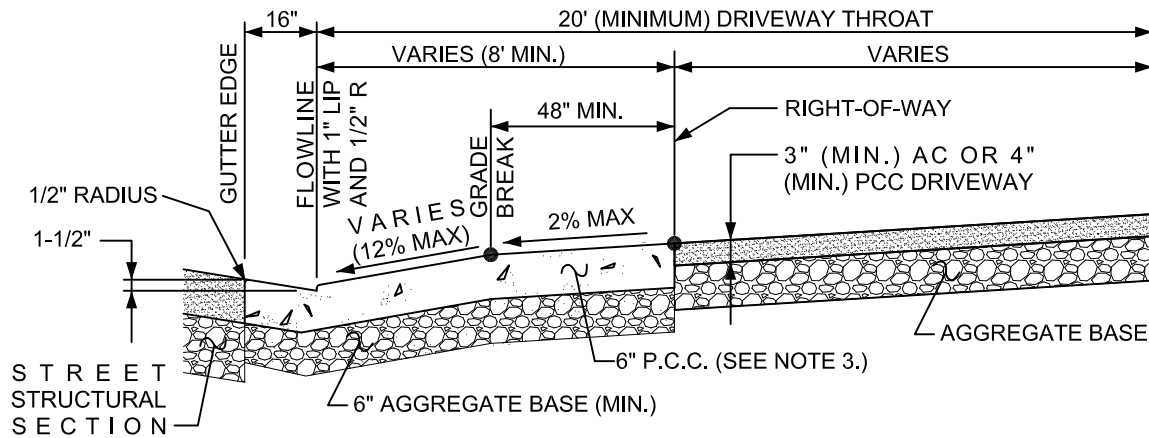

CENTERLINE CROSS SECTION

NO SCALE

NOTES:

1. ALLEY TYPE DRIVEWAY SHALL BE POURED MONOLITHICALLY (INCLUDING RETAINING CURBS). INSTALL A 1/2" EXPANSION JOINT BETWEEN RAMPS AND SIDEWALKS AND IN THE DRIVEWAY AT THE R/W. THE SIDEWALK ADJACENT TO THE RAMPS SHALL HAVE A 12" WIDE BORDER WITH 1/8" RADIUS LINES SCORED 1/4" DEEP. THE SPACING SHALL BE APPROXIMATELY 3/4" O/C.
2. ● = THESE TYPICAL ELEVATIONS SHALL BE SHOWN ON PLANS (I.E.: TOP OF CURB, FLOW LINE AND FINISHED SURFACE).
3. CONCRETE MIX DESIGN SHALL BE 560-C-3250 (6 SACK). NO CONCRETE SHALL BE PLACED UNTIL SUBGRADE, BASE AND FORMS HAVE BEEN INSPECTED BY THE CITY.
4. TRANSITION FROM FULL HEIGHT CURB TO FLUSH. PROVIDE WEAKENED PLANE JOINT 6" BEHIND CURB AND AT CURB LINE WHERE CURB IS FLUSH.
5. WEAKENED PLANE JOINTS SHALL BE INSTALLED ON BOTH SIDES OF THE DRIVEWAY AND AT TEN FOOT (10') INTERVALS (MAXIMUM) (OPTIONAL AT GRADE BREAK). SEE SDRSD G-2 AND G-10 FOR CURB AND JOINT DETAILS.

* OR AS REQUIRED BY THE CITY ENGINEER

Revision	By	Apprvd	Date	CITY OF VISTA STANDARD DRAWING	
New		TH	06/26/91		
Updated	TR	GM	02/11/13	ALLEY TYPE DRIVEWAY	CITY ENGINEER, DATE RCE 55075
					DRAWING NUMBER: SRF-05A

DRIVEWAY SELECTION TABLE

TYPE OF DRIVEWAY APPROACH	2-WAY DAILY DRIVEWAY VOLUME
SDRSD G-14 & G-26	0 - 200
VISTA DWG SRF-05A & -05B	200 - 2500
STANDARD INTERSECTION	2500 +

DRIVEWAY DIMENSIONS

RADIUS R	X	Y
10'	9.00'	9.95'
15'	13.51'	14.93'
20'	18.01'	19.90'
25'	22.51'	24.88'
30'	27.01'	29.85'

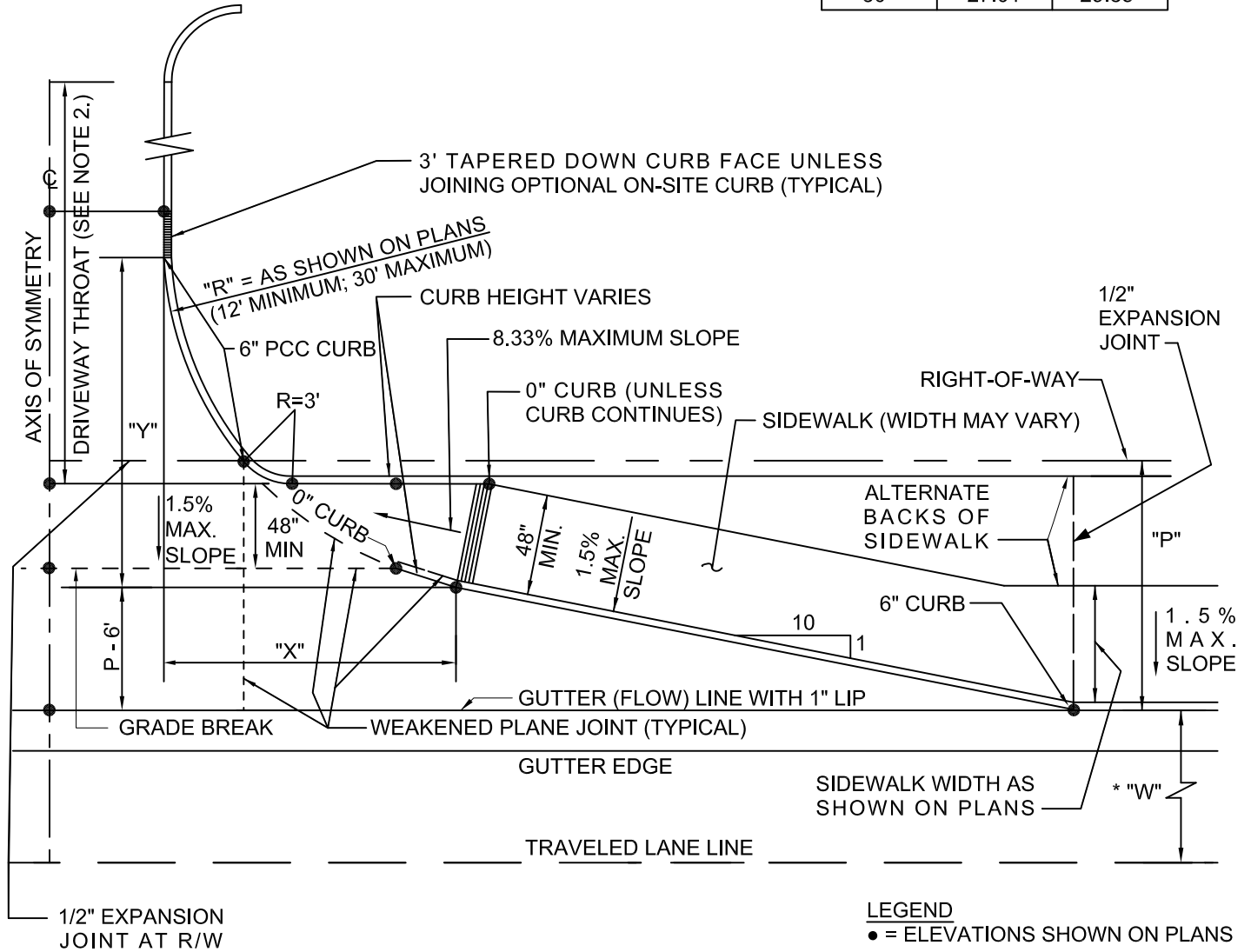

LEGEND
 • = ELEVATIONS SHOWN ON PLANS

NOTES:

- "P" = PARKWAY WIDTH
- P - 6' = OFFSET
- * = USE OFFSET TRANSITION WHEN "W" < 18 FEET AND "P" = OR > 10 FEET.
- 1. AUXILIARY 12' WIDE RIGHT TURN LANE IN STREET SHALL BE REQUIRED WHEN RIGHT TURN MOVEMENT EXCEEDS 125 VEHICLES PER HOUR. MINIMUM 250 FOOT LENGTH INCLUDING A 90 FOOT BAY TAPER TRANSITION.
- 2. DRIVEWAY THROAT OR RESERVOIR LENGTH SHALL BE 20' MINIMUM TO 150' MAXIMUM. THROAT AREA SHALL BE CLEAR OF CROSS TRAFFIC. THROAT LENGTH TO BE 20' PER 1000 ADT AND APPROVED BY THE CITY ENGINEER.

Revision	By	Apprvd	Date
New		TH	06/26/91
Updated	TR	GM	02/11/13

CITY OF VISTA
STANDARD DRAWING

ALLEY TYPE DRIVEWAY

[Signature]
CITY ENGINEER, DATE
RCE 55075

DRAWING NUMBER: **SRF-05B**

PUBLIC STREET AND UTILITY EASEMENT FOR STREET, SIDEWALK, STREET LIGHTS, FIRE HYDRANTS, ELECTRIC, TELEPHONE & CABLE TV AS NEEDED

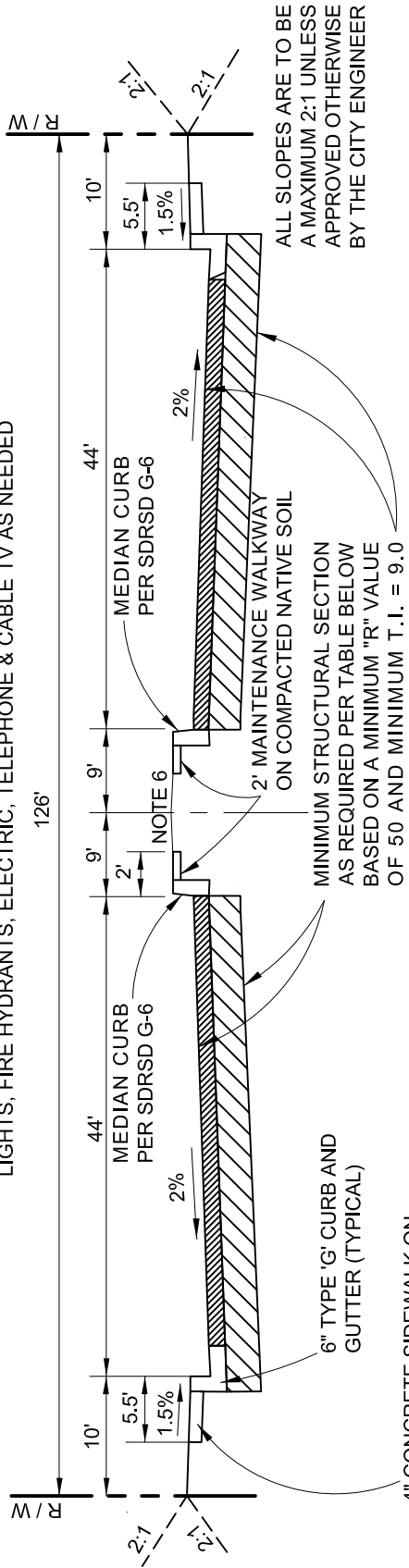

TYPICAL 6-LANE PRIME ARTERIAL (DIVIDED)

NO SCALE

MINIMUM PAVEMENT DESIGN REQUIREMENTS		
SUBBASE	BASE	SURFACE
N.A.	8" CLASS 2 AGGREGATE BASE	6" ASPHALT

1. THE PAVEMENT DEPTHS ARE MINIMUM COMPACTED DEPTHS.
2. THE PAVEMENT DESIGN IS BASED ON A MINIMUM TRAFFIC INDEX (T.I.) VALUE OF 9.0. THE ACTUAL DESIGN OF THE STREET STRUCTURAL SECTION SHALL BE BASED ON THE "R" VALUE OF THE SUBBASE SOIL AS DETERMINED BY A GEOTECHNICAL ENGINEER AT THE TIME OF CONSTRUCTION AND THE T.I. THE FINAL PAVEMENT DESIGN MUST BE APPROVED BY THE CITY ENGINEER.
3. MATERIALS AND CONSTRUCTION SHALL BE IN ACCORDANCE WITH THE LATEST EDITION OF THE GREENBOOK.
4. IF AN IRRIGATION SYSTEM IS PROPOSED WITHIN THE RW LIMITS, AN UNDERDRAIN SYSTEM MUST BE PROVIDED ADJACENT TO THE CURB AND GUTTER. A MAINTENANCE AGREEMENT FOR SAID SYSTEM MUST BE PROVIDED BETWEEN THE DEVELOPER AND THE CITY OF VISTA.
5. A UNIFORM STREET CROSS SECTIONAL WIDTH AND CONSISTENT PAVEMENT DESIGN ARE REQUIRED FOR ALL ROADWAYS.
6. A 4" THICK AND TWO FOOT (2') WIDE LANDSCAPE MAINTENANCE WALKWAY (STAMPED CONCRETE, BRICK PAVERS OR AS APPROVED BY CITY ENGINEER) SHALL BE CONSTRUCTED CONTIGUOUS TO THE MEDIAN CURB ADJACENT TO ALL MEDIAN LANDSCAPE AREAS.

Revision	By	Apprvd	Date
New	GL	TR	11/01/12

CITY OF VISTA
STANDARD DRAWING

**6 LANE PRIME ARTERIAL
(DIVIDED) TYPICAL SECTION**

[Signature]

CITY ENGINEER, DATE
RCE 55075

DRAWING NUMBER: **SRF-06A**

PUBLIC STREET AND UTILITY EASEMENT FOR STREET, SIDEWALK, STREET LIGHTS, FIRE HYDRANTS, ELECTRIC, TELEPHONE & CABLE TV AS NEEDED

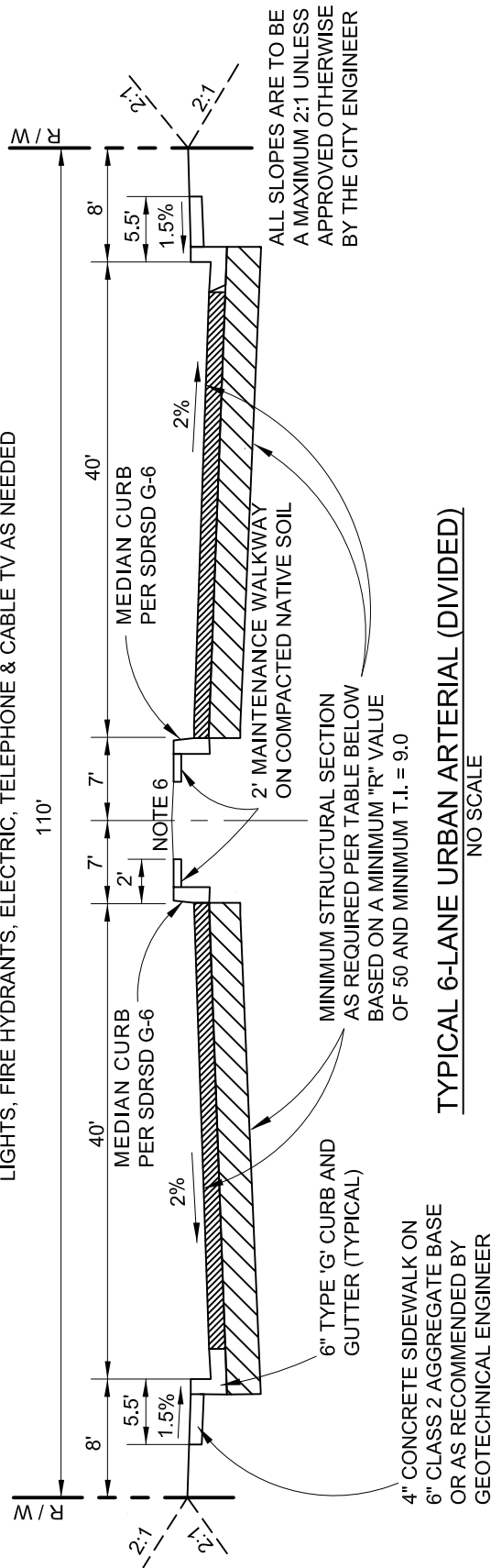

TYPICAL 6-LANE URBAN ARTERIAL (DIVIDED)

NO SCALE

MINIMUM PAVEMENT DESIGN REQUIREMENTS		
SUBBASE	BASE	SURFACE
N.A.	8" CLASS 2 AGGREGATE BASE	6" ASPHALT

1. THE PAVEMENT DEPTHS ARE MINIMUM COMPACTED DEPTHS.
2. THE PAVEMENT DESIGN IS BASED ON A MINIMUM TRAFFIC INDEX (T.I.) VALUE OF 9.0. THE ACTUAL DESIGN OF THE STREET STRUCTURAL SECTION SHALL BE BASED ON THE "R" VALUE OF THE SUBBASE SOIL AS DETERMINED BY A GEOTECHNICAL ENGINEER AT THE TIME OF CONSTRUCTION AND THE T.I. THE FINAL PAVEMENT DESIGN MUST BE APPROVED BY THE CITY ENGINEER.
3. MATERIALS AND CONSTRUCTION SHALL BE IN ACCORDANCE WITH THE LATEST EDITION OF THE GREENBOOK.
4. IF AN IRRIGATION SYSTEM IS PROPOSED WITHIN THE R/W LIMITS, AN UNDERDRAIN SYSTEM MUST BE PROVIDED ADJACENT TO THE CURB AND GUTTER. A MAINTENANCE AGREEMENT FOR SAID SYSTEM MUST BE PROVIDED BETWEEN THE DEVELOPER AND THE CITY OF VISTA.
5. A UNIFORM STREET CROSS SECTIONAL WIDTH AND CONSISTENT PAVEMENT DESIGN ARE REQUIRED FOR ALL ROADWAYS.
6. A 4" THICK AND TWO FOOT (2') WIDE LANDSCAPE MAINTENANCE WALKWAY (STAMPED CONCRETE, BRICK PAVERS OR AS APPROVED BY CITY ENGINEER) SHALL BE CONSTRUCTED CONTIGUOUS TO THE MEDIAN CURB ADJACENT TO ALL MEDIAN LANDSCAPE AREAS.

Revision	By	Apprvd	Date
New	GL	TR	11/01/12

CITY OF VISTA
STANDARD DRAWING

**6 LANE URBAN ARTERIAL
(DIVIDED) TYPICAL SECTION**

[Signature]
CITY ENGINEER, DATE
RCE 55075

DRAWING NUMBER: **SRF-06B**

PUBLIC STREET AND UTILITY EASEMENT FOR STREET, SIDEWALK, STREET LIGHTS, FIRE HYDRANTS, ELECTRIC, TELEPHONE & CABLE TV AS NEEDED

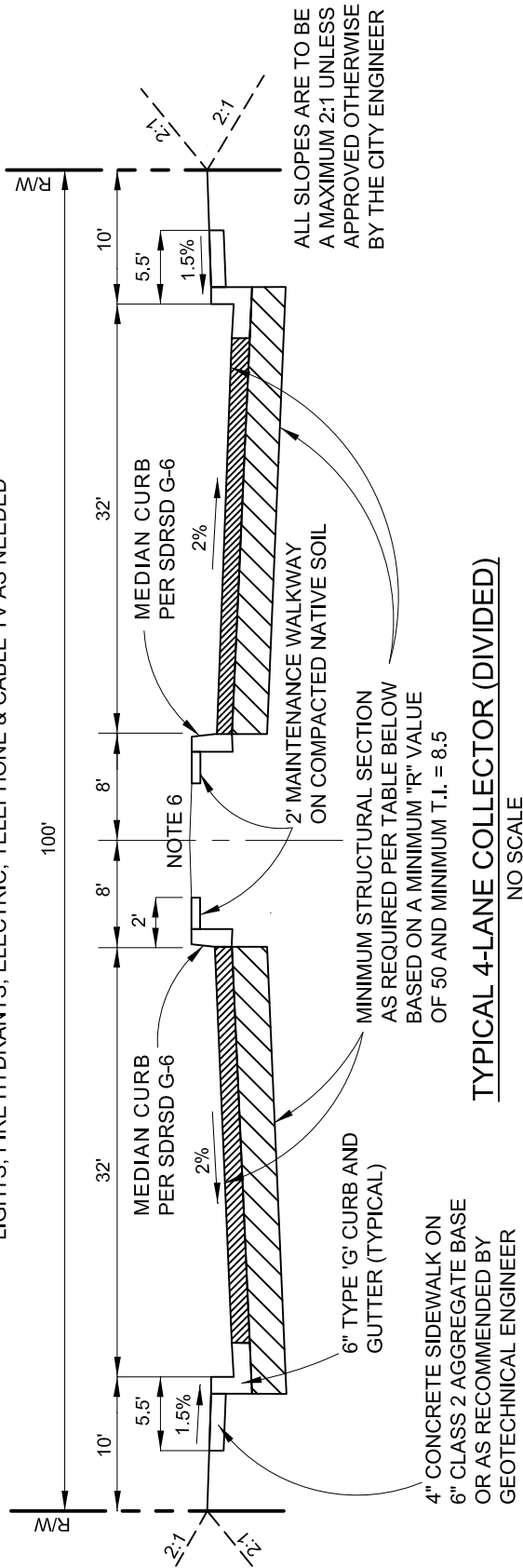

TYPICAL 4-LANE COLLECTOR (DIVIDED)
NO SCALE

MINIMUM PAVEMENT DESIGN REQUIREMENT		
SUBBASE	BASE	SURFACE
N.A.	8" CLASS 2 AGGREGATE BASE	5" ASPHALT

1. THE PAVEMENT DEPTHS ARE MINIMUM COMPACTED DEPTHS.
2. THE PAVEMENT DESIGN IS BASED ON A MINIMUM TRAFFIC INDEX (T.I.) VALUE OF 8.5. THE ACTUAL DESIGN OF THE STREET STRUCTURAL SECTION SHALL BE BASED ON THE "R" VALUE OF THE SUBBASE SOIL AS DETERMINED BY A GEOTECHNICAL ENGINEER AT THE TIME OF CONSTRUCTION AND THE T.I. THE FINAL PAVEMENT DESIGN MUST BE APPROVED BY THE CITY ENGINEER.
3. MATERIALS AND CONSTRUCTION SHALL BE IN ACCORDANCE WITH THE LATEST EDITION OF THE GREENBOOK.
4. IF AN IRRIGATION SYSTEM IS PROPOSED WITHIN THE RW LIMITS, AN UNDERDRAIN SYSTEM MUST BE PROVIDED ADJACENT TO THE CURB AND GUTTER. A MAINTENANCE AGREEMENT FOR SAID SYSTEM MUST BE PROVIDED BETWEEN THE DEVELOPER AND THE CITY OF VISTA.
5. A UNIFORM STREET CROSS SECTIONAL WIDTH AND CONSISTENT PAVEMENT DESIGN ARE REQUIRED FOR ALL ROADWAYS.
6. A 4" THICK AND TWO FOOT (2') WIDE LANDSCAPE MAINTENANCE WALKWAY (STAMPED CONCRETE, BRICK PAVERS OR AS APPROVED BY CITY ENGINEER) SHALL BE CONSTRUCTED CONTIGUOUS TO THE MEDIAN CURB ADJACENT TO ALL MEDIAN LANDSCAPE AREAS.

Revision	By	Apprvd	Date
New	GL	TR	11/01/12

CITY OF VISTA
STANDARD DRAWING

**4 LANE MAJOR ARTERIAL
(DIVIDED) TYPICAL SECTION**

[Signature]

CITY ENGINEER, DATE
RCE 55075

DRAWING NUMBER: **SRF-06C**

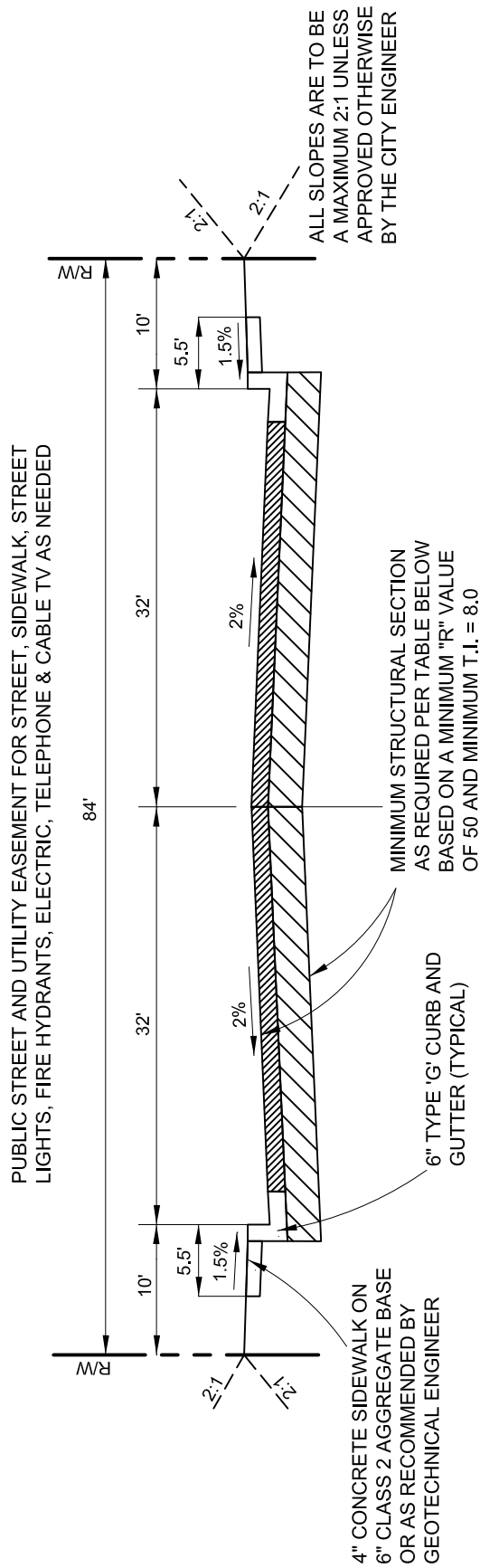

TYPICAL 4-LANE COLLECTOR (UNDIVIDED)
NO SCALE

MINIMUM PAVEMENT DESIGN REQUIREMENT		
SUBBASE	BASE	SURFACE
N.A.	8" CLASS 2 AGGREGATE BASE	4" ASPHALT

NOTES:

1. THE PAVEMENT DEPTHS ARE MINIMUM COMPACTED DEPTHS.
2. THE PAVEMENT DESIGN IS BASED ON A MINIMUM TRAFFIC INDEX (T.I.) VALUE OF 8.0. THE ACTUAL DESIGN OF THE STREET STRUCTURAL SECTION SHALL BE BASED ON THE "R" VALUE OF THE SUBBASE SOIL AS DETERMINED BY A GEOTECHNICAL ENGINEER AT THE TIME OF CONSTRUCTION AND THE T.I. THE FINAL PAVEMENT DESIGN MUST BE APPROVED BY THE CITY ENGINEER.
3. MATERIALS AND CONSTRUCTION SHALL BE IN ACCORDANCE WITH THE LATEST EDITION OF THE GREENBOOK.
4. IF AN IRRIGATION SYSTEM IS PROPOSED WITHIN THE R/W LIMITS, AN UNDERDRAIN SYSTEM MUST BE PROVIDED ADJACENT TO THE CURB AND GUTTER. A MAINTENANCE AGREEMENT FOR SAID SYSTEM MUST BE PROVIDED BETWEEN THE DEVELOPER AND THE CITY OF VISTA.
5. A UNIFORM STREET CROSS SECTIONAL WIDTH AND CONSISTENT PAVEMENT DESIGN ARE REQUIRED FOR ALL ROADWAYS.

Revision	By	Apprvd	Date
New	GL	TR	11/01/12

CITY OF VISTA
STANDARD DRAWING

4 LANE COLLECTOR (UNDIVIDED)
TYPICAL SECTION

[Signature]
CITY ENGINEER, DATE
RCE 55075

DRAWING NUMBER: **SRF-06D**

PUBLIC STREET AND UTILITY EASEMENT FOR STREET, SIDEWALK, STREET LIGHTS, FIRE HYDRANTS, ELECTRIC, TELEPHONE & CABLE TV AS NEEDED

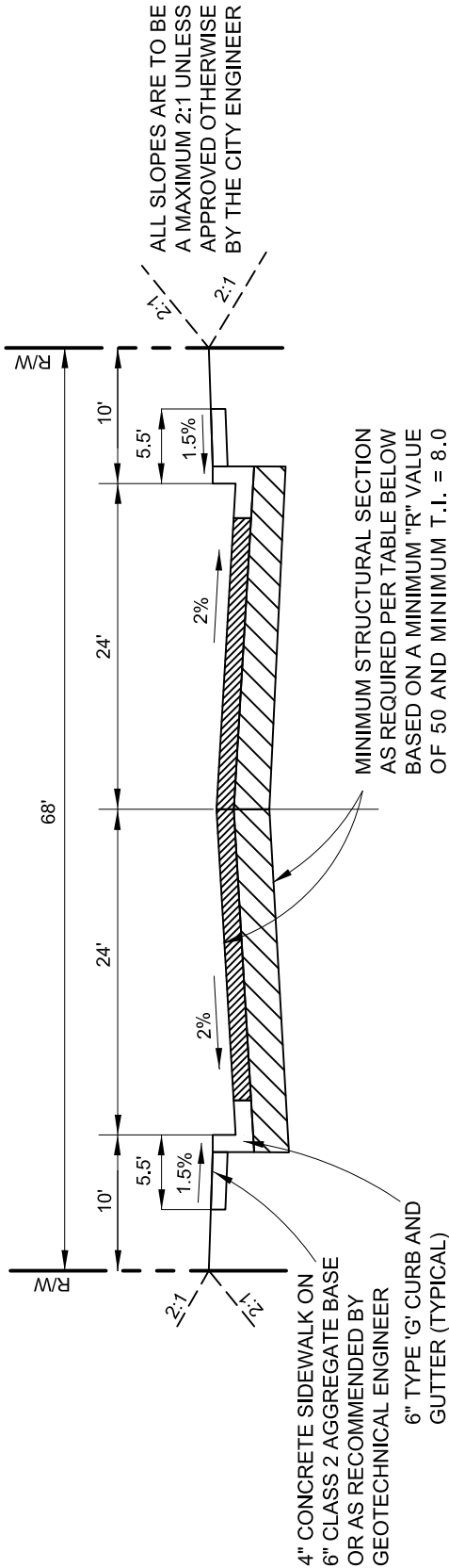

TYPICAL 2-LANE COLLECTOR WITH TWO-WAY LEFT TURN LANE (TWLTL)

NO SCALE

MINIMUM PAVEMENT DESIGN REQUIREMENT		
SUBBASE	BASE	SURFACE
N.A.	8" CLASS 2 AGGREGATE BASE	4" ASPHALT

1. THE PAVEMENT DEPTHS ARE MINIMUM COMPACTED DEPTHS.
2. THE PAVEMENT DESIGN IS BASED ON A MINIMUM TRAFFIC INDEX (T.I.) VALUE OF 8.0. THE ACTUAL DESIGN OF THE STREET STRUCTURAL SECTION SHALL BE BASED ON THE "R" VALUE OF THE SUBBASE SOIL AS DETERMINED BY A GEOTECHNICAL ENGINEER AT THE TIME OF CONSTRUCTION AND THE T.I. THE FINAL PAVEMENT DESIGN MUST BE APPROVED BY THE CITY ENGINEER.
3. MATERIALS AND CONSTRUCTION SHALL BE IN ACCORDANCE WITH THE LATEST EDITION OF THE GREENBOOK.
4. IF AN IRRIGATION SYSTEM IS PROPOSED WITHIN THE R/W LIMITS, AN UNDERDRAIN SYSTEM MUST BE PROVIDED ADJACENT TO THE CURB AND GUTTER. A MAINTENANCE AGREEMENT FOR SAID SYSTEM MUST BE PROVIDED BETWEEN THE DEVELOPER AND THE CITY OF VISTA.
5. A UNIFORM STREET CROSS SECTIONAL WIDTH AND CONSISTENT PAVEMENT DESIGN ARE REQUIRED FOR ALL ROADWAYS.

Revision	By	Apprvd	Date
New	GL	TR	11/01/12

CITY OF VISTA
STANDARD DRAWING

**2 LANE COLLECTOR
(WITH TWO-WAY LEFT TURN LANE)
TYPICAL SECTION**

[Signature]

CITY ENGINEER, DATE
RCE 55075

DRAWING NUMBER: **SRF-06E**

PUBLIC STREET AND UTILITY EASEMENT FOR STREET, SIDEWALK, STREET LIGHTS, FIRE HYDRANTS, ELECTRIC, TELEPHONE & CABLE TV AS NEEDED

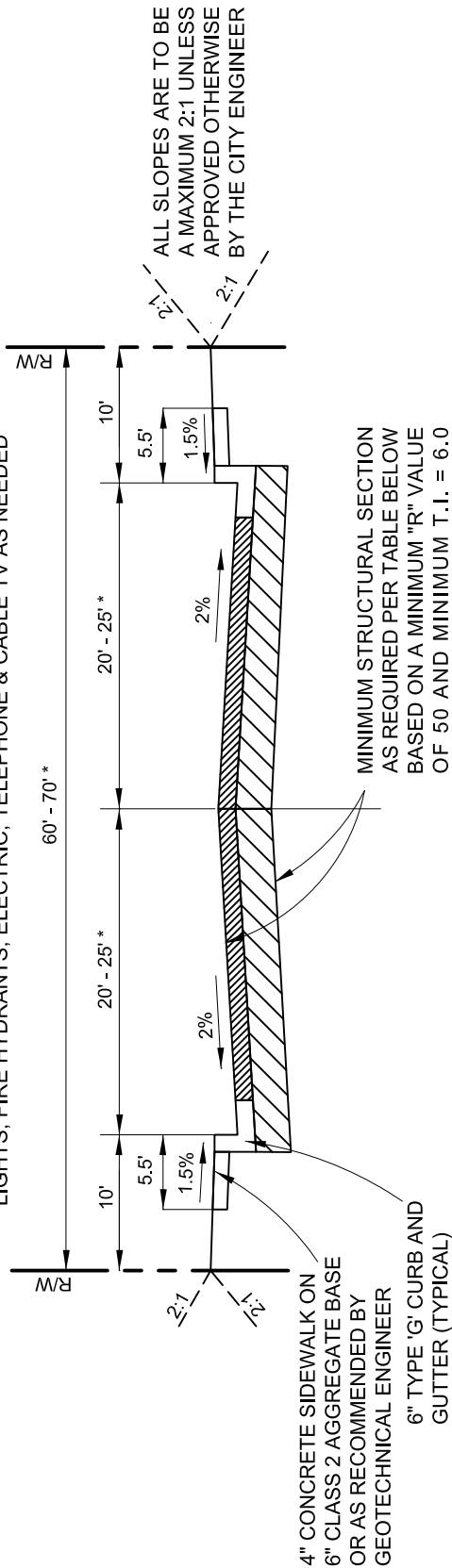

TYPICAL 2-LANE COLLECTOR
NO SCALE

MINIMUM PAVEMENT DESIGN REQUIREMENT		
SUBBASE	BASE	SURFACE
N.A.	8" CLASS 2 AGGREGATE BASE	4" ASPHALT

1. THE PAVEMENT DEPTHS ARE MINIMUM COMPACTED DEPTHS.
 2. THE PAVEMENT DESIGN IS BASED ON A MINIMUM TRAFFIC INDEX (T.I.) VALUE OF 6.0. THE ACTUAL DESIGN OF THE STREET STRUCTURAL SECTION SHALL BE BASED ON THE "R" VALUE OF THE SUBBASE SOIL AS DETERMINED BY A GEOTECHNICAL ENGINEER AT THE TIME OF CONSTRUCTION AND THE T.I. THE FINAL PAVEMENT DESIGN MUST BE APPROVED BY THE CITY ENGINEER.
 3. MATERIALS AND CONSTRUCTION SHALL BE IN ACCORDANCE WITH THE LATEST EDITION OF THE GREENBOOK.
 4. IF AN IRRIGATION SYSTEM IS PROPOSED WITHIN THE RAW LIMITS, AN UNDERDRAIN SYSTEM MUST BE PROVIDED ADJACENT TO THE CURB AND GUTTER. A MAINTENANCE AGREEMENT FOR SAID SYSTEM MUST BE PROVIDED BETWEEN THE DEVELOPER AND THE CITY OF VISTA.
 5. A UNIFORM STREET CROSS SECTIONAL WIDTH AND CONSISTENT PAVEMENT DESIGN ARE REQUIRED FOR ALL ROADWAYS.
- * FOR STREETS DESIGNED WITH A CENTER TURN LANE PER NOTE #15 ON CITY OF VISTA STANDARD DRAWING SRF-03C.

Revision	By	Apprvd	Date
New	GL	TR	11/01/12

CITY OF VISTA
STANDARD DRAWING

2 LANE COLLECTOR STREET
TYPICAL SECTION

[Signature]

CITY ENGINEER, DATE
RCE 55075

DRAWING NUMBER: **SRF-06F**

PUBLIC STREET AND UTILITY EASEMENT FOR STREET, SIDEWALK, STREET LIGHTS, FIRE HYDRANTS, ELECTRIC, TELEPHONE & CABLE TV AS NEEDED

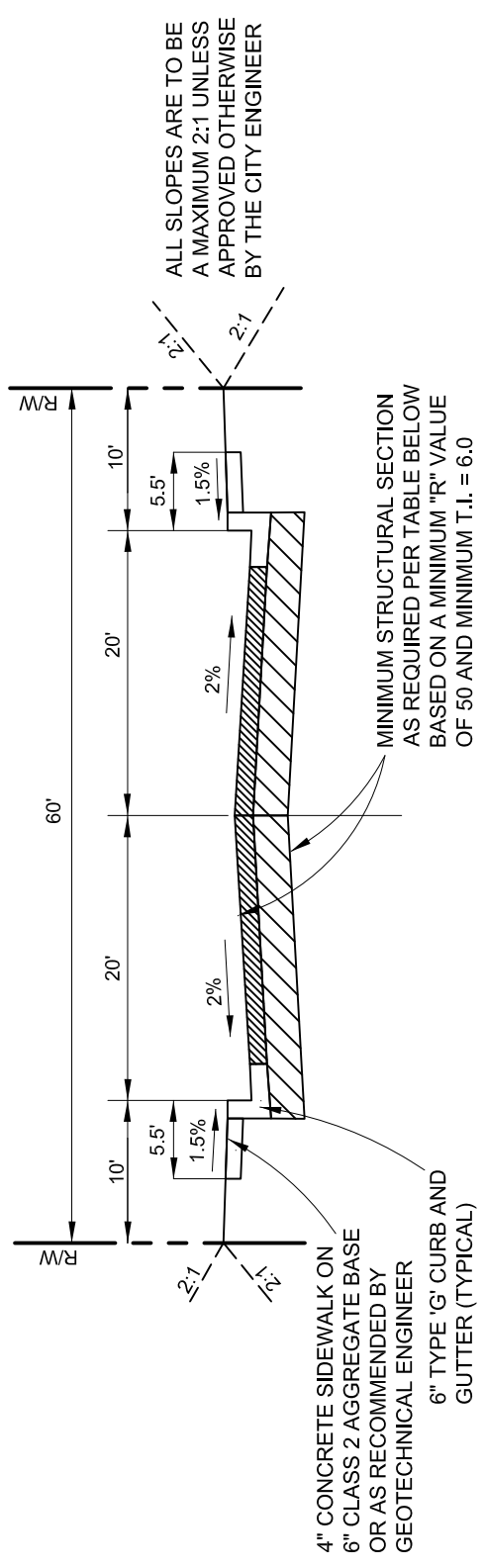

TYPICAL 2-LANE LITE COLLECTOR / LOCAL STREET

NO SCALE

MINIMUM PAVEMENT DESIGN REQUIREMENT		
SUBBASE	BASE	SURFACE
N.A.	8" CLASS 2 AGGREGATE BASE	4" ASPHALT

1. THE PAVEMENT DEPTHS ARE MINIMUM COMPACTED DEPTHS.
2. THE PAVEMENT DESIGN IS BASED ON A MINIMUM TRAFFIC INDEX (T.I.) VALUE OF 6.0. THE ACTUAL DESIGN OF THE STREET STRUCTURAL SECTION SHALL BE BASED ON THE "R" VALUE OF THE SUBBASE SOIL AS DETERMINED BY A GEOTECHNICAL ENGINEER AT THE TIME OF CONSTRUCTION AND THE T.I. THE FINAL PAVEMENT DESIGN MUST BE APPROVED BY THE CITY ENGINEER.
3. MATERIALS AND CONSTRUCTION SHALL BE IN ACCORDANCE WITH THE LATEST EDITION OF THE GREENBOOK.
4. IF AN IRRIGATION SYSTEM IS PROPOSED WITHIN THE RW LIMITS, AN UNDERDRAIN SYSTEM MUST BE PROVIDED ADJACENT TO THE CURB AND GUTTER. A MAINTENANCE AGREEMENT FOR SAID SYSTEM MUST BE PROVIDED BETWEEN THE DEVELOPER AND THE CITY OF VISTA.
5. A UNIFORM STREET CROSS SECTIONAL WIDTH AND CONSISTENT PAVEMENT DESIGN ARE REQUIRED FOR ALL ROADWAYS

Revision	By	Apprvd	Date
New	GL	TR	11/01/12

CITY OF VISTA
STANDARD DRAWING

2 LANE LIT COLLECTOR/LOCAL STREET TYPICAL SECTION

[Signature]
CITY ENGINEER, DATE
RCE 55075

DRAWING NUMBER: **SRF-06G**

PUBLIC STREET AND UTILITY EASEMENT FOR STREET, SIDEWALK, STREET LIGHTS, FIRE HYDRANTS, ELECTRIC, TELEPHONE & CABLE TV AS NEEDED

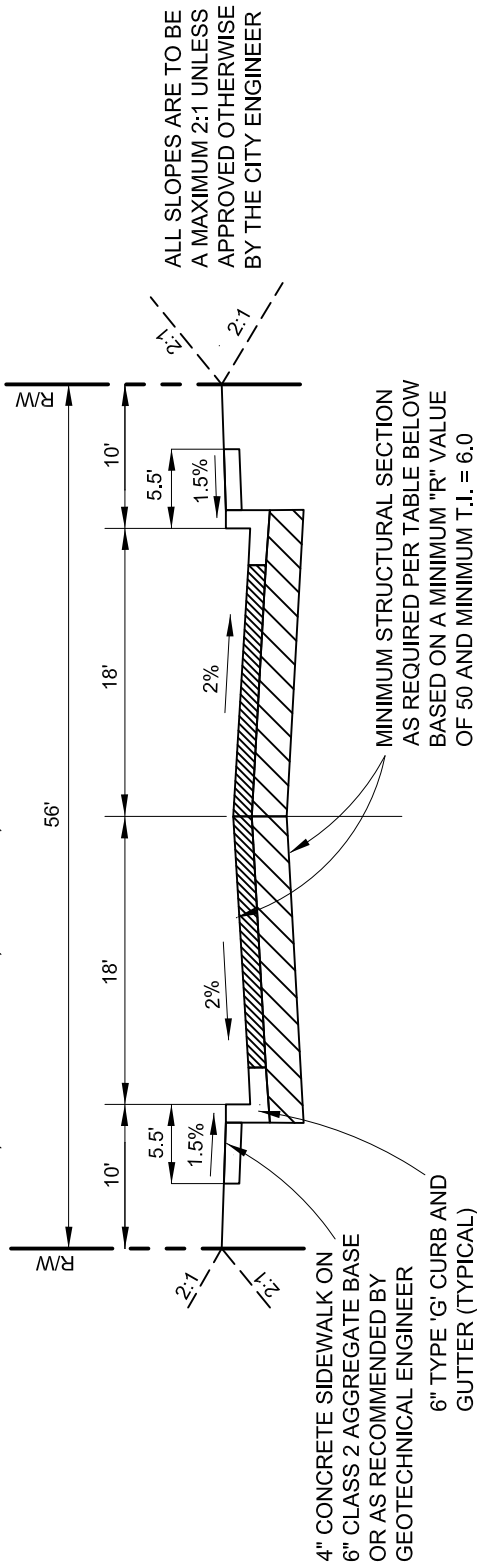

TYPICAL CUL-DE-SAC STREET

NO SCALE

MINIMUM PAVEMENT DESIGN REQUIREMENT		
SUBBASE	BASE	SURFACE
N.A.	8" CLASS 2 AGGREGATE BASE	4" ASPHALT

1. THE PAVEMENT DEPTHS ARE MINIMUM COMPACTED DEPTHS.
2. THE PAVEMENT DESIGN IS BASED ON A MINIMUM TRAFFIC INDEX (T.I.) VALUE OF 6.0. THE ACTUAL DESIGN OF THE STREET STRUCTURAL SECTION SHALL BE BASED ON THE "R" VALUE OF THE SUBBASE SOIL AS DETERMINED BY A GEOTECHNICAL ENGINEER AT THE TIME OF CONSTRUCTION AND THE T.I. THE FINAL PAVEMENT DESIGN MUST BE APPROVED BY THE CITY ENGINEER.
3. MATERIALS AND CONSTRUCTION SHALL BE IN ACCORDANCE WITH THE LATEST EDITION OF THE GREENBOOK.
4. IF AN IRRIGATION SYSTEM IS PROPOSED WITHIN THE R/W LIMITS, AN UNDERDRAIN SYSTEM MUST BE PROVIDED ADJACENT TO THE CURB AND GUTTER. A MAINTENANCE AGREEMENT FOR SAID SYSTEM MUST BE PROVIDED BETWEEN THE DEVELOPER AND THE CITY OF VISTA.
5. A UNIFORM STREET CROSS SECTIONAL WIDTH AND CONSISTENT PAVEMENT DESIGN ARE REQUIRED FOR ALL ROADWAYS.

Revision	By	Apprvd	Date
New	GL	TR	11/01/12

CITY OF VISTA
STANDARD DRAWING

CUL-DE-SAC STREET
TYPICAL SECTION

[Signature]
CITY ENGINEER, DATE
RCE 55075

DRAWING NUMBER: **SRF-06H**

PUBLIC STREET AND UTILITY EASEMENT FOR STREET, SIDEWALK, STREET LIGHTS, FIRE HYDRANTS, ELECTRIC, TELEPHONE & CABLE TV AS NEEDED

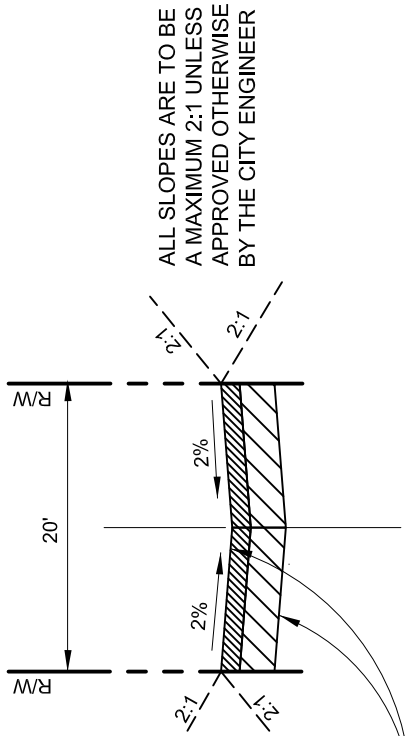

MINIMUM STRUCTURAL SECTION AS REQUIRED PER TABLE BELOW BASED ON A MINIMUM "R" VALUE OF 50 AND MINIMUM T.I. = 6.0

TYPICAL ALLEY
NO SCALE

MINIMUM PAVEMENT DESIGN REQUIREMENT		
SUBBASE	BASE	SURFACE
N.A.	8" CLASS 2 AGGREGATE BASE	4" ASPHALT
N.A.	8" CLASS 2 AGGREGATE BASE	5-1/2" 560-C-3250 CONCRETE

1. THE PAVEMENT DEPTHS ARE MINIMUM COMPACTED DEPTHS.
2. THE PAVEMENT DESIGN IS BASED ON A MINIMUM TRAFFIC INDEX (T.I.) VALUE OF 6.0. THE ACTUAL DESIGN OF THE STREET STRUCTURAL SECTION SHALL BE BASED ON THE "R" VALUE OF THE SUBBASE SOIL AS DETERMINED BY A GEOTECHNICAL ENGINEER AT THE TIME OF CONSTRUCTION AND THE T.I. THE FINAL PAVEMENT DESIGN MUST BE APPROVED BY THE CITY ENGINEER.
3. MATERIALS AND CONSTRUCTION SHALL BE IN ACCORDANCE WITH THE LATEST EDITION OF THE GREENBOOK.
4. A UNIFORM STREET CROSS SECTIONAL WIDTH AND CONSISTENT PAVEMENT DESIGN ARE REQUIRED FOR ALL ROADWAYS.
5. 5-1/2" OF CONCRETE (560-C-3250) OVER 6" OF CLASS 2 AGGREGATE BASE MAY BE SUBSTITUTED FOR THE 4" ASPHALT CONCRETE OVER 8" OF CLASS 2 AGGREGATE BASE.

Revision	By	Apprvd	Date
New	GL	TR	11/01/12

CITY OF VISTA
STANDARD DRAWING

ALLEY
TYPICAL SECTION

[Signature]
CITY ENGINEER, DATE
RCE 55075

DRAWING NUMBER: **SRF-06J**

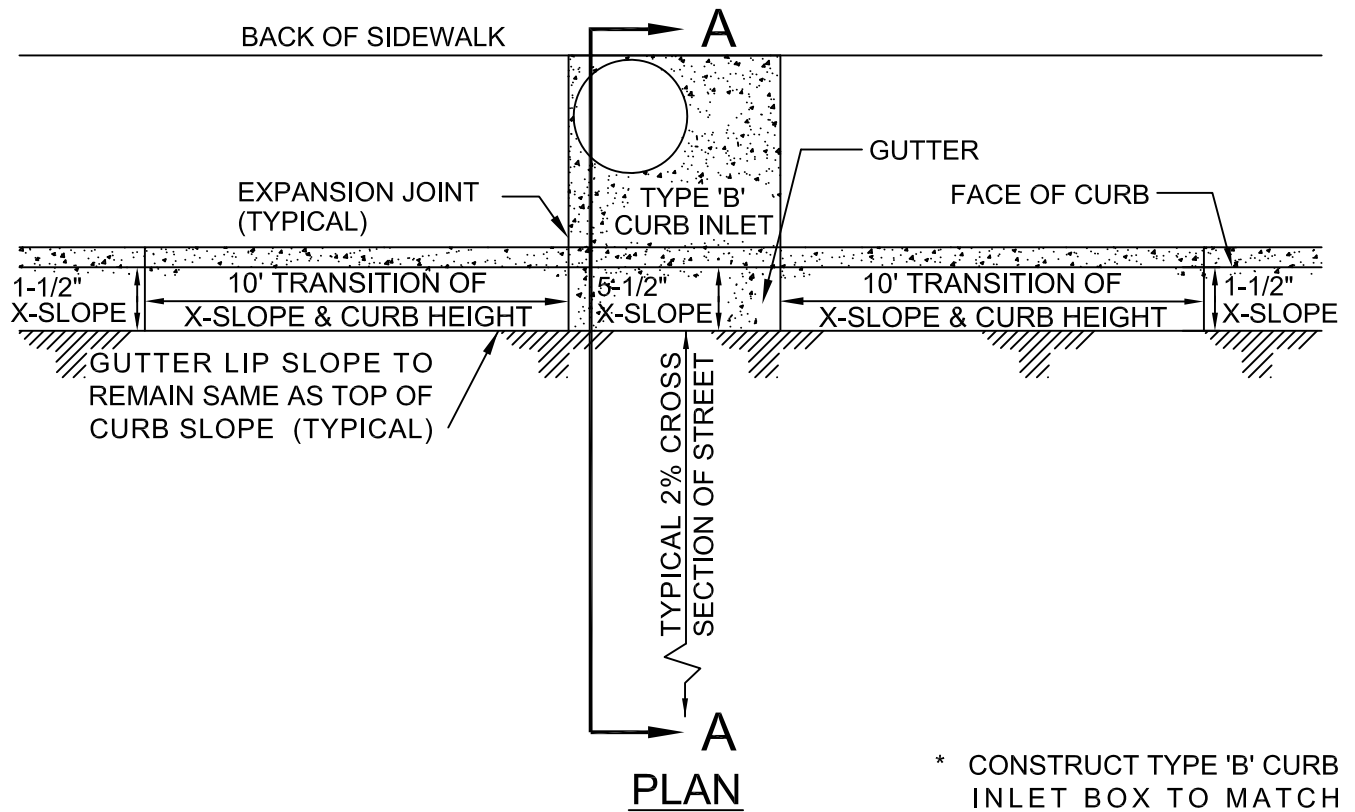

* CONSTRUCT TYPE 'B' CURB INLET BOX TO MATCH BACK OF SIDEWALK WIDTH (TYPICAL MINIMUM 5.5')

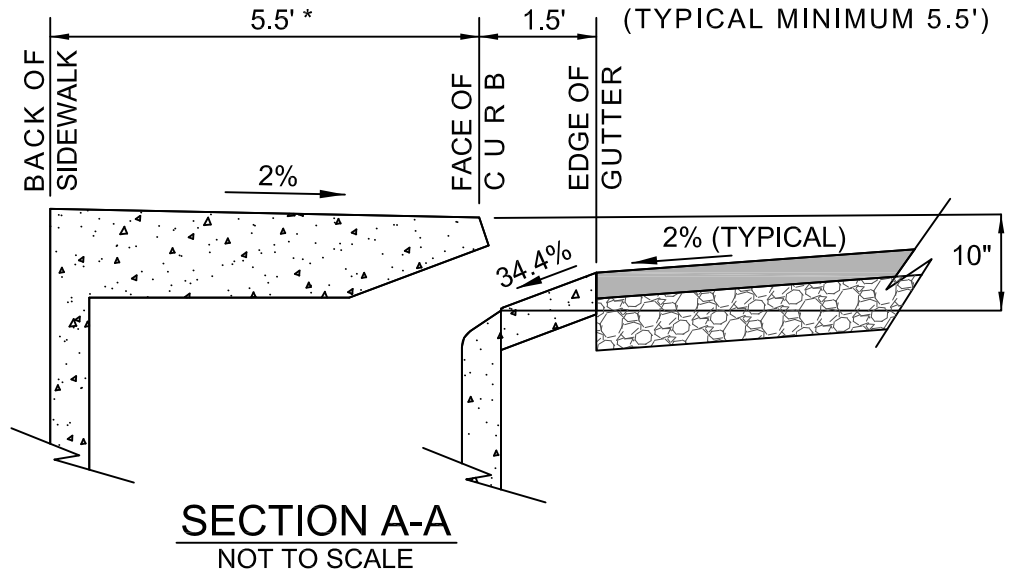

NOTE:

1. THIS GUTTER TRANSITION SHALL BE USED WITH THE CONSTRUCTION OF TYPE 'B' CURB INLETS.
2. GUTTER TRANSITION SHALL BEGIN 10' FROM BOTH SIDES OF CURB INLET BY MAINTAINING THE SAME ELEVATION DIFFERENCE BETWEEN THE TOP OF CURB AND THE EDGE OF GUTTER, BUT WARPING THE X-SLOPE OF THE CONCRETE GUTTER FROM THE TYPICAL 9.4% (ASSUMING A 6" TYPE 'G' CURB FACE) TO A 34.4% X-SLOPE WITH A 10" CURB FACE AT THE EDGES OF CURB INLET.

Revision	By	Apprvd	Date
Updated	TR	SS	08/22/08
Updated	TR	GM	10/23/12

CITY OF VISTA
STANDARD DRAWING

**GUTTER TRANSITION
FOR TYPE 'B' CURB INLETS**

[Signature]
CITY ENGINEER, DATE
RCE 55075

DRAWING NUMBER: **SRF-07**

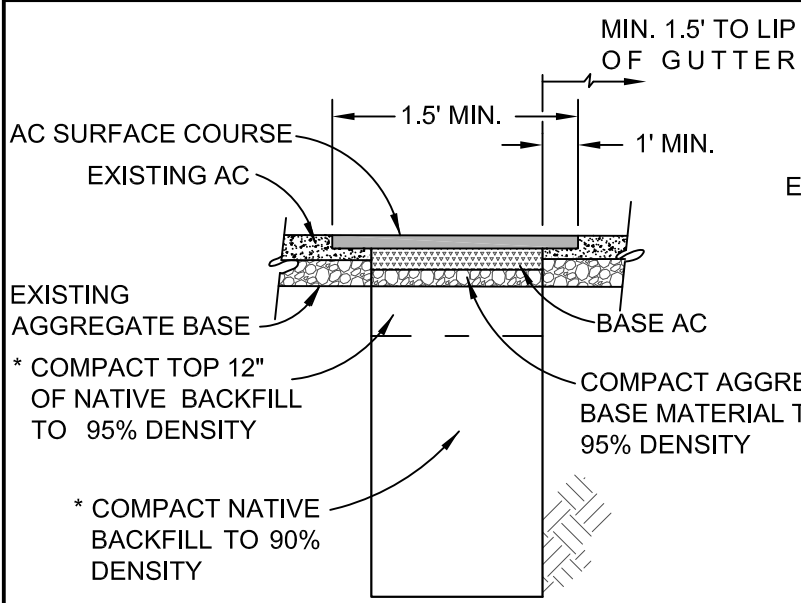

TYPE A
EXCAVATED TRENCH
 (SEE SRF-08B FOR TRENCH PAVING NOTES)

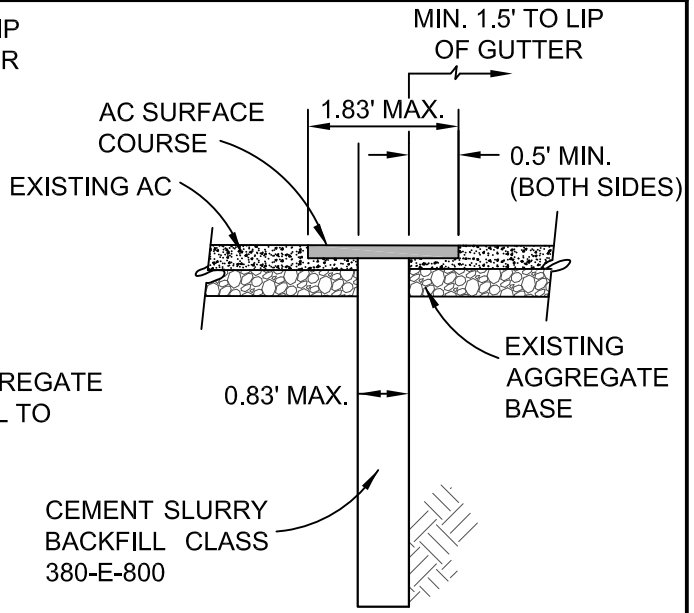

TYPE B
ROCKSAW TRENCH
 (SEE SRF-08B FOR TRENCH PAVING NOTES)

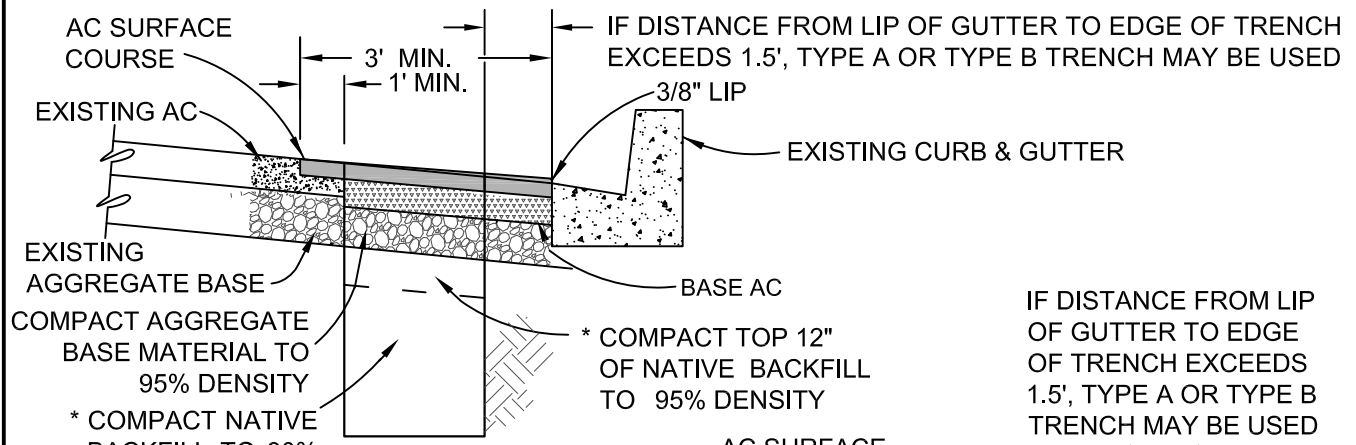

TYPE C
TRENCH ADJACENT TO GUTTER
(ROCKSAW OR EXCAVATED)
 (SEE SRF-08B FOR TRENCH PAVING NOTES)

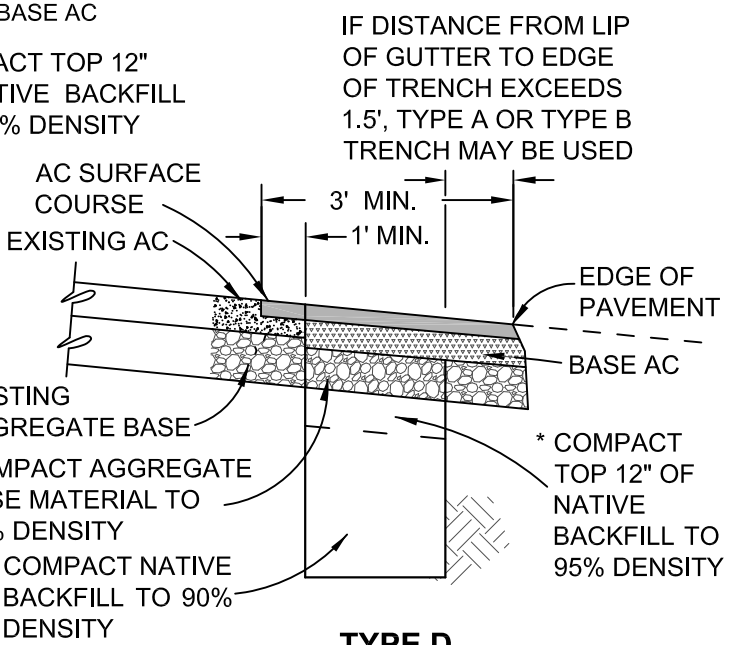

TYPE D
TRENCH AT EDGE OF PAVEMENT
 (SEE SRF-08B FOR TRENCH PAVING NOTES)

ASPHALT LEGEND	
	NEW 1/2" MEDIUM ASPHALT
	NEW 3/4" MEDIUM ASPHALT
	EXISTING ASPHALT

* NATIVE BACKFILL = S.E. 30 (MINIMUM);
 NATIVE BACKFILL MAY BE REPLACED WITH 2 SACK
 CEMENT SLURRY IF APPROVED BY CITY ENGINEER

Revision	By	Apprvd	Date
New		DS	10/89
Updated	GL	TS	05/07/12

CITY OF VISTA
 STANDARD DRAWING

TRENCH RESURFACING

CITY ENGINEER, DATE
 RCE 55075

DRAWING NUMBER: **SRF-08A**

GENERAL PROVISIONS

- A. THE GENERAL CONTRACTOR IS REQUIRED TO OBTAIN A CITY RIGHT-OF-WAY PERMIT FOR ANY AND ALL WORK PERFORMED WITHIN THE CITY RIGHT-OF-WAY.
- B. ALL WORK PERFORMED REQUIRES CITY INSPECTION.
- C. IN NO CASE SHALL TEMPORARY ASPHALT OR PLATES BE LEFT IN PLACE LONGER THAN TEN (10) WORKING DAYS ABOVE TRENCH TYPES A, C & D; NO TRENCHES SHALL BE LEFT OPEN OVERNIGHT.
- D. CONSTRUCTION MATERIALS & CONSTRUCTION METHODS ARE CONSIDERED THE MINIMUM REQUIRED AND MAY BE REVISED BY THE CITY AT ANY TIME.
- E. ALL TRENCHING REQUIRES COMPACTION TESTING OF THE BACKFILL AND AGGREGATE BASE UNLESS WAIVED BY THE CITY ENGINEER.
- F. ALL TRENCH PLATES SHALL BE RECESSED (SEE STANDARD DRAWINGS SRF-11A & SRF-11B).

CONSTRUCTION MATERIALS

- A. ASPHALT CONCRETE (AC): 1/2" SURFACE COURSE = C2-AR-4000-RAP; 3/4" BASE COURSE = B-AR-4000-RAP (PERFORMANCE GRADE (PG) ASPHALT BINDER PG 64-10 MAYBE SUBSTITUTED FOR THE SPECIFIED AR GRADE ASPHALT BINDER).
- B. AGGREGATE BASE: CLASS 2 (PER CALTRANS SPECIFICATION SUBSECTION 26-1.02B) OR CRUSHED AGGREGATE BASE (PER 2012 GREENBOOK SUBSECTION 200-2.2).
- C. SLURRY BACKFILL: ROCKSAW TRENCH - CLASS 380-E-800; ALL OTHER: CLASS 190-E-400 (OR AS APPROVED).
- D. TACK COAT: AR-4000 PAVING ASPHALT OR GRADE SS-1h EMULSIFIED ASPHALT (PER 2012 GREENBOOK SUBSECTION 302-5.4).

CONSTRUCTION METHODS

A. TYPE A, C & D TRENCHES

- 1. EXISTING AC PAVING SHALL BE SAWCUT AND REMOVED ALONG CLEAN, STRAIGHT LINES, TAKING CARE NOT TO UPLIFT OR TEAR ADJOINING PAVING (PER 2012 GREENBOOK 300-1.3.2).
- 2. AGGREGATE BASE MATERIAL TO BE REPLACED TO DEPTH OF EXISTING BASE. A MINIMUM OF 6" AC MAY BE SUBSTITUTED FOR BASE WITH PRIOR CITY APPROVAL.
- 3. A TACK COAT OF ASPHALTIC EMULSION OR PAVING ASPHALT SHALL BE APPLIED TO ALL CONTACT SURFACES.
- 4. AC BASE COURSE TO MEET EXISTING STREET GRADE - LEAVING DEPRESSIONS FOR CAP PAVING IS NOT ALLOWED.
- 5. AC BASE COURSE DEPTH SHALL BE 1" DEEPER THAN EXISTING - MINIMUM 4" DEPTH AC SHALL BE HOT-PLANT MIX.
- 6. COLD PLANE EXISTING AC PAVEMENT TO A MINIMUM DEPTH OF ONE-HALF THICKNESS OF EXISTING AC - NOT TO EXCEED 2".
- 7. AC SURFACE COURSE SHALL BE PLACED USING A SPREADER BOX OR PAVING MACHINE AND SHALL BE DENSIFIED / FINISHED PER 2012 GREENBOOK 302-5.6.1 & 302-5.6.2.
- 8. AC RESURFACING SHALL BE SEAL COATED WITH EMULSIFIED ASPHALT AND COVERED WITH SAND UNLESS WAIVED BY CITY ENGINEER.

B. TYPE B TRENCH

- 1. CEMENT SLURRY SHALL HAVE A MINIMUM 4" SLUMP AND BE THOROUGHLY CONSOLIDATED WITH VIBRATORS AND TAMPED.
- 2. CEMENT SLURRY SHALL BE LEFT 1/2" LOW FROM EXISTING STREET SURFACE; TEMPORARY AC SHALL BE PLACED OVER SLURRY IN ALL AREAS SUBJECT TO VEHICLE OR PEDESTRIAN TRAFFIC.
- 3. ALLOW SLURRY FIVE (5) DAYS TO CURE BEFORE PLANING.
- 4. COLD PLANE EXISTING AC PAVEMENT TO A MINIMUM DEPTH OF ONE-HALF THICKNESS OF EXISTING AC - NOT TO EXCEED 2".
- 5. A TACK COAT OF ASPHALTIC EMULSION OR PAVING ASPHALT SHALL BE APPLIED TO ALL SURFACES.
- 6. AC SURFACE COURSE SHALL BE PLACED USING A SPREADER BOX OR PAVING MACHINE AND SHALL BE DENSIFIED / FINISHED PER 2012 GREENBOOK 302-5.6.1 & 302-5.6.2.
- 7. AC RESURFACING SHALL BE SEAL COATED WITH EMULSIFIED ASPHALT AND COVERED WITH SAND UNLESS WAIVED BY CITY ENGINEER.

Revision	By	Apprvd	Date	CITY OF VISTA STANDARD DRAWING	
New		DS	10/89		
Updated	GL	TS	05/07/12	TRENCH RESURFACING STANDARD NOTES	CITY ENGINEER, DATE RCE 55075
					DRAWING NUMBER: SRF-08B

THIS SHEET
INTENTIONALLY LEFT BLANK

Revision	By	Apprvd	Date	CITY OF VISTA STANDARD DRAWING		
						CITY ENGINEER, DATE
						RCE 55075
						DRAWING NUMBER: SRF-09

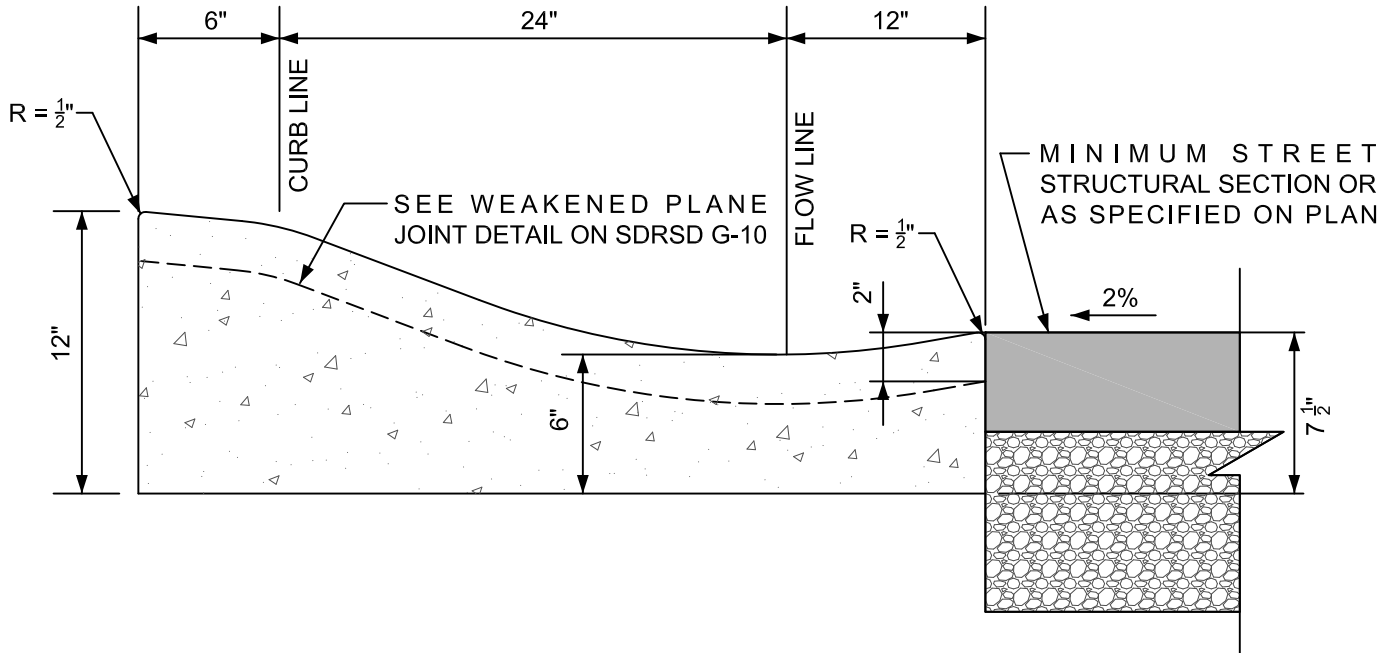

MODIFIED ROLLED CURB AND GUTTER

NOTES:

1. PCC SHALL BE 560-C-3250 CONCRETE (6-SACK) MINIMUM IN ACCORDANCE WITH THE LATEST EDITION OF THE STANDARD SPECIFICATIONS FOR PUBLIC WORKS CONSTRUCTION ("GREENBOOK").
2. TRANSITION TO A TYPE "G" CURB & GUTTER PER SDRSD G-2 AT ALL CUL-DE-SACS WITH DRAINAGE STRUCTURES AND AT ALL CURB RETURNS IF A PEDESTRIAN RAMP IS NOT PROVIDED.

Revision	By	Apprvd	Date	CITY OF VISTA STANDARD DRAWING	 CITY ENGINEER, DATE RCE 55075
New	TR	SS	04/20/08	MODIFIED ROLLED CURB TRANSITION DETAIL	DRAWING NUMBER: SRF-10A

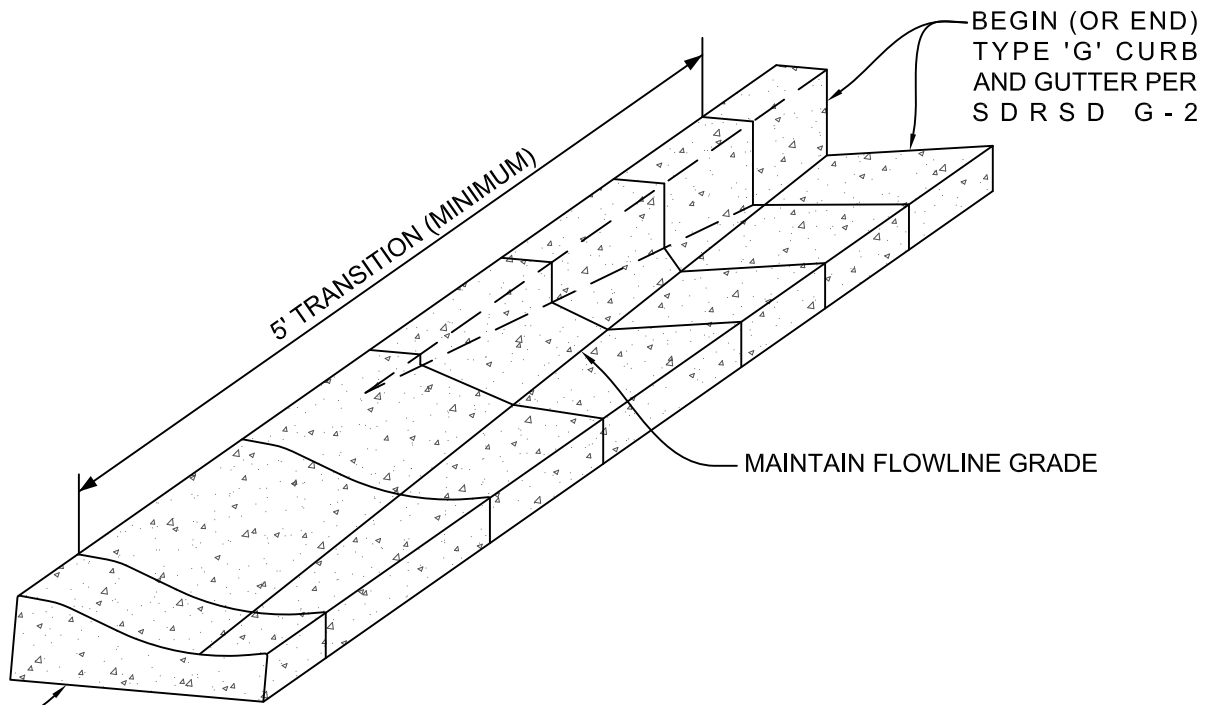

ISOMETRIC VIEW

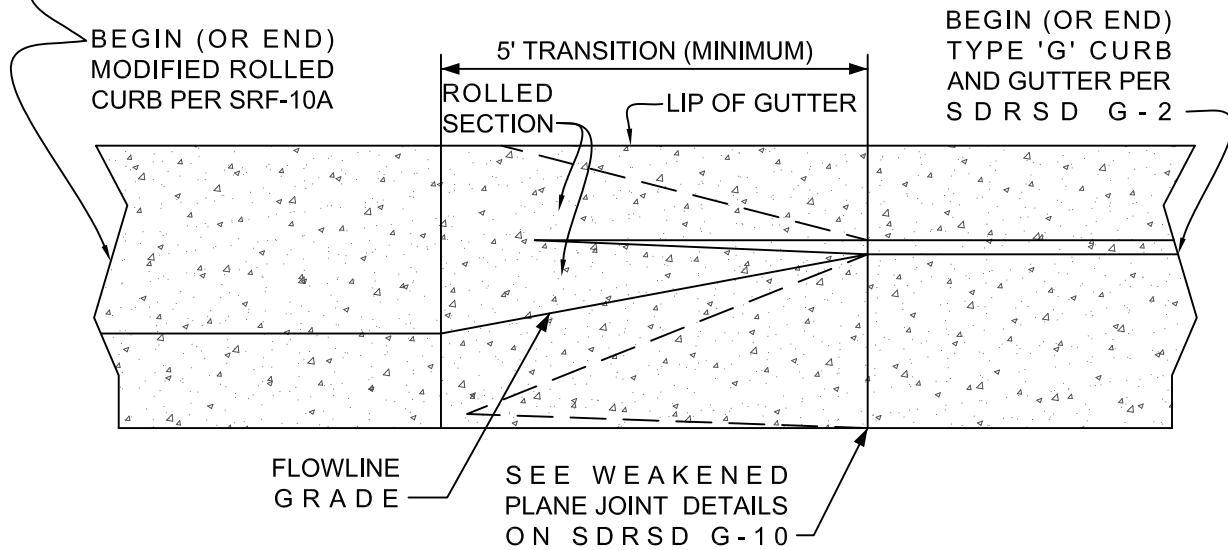

PLAN VIEW

NOTES:

1. PCC SHALL BE 560-C-3250 CONCRETE (6-SACK) MINIMUM IN ACCORDANCE WITH THE LATEST EDITION OF THE STANDARD SPECIFICATIONS FOR PUBLIC WORKS CONSTRUCTION ("GREENBOOK").
2. TRANSITION TO A TYPE G CURB & GUTTER PER SDRSD G-2 AT ALL CUL-DE-SACS WITH DRAINAGE STRUCTURES AND AT ALL CURB RETURNS IF A PEDESTRIAN RAMP IS NOT PROVIDED.

Revision	By	Apprvd	Date	CITY OF VISTA STANDARD DRAWING	 CITY ENGINEER, DATE RCE 55075
New	TR	SS	04/20/08		

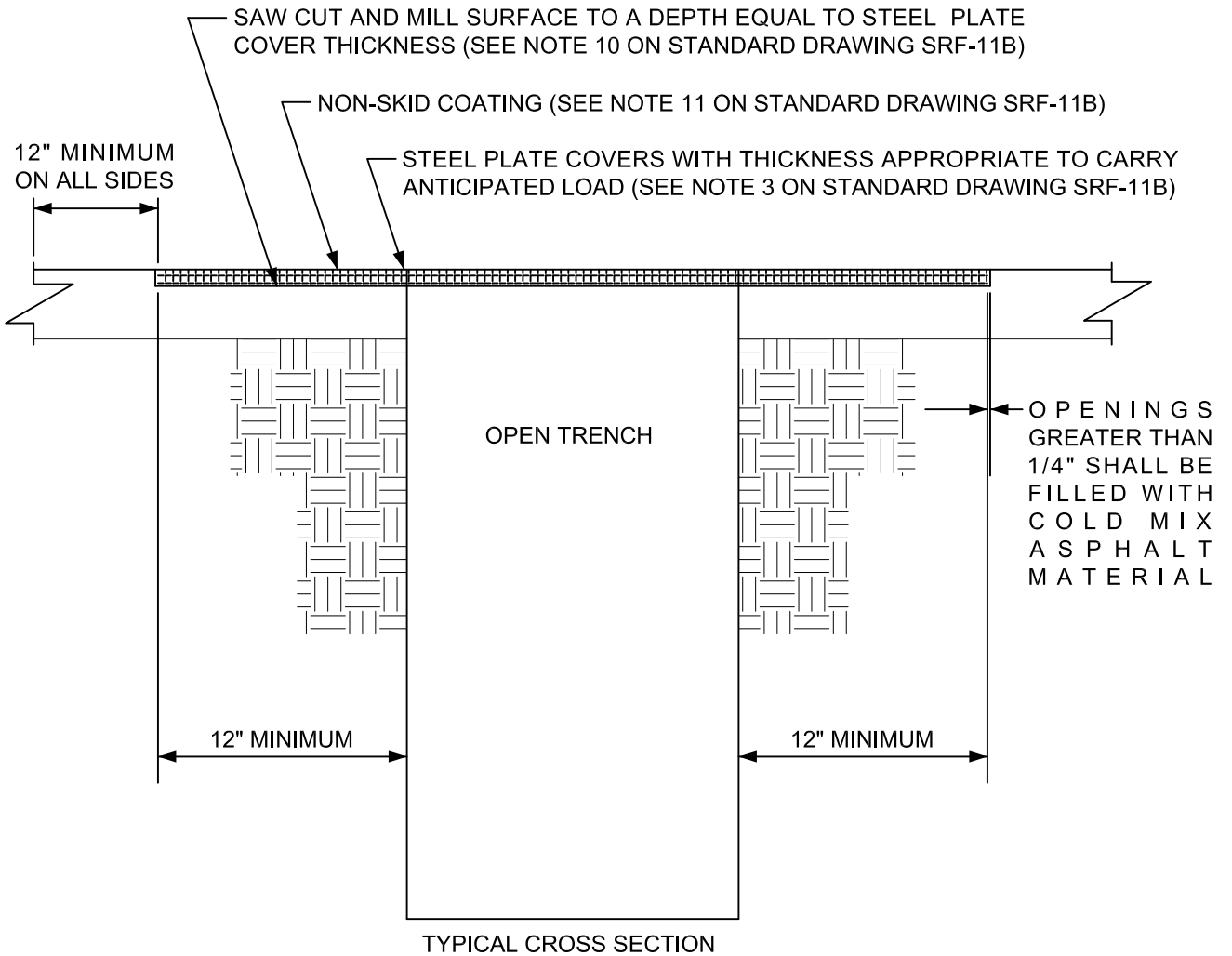

Revision	By	Apprvd	Date
New	TR	SS	11/30/08

CITY OF VISTA
STANDARD DRAWING

TEMPORARY STEEL PLATE
COVERS

[Signature]
CITY ENGINEER, DATE
RCE 55075
DRAWING NUMBER: SRF-11A

NOTES:

1. THE CONTRACTOR SHALL PROVIDE SUITABLE STEEL PLATE COVERS WHERE TRAFFIC MUST CROSS TRENCHES.
2. THE USE OF STEEL PLATE COVERS SHALL BE APPROVED BY THE ENGINEERING INSPECTION DIVISION PRIOR TO INITIATION OF CONSTRUCTION.
3. SEE SAN DIEGO REGIONAL "GREENBOOK" SUPPLEMENT SUBSECTION 7-10.5.3 FOR STEEL PLATE COVER THICKNESS TABLE. THE THICKNESS OF THE STEEL PLATE COVERS FOR TRENCH WIDTHS EXCEEDING SIXTY-THREE INCHES (63") SHALL BE ESTABLISHED IN AN ANALYSIS COMPLETED BY A LICENSED PROFESSIONAL CIVIL OR STRUCTURAL ENGINEER REGISTERED IN THE STATE OF CALIFORNIA. THE ANALYSIS SHALL BE BASED ON A-36 GRADE STEEL WITH HS20-44 TRUCK LOADING PER THE CALTRANS BRIDGE DESIGN SPECIFICATIONS MANUAL AND A MAXIMUM STEEL PLATE COVER DEFLECTION OF 1/2" WHEN EXPERIENCING SAID LOADING. FOR SITUATIONS WHERE MULTIPLE LAYERS OF STEEL PLATE COVERS (OR STACKED STEEL PLATE COVERS) ARE TO BE EMPLOYED, THE SEAMS (I.E. THE INTERFACE BETWEEN THE STEEL PLATE COVERS SIDE-BY-SIDE) OF THE UPPER LAYER SHALL BE PLACED PERPENDICULAR TO THE SEAMS OF THE UNDERLYING STEEL PLATE COVERS.
4. TEMPORARY STEEL PLATE COVER INSTALLATION SHALL NOT EXCEED FOUR (4) CONSECUTIVE WORKING DAYS.
5. THE TOPSIDE OF THE STEEL PLATE COVERS SHALL BE FLAT AND FREE OF ANY CLIPS, CHAINS, ATTACHMENTS, WELDMENTS OR SURFACE IRREGULARITIES.
6. STEEL PLATE COVERS WITH A PERMANENT DISPLACEMENT (I.E. DISPLACEMENT ANYWHERE ON THE SURFACE OF THE STEEL PLATE COVER WITH RESPECT TO A PLANE FORMED BY THE OUTSIDE EDGES) THAT EXCEEDS 1/2" SHALL NOT BE USED FOR STEEL PLATE COVERING PURPOSES. STEEL PLATE COVERS THAT DEVELOP A PERMANENT DISPLACEMENT EXCEEDING 1/2" DURING SERVICE SHALL BE REMOVED AND REPLACED.
7. THE STEEL PLATE COVERS SHALL BE PROVIDED WITH THE APPROPRIATE NUMBER OF KEYHOLE SLOTS OR CIRCULAR HOLES FOR HANDLING, LIFTING, INSTALLATION AND REMOVAL PURPOSES.
8. THE CONTRACTOR SHALL AVOID USING A LONG SERIES OF STEEL PLATE COVERS THAT RUN PARALLEL TO VEHICULAR TRAFFIC WHEEL PATH.
9. STEEL PLATE COVERS SHALL BE INSTALLED TO OPERATE WITH MINIMUM NOISE.
10. THE PAVEMENT SHALL BE COLD-MILLED TO A DEPTH EQUAL TO THE THICKNESS OF THE STEEL PLATE COVER AND TO A WIDTH AND LENGTH EQUAL TO THE DIMENSIONS OF THE STEEL PLATE COVER. ADDITIONAL METHODS OF SECURING STEEL PLATE COVERS MAYBE REQUIRED DEPENDING ON FIELD CONDITIONS.
11. THE SURFACE OF ALL STRUCUTRAL STEEL PLATE COVERS USED BY THE CONTRACTOR TO BRIDGE ANY EXCAVATION IN THE PUBLIC RIGHT-OF-WAY SHALL HAVE A NON-SKID COATING ("SKID GUARD" OR EQUAL) WITH A MINIMUM COEFFICIENT OF FRICTION = 0.35 PER CALIFORNIA TEST METHOD 342 FOR ALL TRAFFIC STEEL PLATE COVERS WITHIN THE TRAVELED ROADWAY OF STREETS AND ALLEYS, AND A MINIMUM COEFFICIENT OF FRICTION OF 0.50 PER ASTM C 1028 FOR THOSE STEEL PLATE COVERS IN PEDESTRIAN CROSSWALKS OR ACCESSIBLE AREAS. THE NON-SKID COATING SHALL BE BLACK. WHEN REQUIRED BY THE ENGINEER, THE CONTRACTOR OR PERMITTEE SHALL CERIFY IN WRITING TO THE AGENCY THAT THE STEEL PLATE COVERS TO BE USED IN THE WORK MEET THE REQUIRED STATIC COEFFICIENT OF FRICTION. ALSO WHEN REQUIRED BY THE ENGINEER, THE CONTRACTOR SHALL HAVE THE STEEL PLATE COVERS TO BE USED IN THE WORK TESTED IN ACCORDANCE WITH THE ABOVE STANDARDS FOR THE VERIFICATION OF THE REQUIRED STATIC COEFFICIENT OF FRICTION. TESTING SHALL BE DONE BY AN INDEPENDENT LABORATORY APPROVED BY THE ENGINEER. THE CONTRACTOR OR PERMITTEE SHALL PAY FOR ANY COSTS ASSOCIATED WITH THE TESTING OF THE STEEL PLATE COVERS.

Revision	By	Apprvd	Date	CITY OF VISTA STANDARD DRAWING	
New	TR	SS	11/30/08		
Updated	TR	HH	05/07/12		
				DRAWING NUMBER: SRF-11B	

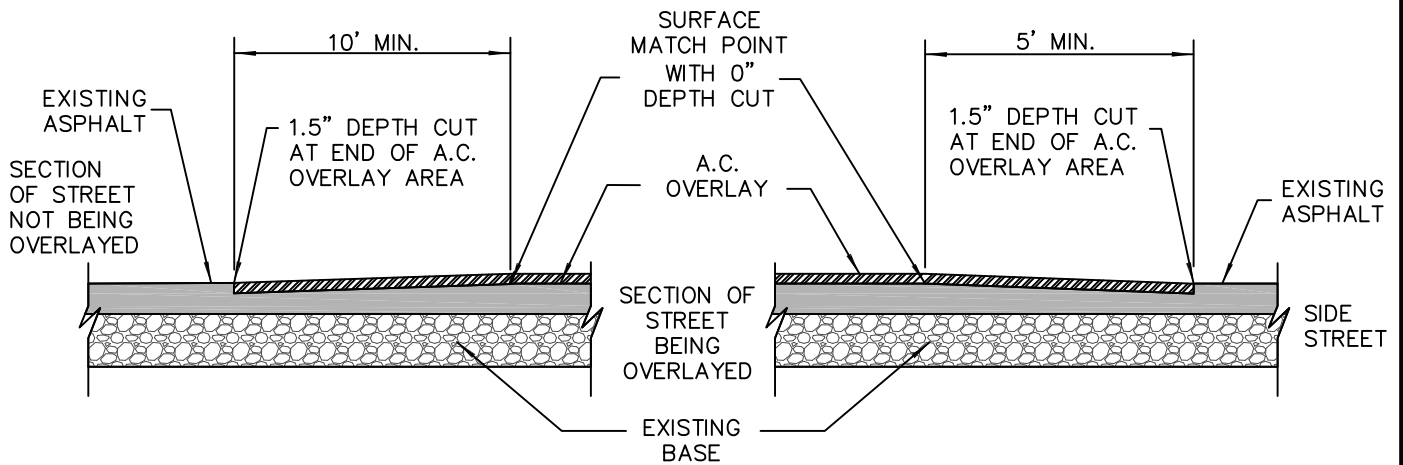

HEADER CUT ACROSS STREET

HEADER CUT AT SIDE STREET

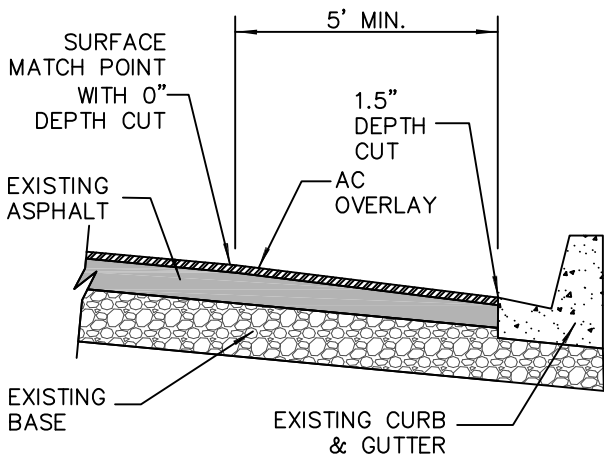

EDGE CUT NEXT TO EXISTING CURB & GUTTER

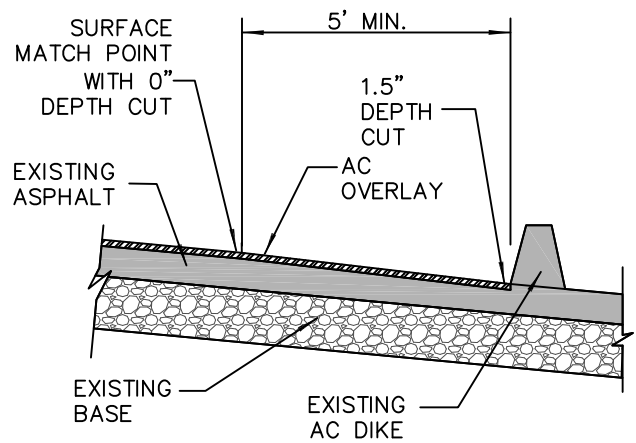

EDGE CUT NEXT TO EXISTING AC DIKE

Revision	By	Apprvd	Date
New	GL	SS	09/01/11

CITY OF VISTA
STANDARD DRAWING

COLD MILLING DETAILS

[Signature]
CITY ENGINEER, DATE
RCE 55075
DRAWING NUMBER: **SRF-12**

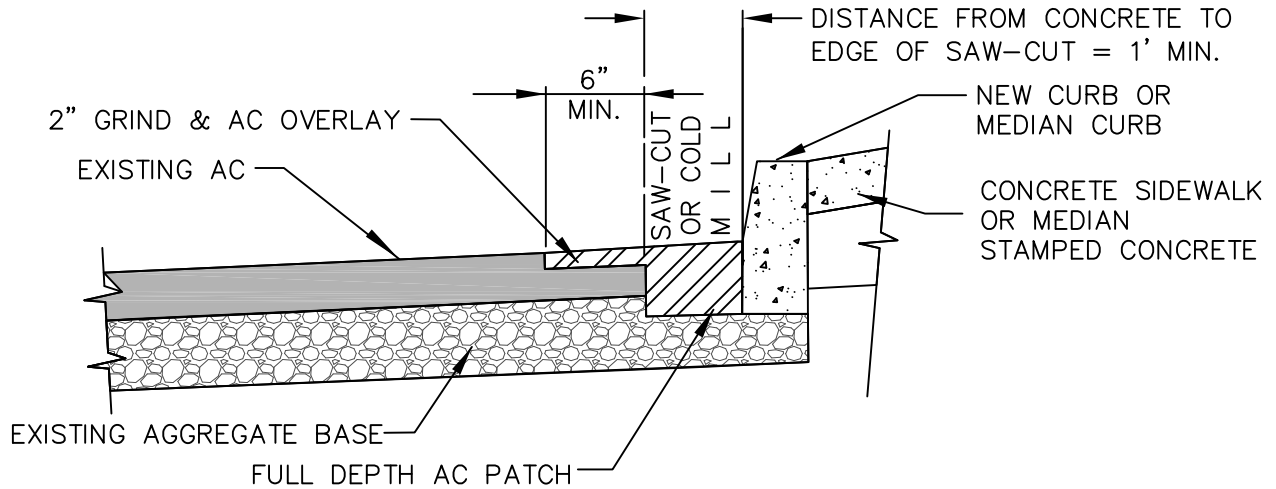
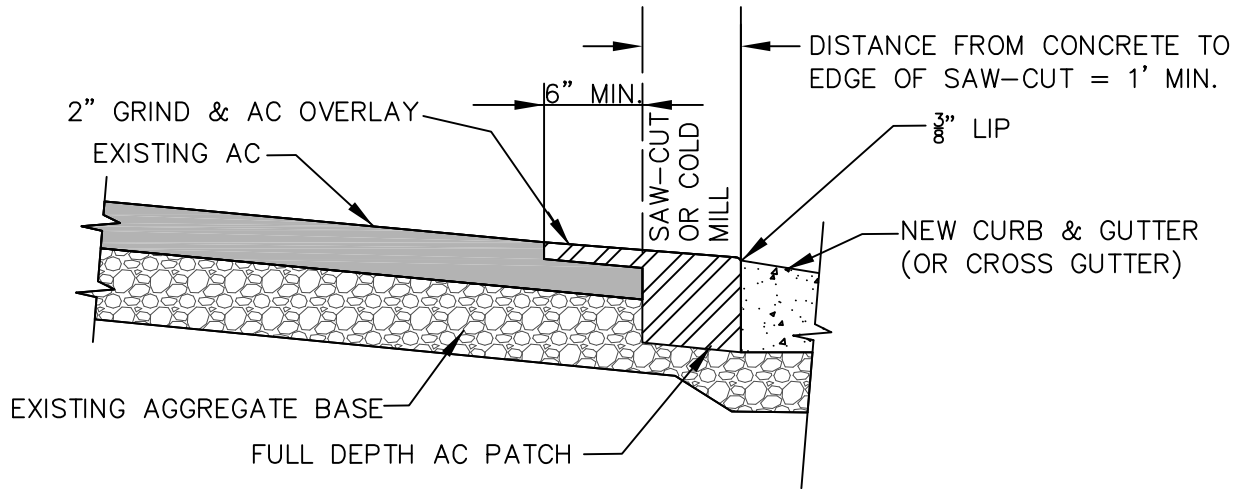

PAVEMENT RESTORATION FOR CURB & GUTTER OR CROSS GUTTER

Revision	By	Apprvd	Date
New	GL	TS	09/01/11

CITY OF VISTA
STANDARD DRAWING



**PAVEMENT RESTORATION
DETAILS**

CITY ENGINEER, DATE
RCE 55075

DRAWING NUMBER: **SRF-13**

RESURFACE STREET AFTER
 ABANDONING MONITORING WELL IN
 STREET PER CITY OF VISTA STD.
 DWG. SRF-08A & -08B, TYPE A

REPLACE SIDEWALK PER SDRSD
 G-11 AFTER ABANDONING
 MONITORING WELL IN SIDEWALK

EXISTING ASPHALT CONCRETE
 (THICKNESS VARIES)

EXISTING SIDEWALK
 (NOMINAL 4" THICKNESS)

SAND COMPACTION TO
 90% OR USE 1 SACK
 CONCRETE SLURRY

EXISTING AGGREGATE BASE
 (THICKNESS VARIES)

5' MIN.

MONITORING WELL SEALED WITH BENTONITE
 BACKFILL PER SAN DIEGO COUNTY DEPARTMENT
 OF ENVIRONMENTAL HEALTH REQUIREMENTS

SURFACE REPAIRS FOR MONITORING WELL ABANDONMENT

NOTE:

MONITORING WELLS SHALL, AT A MINIMUM, BE DESTROYED IN ACCORDANCE WITH THE REQUIREMENTS OF SECTION 23 OF THE WATER WELL STANDARDS IF LOCATED IN AN AREA FREE OF ANY KNOWN OR POTENTIAL CONTAMINATION OR POLLUTION.

Revision	By	Apprvd	Date	CITY OF VISTA STANDARD DRAWING	 CITY ENGINEER, DATE RCE 55075
New	TS	TS	03/01/12	MONITORING WELL ABANDONMENT	DATE
					DRAWING NUMBER: SRF-14

THIS SHEET
INTENTIONALLY LEFT BLANK

Revision	By	Apprvd	Date

CITY OF VISTA
STANDARD DRAWING



CITY ENGINEER, DATE
RCE 55075

DRAWING
NUMBER: **SRF-15**

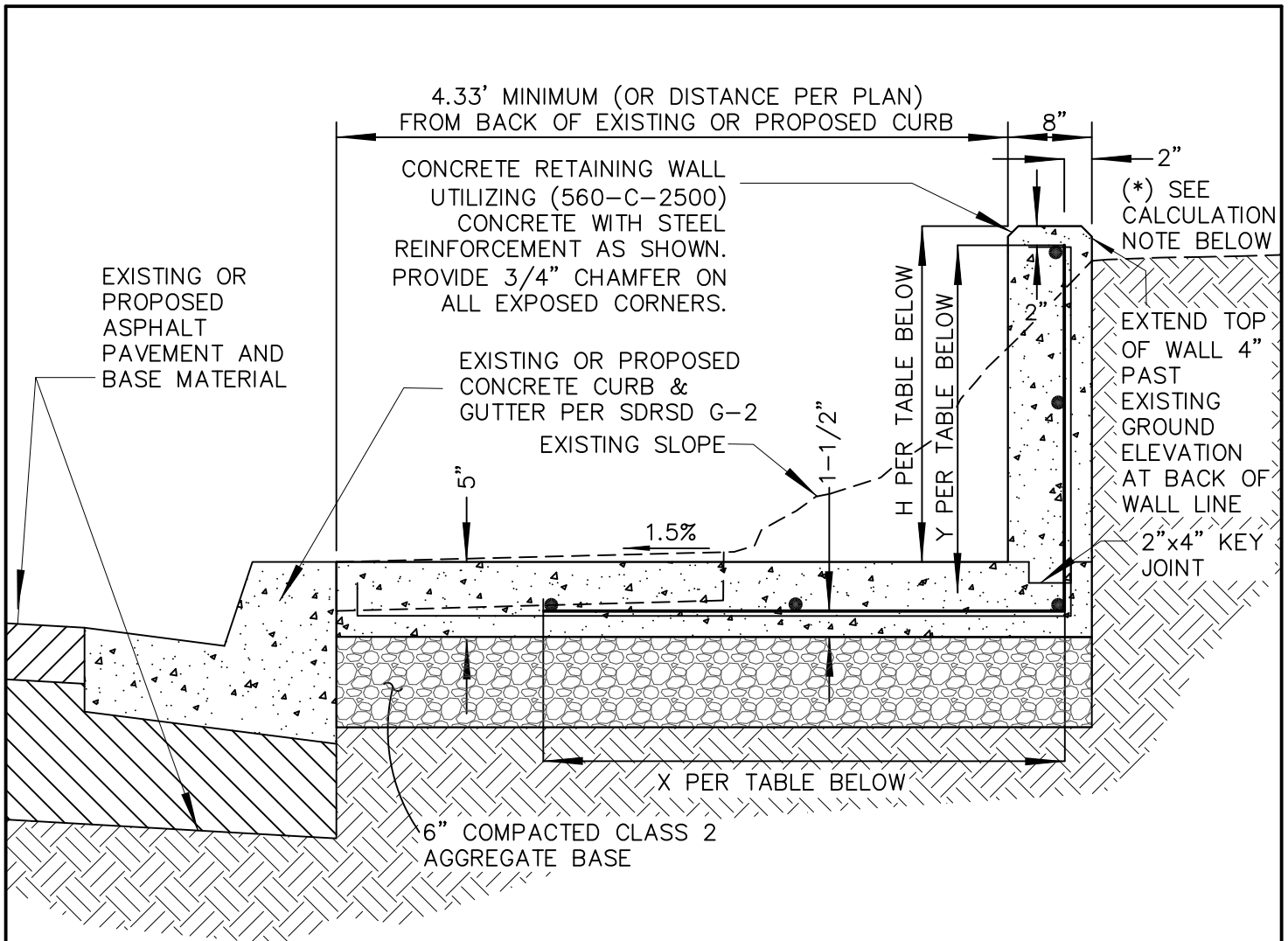

CONCRETE RETAINING WALL WITH ADJACENT SIDEWALK

H	X	Y	DIAGRAM
2'-0"	2'-6"	2'-1.5"	(4) #4 REBAR #4 REBAR @ 1' O.C.
3'-0"	2'-6"	3'-1.5"	(5) #4 REBAR #4 REBAR @ 1' O.C.

*** CALCULATION NOTE:**
 ENGINEER OF WORK TO PROVIDE STRUCTURAL CALCULATIONS FOR LOADING CONDITION BEHIND PROPOSED CONCRETE WALL

STEEL REINFORCEMENT PLACEMENT TABLE

Revision	By	Apprvd	Date	CITY OF VISTA STANDARD DRAWING	 CITY ENGINEER, DATE
New	GL	TS	12/01/11	CONCRETE RETAINING WALL AND SIDEWALK	RCE 55075
					DRAWING NUMBER: SRF-16

**THIS SHEET INTENTIONALLY
LEFT BLANK**

TRAFFIC AND STRIPING

**THIS SHEET INTENTIONALLY
LEFT BLANK**

THIS SHEET
INTENTIONALLY LEFT BLANK

Revision	By	Apprvd	Date	CITY OF VISTA STANDARD DRAWING	
New		GR	05/23/85		
Updated	TR	GM	03/26/13	STOP SIGN, STOP BAR AND CROSSWALK LOCATION DETAILS	CITY ENGINEER, DATE RCE 55075
Updated	GL	HH	05/07/14		
				DRAWING NUMBER:	TRF-01

W17-1
(BUMP)

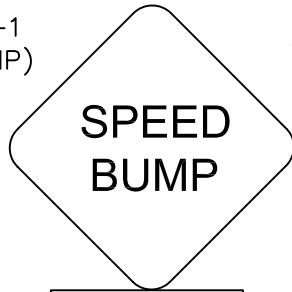

SIGN DETAILS

W17-1
(BUMP)

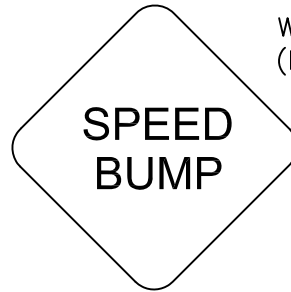

W16-9P

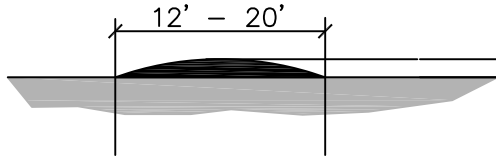

2-5/8" - 3-1/8" (PER COUNCIL POLICY 600-07).

SPEED BUMP SECTION

PAINT PER CALIFORNIA MUTCD FIGURE 3B-29 OPTION A (SEE NOTE 3)

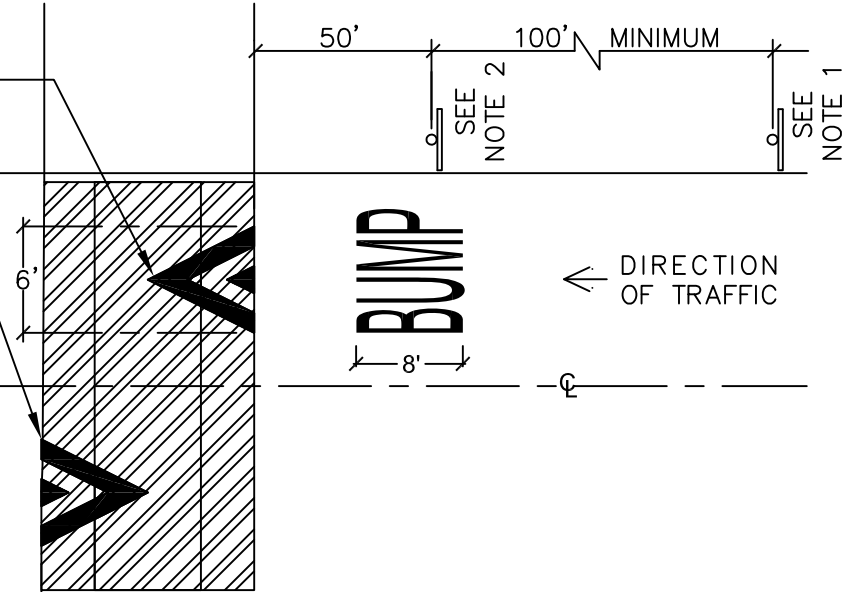

DIRECTION OF TRAFFIC →

← DIRECTION OF TRAFFIC



PLAN

USE ON PRIVATE PROPERTY:
PRIVATE PROPERTY OWNERS AND MANAGERS MAY CHOOSE TO USE THIS STANDARD FOR INSTALLING SPEED BUMPS ON THEIR PROPERTY OR STREET. HOWEVER, PROPERTY OWNERS AND MANAGERS ARE WHOLLY RESPONSIBLE FOR THE USE OF THIS STANDARD OR ANY CONSEQUENCES.

NOTES:

1. A SINGLE SPEED BUMP AHEAD (W-17-1/W16-9P) SIGN SHALL BE INSTALLED IN ADVANCE OF THE FIRST BUMP IN EACH DIRECTION.
2. SPEED BUMP (W17-1) SIGN MAY BE INSTALLED IN ADVANCE OF EACH INDIVIDUAL SPEED BUMP.
3. PAINT 12" SOLID WHITE LEGEND AS SHOWN AND PER CALIFORNIA MUTCD FIGURE 3B-29 OPTION A.

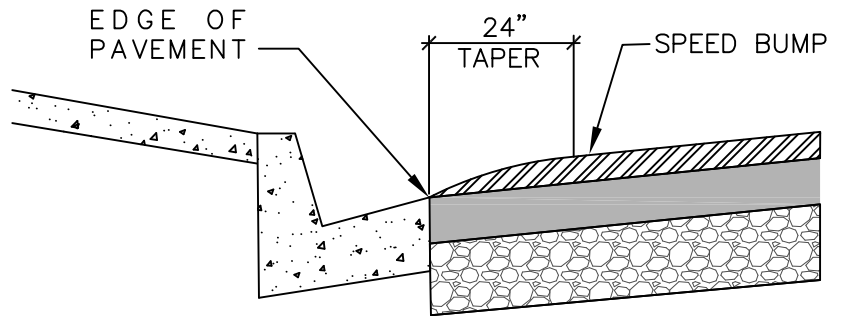

EDGE DETAIL

Revision	By	Apprvd	Date
New	TR	HH	12/18/12
Updated	GL	HH	05/07/14

CITY OF VISTA
STANDARD DRAWING

SPEED BUMPS

CITY ENGINEER, DATE
RCE 55075
DRAWING NUMBER: **TRF-02**

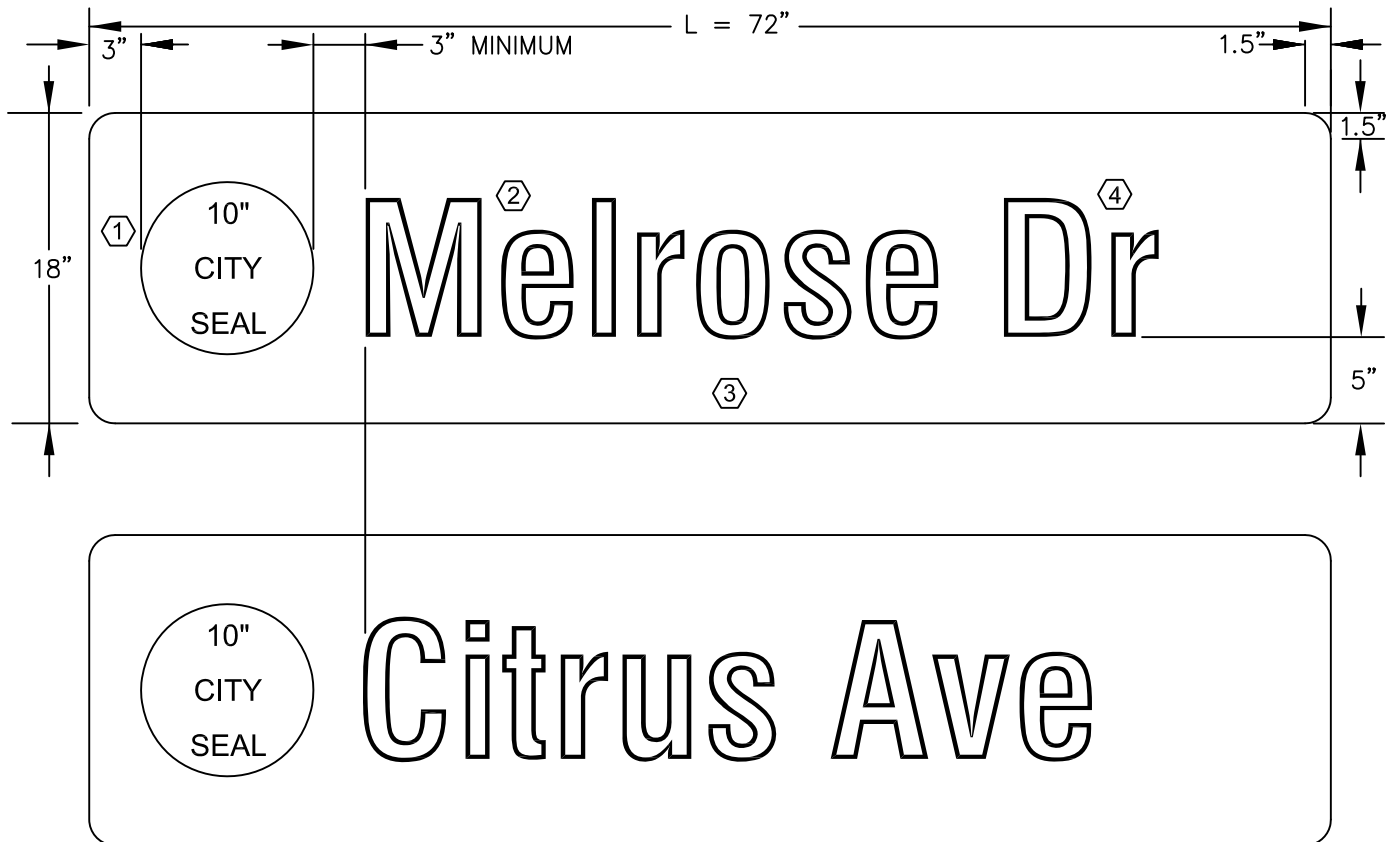

TYPICAL PUBLIC STREET NAME SIGN LAYOUT AT SIGNALIZED INTERSECTIONS

- ① REFLECTIVE 10" CITY SEAL ON THE LEFT SIDE OF ALL PUBLIC STREET NAME SIGNS AT SIGNALIZED INTERSECTIONS. REQUEST THE DIGITAL FILE OF THE CITY SEAL FROM THE ENGINEERING DEPARTMENT.
- ② DIAMOND GRADE WHITE 8" D-SERIES FHWA FONT FOR UPPERCASE LETTERING AND 6" D-SERIES FHWA FONT FOR LOWERCASE LETTERING WITH 3M HIGHWAY BLUE (OR APPROVED EQUAL) BACKGROUND.
- ③ 0.080 GAUGE ALUMINUM WITH FRAMED BACKING, SINGLE FACE WITH DIAMOND GRADE 3 REVERSE SCREENED REFLECTIVE SHEETING.
- ④ PREFERRED ABBREVIATIONS:

AVENUE: AV OR AVE	DRIVE: DR	PARK: PK	STREET: ST
BOULEVARD: BL OR BLVD	HEIGHTS: HTS	PARKWAY: PKY OR PKWY	TERRACE: TER
CANYON: CYN	HIGHWAY: HWY	PLACE: PL	TRAIL: TR
CIRCLE: CIR	LANE: LN	ROAD: RD	WAY: WY OR WAY

Revision	By	Apprvd	Date	CITY OF VISTA STANDARD DRAWING	
New	TR	LP	11/14/08	STREET NAME SIGN DETAILS FOR SIGNALIZED INTERSECTIONS	CITY ENGINEER, DATE RCE 55075
Updated	TR	SS	12/16/10		
Updated	GL	HH	05/07/14		
					DRAWING NUMBER: TRF-03A



TYPICAL PUBLIC STREET NAME SIGN LAYOUT AT SIGNALIZED INTERSECTIONS

- ① REFLECTIVE 10" CITY SEAL ON THE LEFT SIDE OF ALL PUBLIC STREET NAME SIGNS AT SIGNALIZED INTERSECTIONS. REQUEST THE DIGITAL FILE OF THE CITY SEAL FROM THE ENGINEERING DEPARTMENT.
- ② DIAMOND GRADE WHITE 8" D-SERIES FHWA FONT FOR UPPERCASE LETTERING AND 6" D-SERIES FHWA FONT FOR LOWERCASE LETTERING WITH 3M HIGHWAY BLUE (OR APPROVED EQUAL) BACKGROUND.
- ③ 0.080 GAUGE ALUMINUM WITH FRAMED BACKING, SINGLE FACE WITH DIAMOND GRADE 3 REVERSE SCREENED REFLECTIVE SHEETING.
- ④ PREFERRED ABBREVIATIONS:

AVENUE: AV OR AVE	DRIVE: DR	PARK: PK	STREET: ST
BOULEVARD: BL OR BLVD	HEIGHTS: HTS	PARKWAY: PKY OR PKWY	TERRACE: TER
CANYON: CYN	HIGHWAY: HWY	PLACE: PL	TRAIL: TR
CIRCLE: CIR	LANE: LN	ROAD: RD	WAY: WY OR WAY

Revision	By	Apprvd	Date	CITY OF VISTA STANDARD DRAWING	
New	TR	LP	11/14/08		
Updated	TR	SS	12/16/10	STREET NAME SIGN DETAILS FOR SIGNALIZED INTERSECTIONS	CITY ENGINEER, DATE RCE 55075
Updated	GL	HH	05/07/14		DRAWING NUMBER: TRF-03B

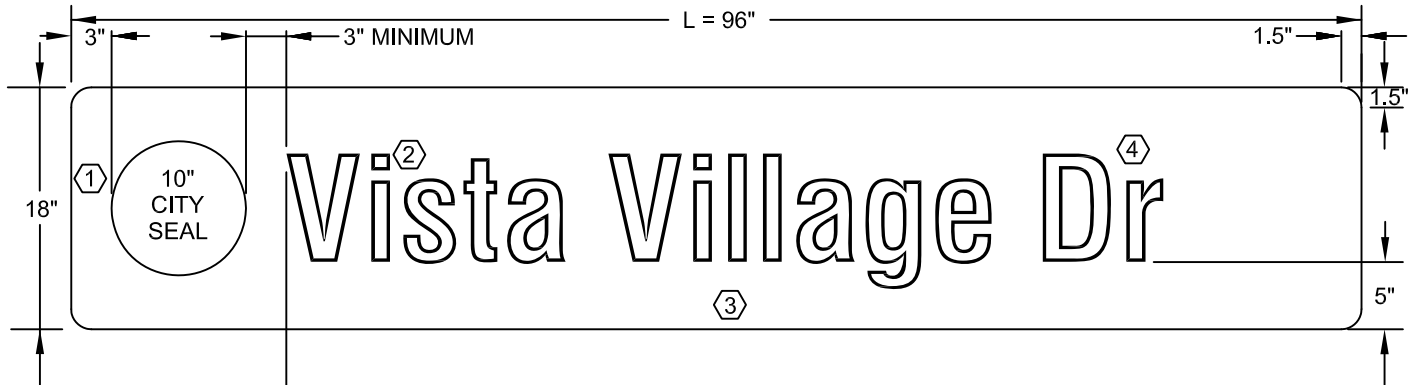

TYPICAL PUBLIC STREET NAME SIGN LAYOUT AT SIGNALIZED INTERSECTIONS

- ① REFLECTIVE 10" CITY SEAL ON THE LEFT SIDE OF ALL PUBLIC STREET NAME SIGNS AT SIGNALIZED INTERSECTIONS. REQUEST THE DIGITAL FILE OF THE CITY SEAL FROM THE ENGINEERING DEPARTMENT.
- ② DIAMOND GRADE WHITE 8" D-SERIES FHWA FONT FOR UPPERCASE LETTERING AND 6" D-SERIES FHWA FONT FOR LOWERCASE LETTERING WITH 3M HIGHWAY BLUE (OR APPROVED EQUAL) BACKGROUND.
- ③ 0.080 GAUGE ALUMINUM WITH FRAMED BACKING, SINGLE FACE WITH DIAMOND GRADE 3 REVERSE SCREENED REFLECTIVE SHEETING.

④ PREFERRED ABBREVIATIONS:

AVENUE: AV OR AVE	DRIVE: DR	PARK: PK	STREET: ST
BOULEVARD: BL OR BLVD	HEIGHTS: HTS	PARKWAY: PKY OR PKWY	TERRACE: TER
CANYON: CYN	HIGHWAY: HWY	PLACE: PL	TRAIL: TR
CIRCLE: CIR	LANE: LN	ROAD: RD	WAY: WY OR WAY

Revision	By	Apprvd	Date	CITY OF VISTA STANDARD DRAWING	
New	TR	LP	11/14/08	STREET NAME SIGN DETAILS FOR SIGNALIZED INTERSECTIONS	CITY ENGINEER, DATE RCE 55075
Updated	TR	SS	12/16/10		
Updated	GL	HH	05/07/14		DRAWING NUMBER: TRF-03C

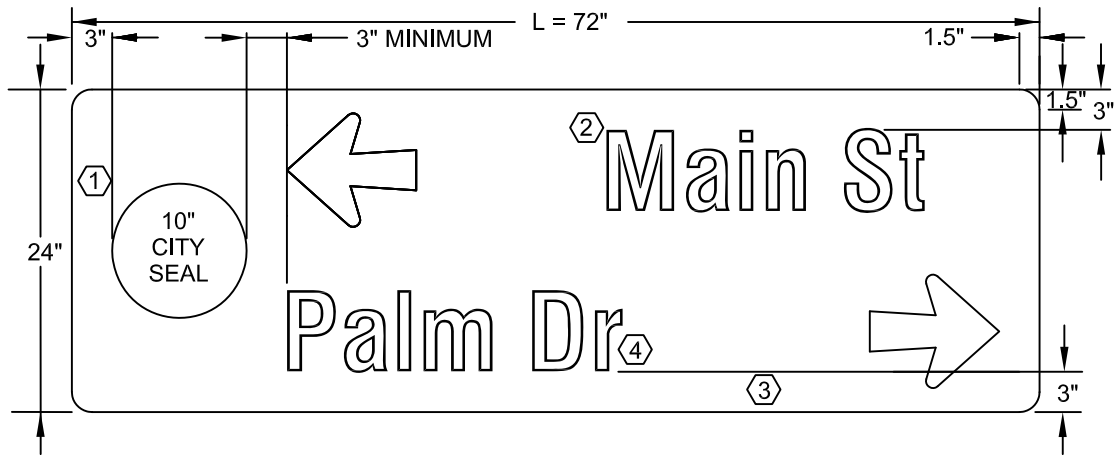

CENTER LEGENDS

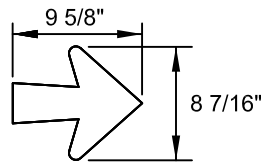

TYPICAL PUBLIC STREET NAME SIGN LAYOUT AT SIGNALIZED INTERSECTIONS

- ① REFLECTIVE 10" CITY SEAL ON THE LEFT SIDE OF ALL PUBLIC STREET NAME SIGNS AT SIGNALIZED INTERSECTIONS. REQUEST THE DIGITAL FILE OF THE CITY SEAL FROM THE ENGINEERING DEPARTMENT.
- ② DIAMOND GRADE WHITE 8" D-SERIES FHWA FONT FOR UPPERCASE LETTERING AND 6" D-SERIES FHWA FONT FOR LOWERCASE LETTERING WITH 3M HIGHWAY BLUE (OR APPROVED EQUAL) BACKGROUND.
- ③ 0.080 GAUGE ALUMINUM WITH FRAMED BACKING, SINGLE FACE WITH DIAMOND GRADE 3 REVERSE SCREENED REFLECTIVE SHEETING.
- ④ PREFERRED ABBREVIATIONS:

AVENUE: AV OR AVE	DRIVE: DR	PARK: PK	STREET: ST
BOULEVARD: BL OR BLVD	HEIGHTS: HTS	PARKWAY: PKY OR PKWY	TERRACE: TER
CANYON: CYN	HIGHWAY: HWY	PLACE: PL	TRAIL: TR
CIRCLE: CIR	LANE: LN	ROAD: RD	WAY: WY OR WAY

Revision	By	Apprvd	Date	CITY OF VISTA STANDARD DRAWING	
New	TR	LP	11/14/08	STREET NAME SIGN DETAILS FOR SIGNALIZED INTERSECTIONS	CITY ENGINEER, DATE RCE 55075
Updated	TR	SS	12/16/10		
Updated	GL	HH	05/07/14		DRAWING NUMBER: TRF-03D

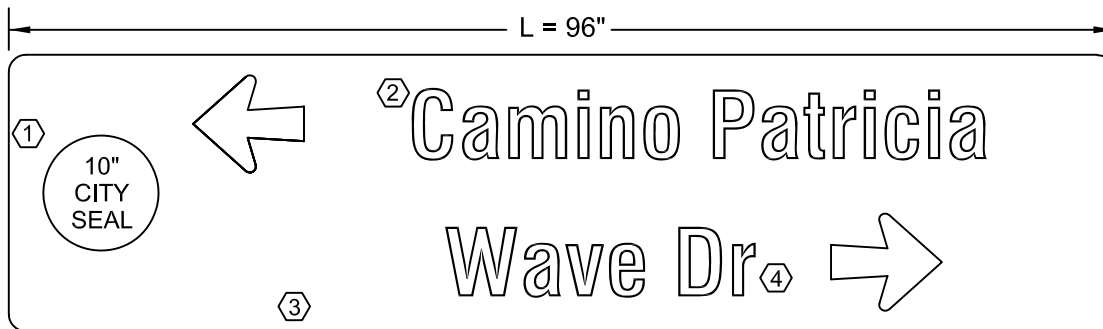
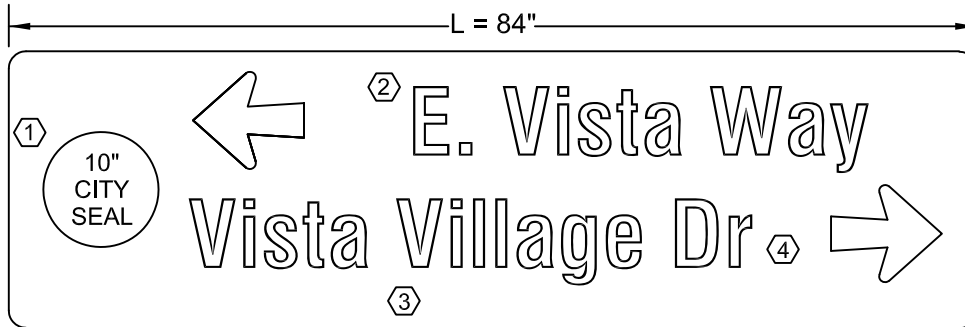
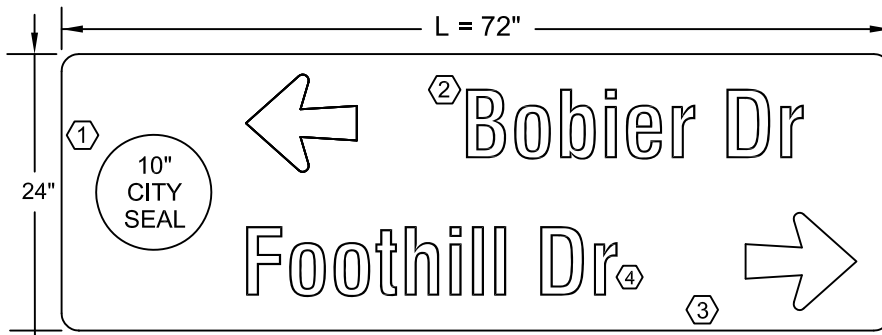

TYPICAL PUBLIC STREET NAME SIGN LAYOUT AT SIGNALIZED INTERSECTIONS

- ① REFLECTIVE 10" CITY SEAL ON THE LEFT SIDE OF ALL PUBLIC STREET NAME SIGNS AT SIGNALIZED INTERSECTIONS. REQUEST THE DIGITAL FILE OF THE CITY SEAL FROM THE ENGINEERING DEPARTMENT.
- ② DIAMOND GRADE WHITE 8" D-SERIES FHWA FONT FOR UPPERCASE LETTERING AND 6" D-SERIES FHWA FONT FOR LOWERCASE LETTERING WITH 3M HIGHWAY BLUE (OR APPROVED EQUAL) BACKGROUND.
- ③ 0.080 GAUGE ALUMINUM WITH FRAMED BACKING, SINGLE FACE WITH DIAMOND GRADE 3 REVERSE SCREENED REFLECTIVE SHEETING.
- ④ PREFERRED ABBREVIATIONS:

AVENUE: AV OR AVE	DRIVE: DR	PARK: PK	STREET: ST
BOULEVARD: BL OR BLVD	HEIGHTS: HTS	PARKWAY: PKY OR PKWY	TERRACE: TER
CANYON: CYN	HIGHWAY: HWY	PLACE: PL	TRAIL: TR
CIRCLE: CIR	LANE: LN	ROAD: RD	WAY: WY OR WAY

Revision	By	Apprvd	Date	CITY OF VISTA STANDARD DRAWING	
New	TR	LP	11/14/08	STREET NAME SIGN DETAILS FOR SIGNALIZED INTERSECTIONS	
Updated	TR	SS	12/16/10		CITY ENGINEER, DATE RCE 55075
Updated	GL	HH	05/07/14		DRAWING NUMBER: TRF-03E

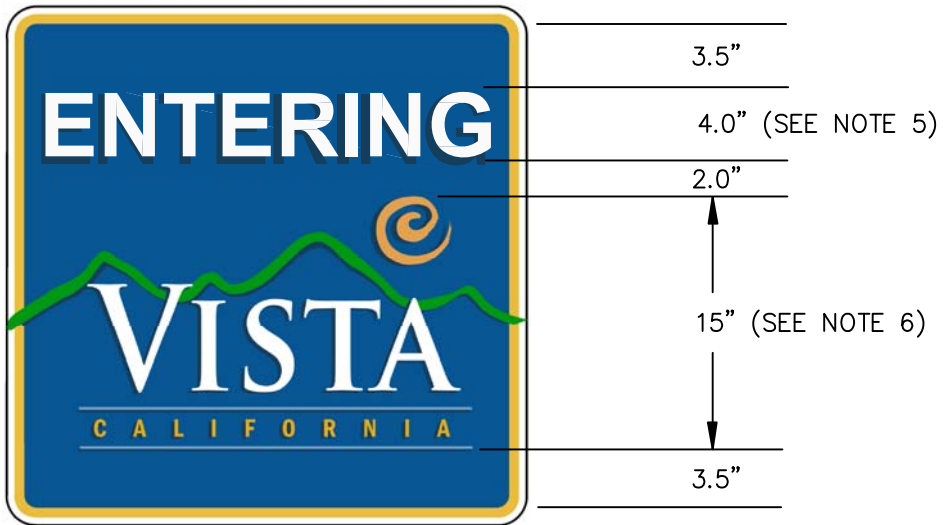

30" x 30"

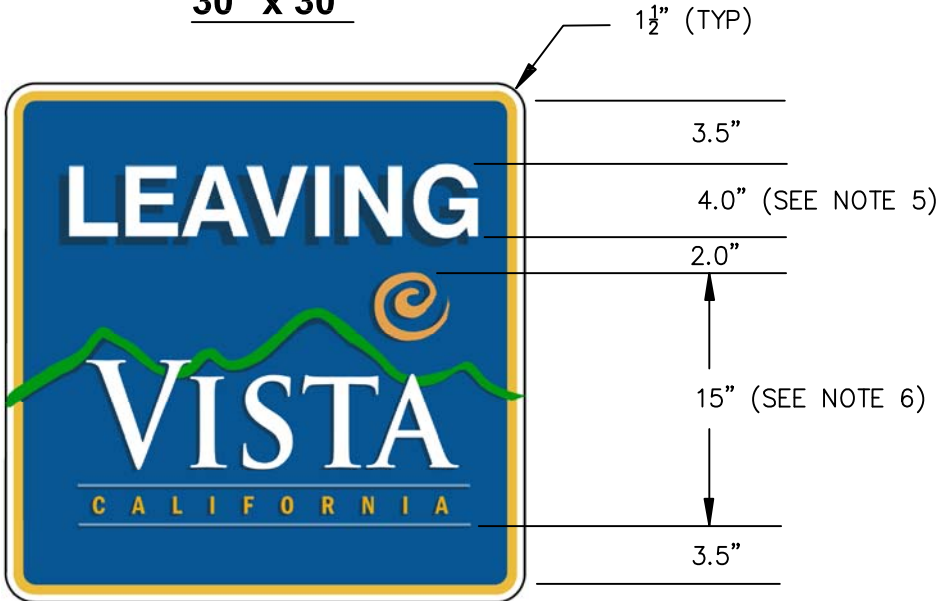

30" x 30"

NOTES:

1. BORDER WIDTH = 5/8"; COLOR: WHITE.
2. MARGIN WIDTH = 3/8"; COLOR: GOLD – PANTONE #143C (C-8 M-33 Y-82 K-1).
3. BACKGROUND COLOR: DARK BLUE – PANTONE #295C (C-100 M-57 Y-0 K-40).
4. USE 0.080 GAUGE ALUMINUM WITH HIGH INTENSITY PRISMATIC RETRO-REFLECTIVE SHEETING.
5. USE 4" D-SERIES FHWA WHITE FONT.
6. REQUEST THE STANDARD CITY LOGO DIGITAL FILE FROM THE ENGINEERING DEPARTMENT.

Revision	By	Apprvd	Date	CITY OF VISTA STANDARD DRAWING	 CITY ENGINEER, DATE RCE 55075
New	RC	SS	04/05/10		
Updated	TR	GM	12/18/12	ENTERING & LEAVING CITY SIGN DETAILS	DRAWING NUMBER: TRF-04

TYPICAL LOOP DETECTOR LAYOUT

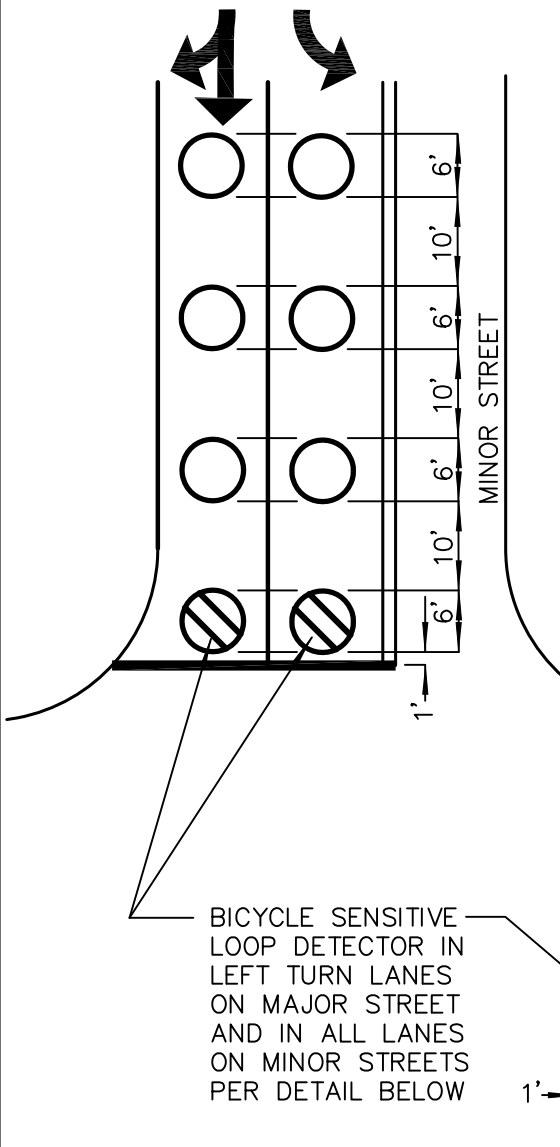

NOTES

1. ALL LOOP DETECTORS SHALL BE INSTALLED IN PAVEMENT SURFACE.
2. ALL LOOP DETECTORS SHALL BE CENTERED IN LANE, UNLESS OTHERWISE NOTED.
3. ADVANCE LOOPS SHALL BE INSTALLED FOR MAJOR STREET THROUGH MOVEMENTS PER STANDARDS ESTABLISHED IN THE LATEST EDITION OF THE CALIFORNIA MANUAL ON UNIFORM TRAFFIC CONTROL DEVICES (CA - MUTCD).
4. FIRST LOOP IN EVERY TRAVEL LANE, EXCEPT FOR STRAIGHT THROUGH LANES ON THE MAJOR STREET APPROACHES, SHALL BE A BICYCLE SENSITIVE LOOP.

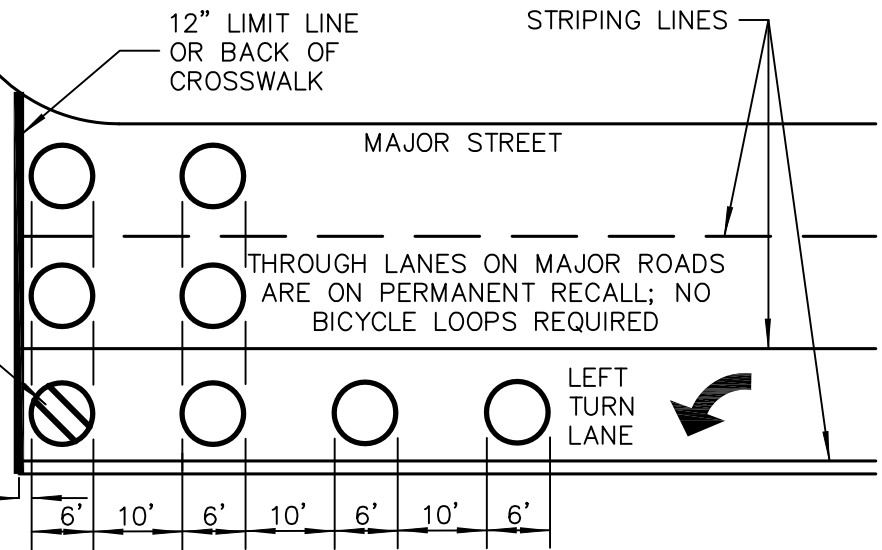

MODIFIED TYPE E BICYCLE SENSITIVE LOOP SAWCUT AND WINDING DETAIL

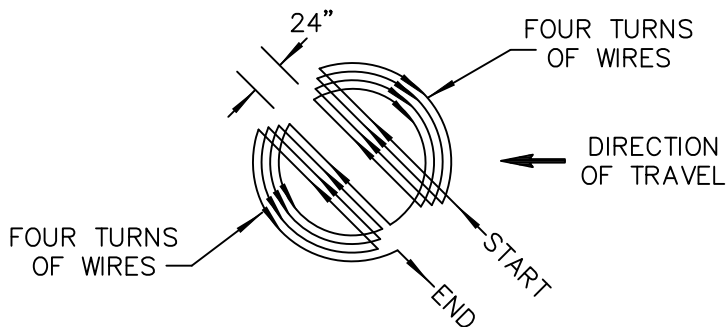

NOTES:

1. LOOP DIAMETER IS 6' (TYP.)
2. DEPTH OF CUT IS 3 1/8" MIN.
3. ROUND CORNERS TO REDUCE WEAR OF LOOP WIRE.



Revision	By	Apprvd	Date
New	RC	LP	04/05/10
Updated	GL	SS	02/08/11
Updated	CP	HH	01/08/14
Updated	GL	HH	05/07/14

CITY OF VISTA
STANDARD DRAWING

[Signature]

**STANDARD LOOP
DETECTOR LAYOUT**

CITY ENGINEER, DATE
RCE 55075

DRAWING NUMBER: **TRF-05**

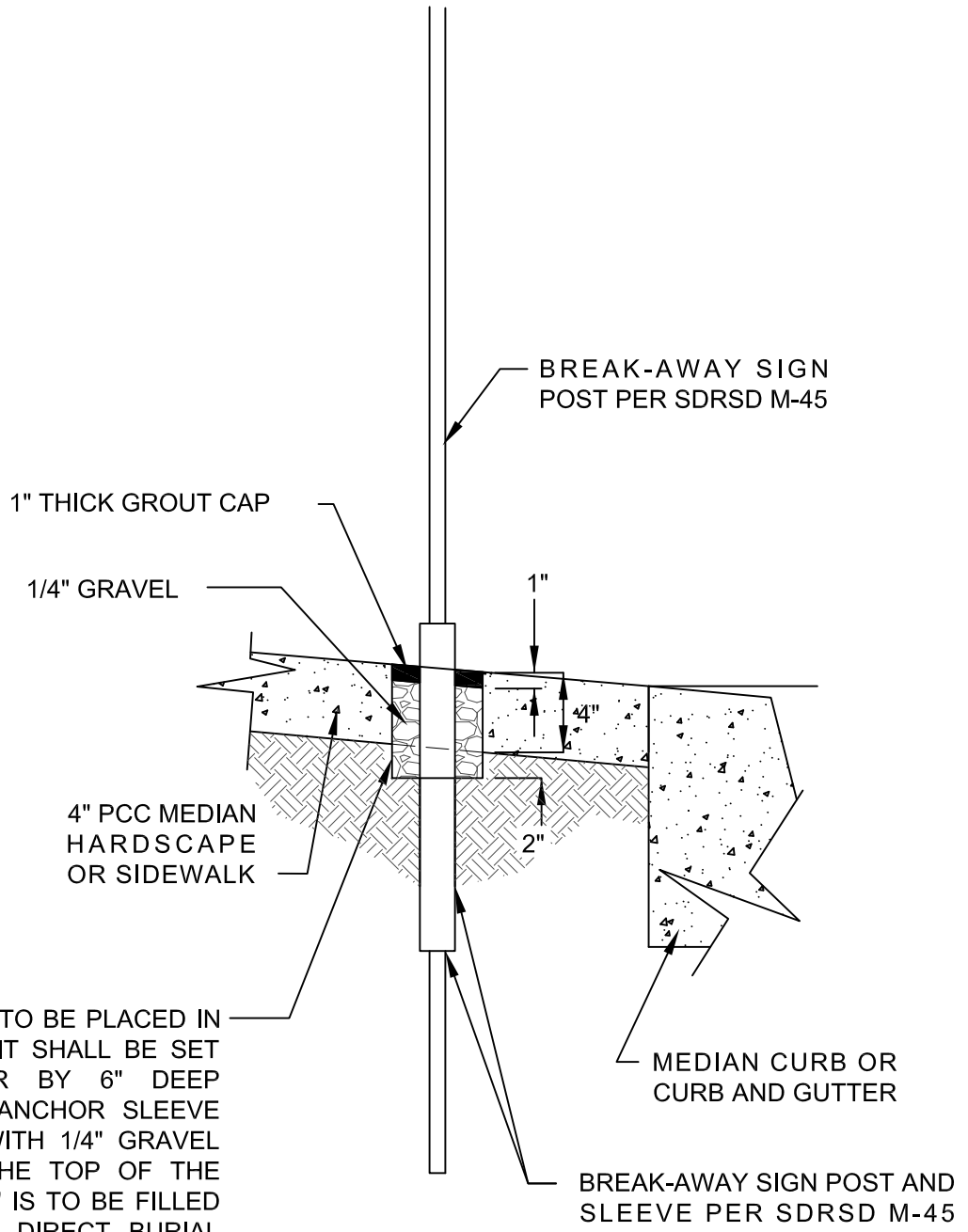

WHEN SIGN POST IS TO BE PLACED IN HARDSCAPE AREAS IT SHALL BE SET IN A 4" DIAMETER BY 6" DEEP SCHEDULE 40 PVC ANCHOR SLEEVE AND BACK FILLED WITH 1/4" GRAVEL TO WITHIN 1" OF THE TOP OF THE SLEEVE; THE LAST 1" IS TO BE FILLED WITH GROUT. USE DIRECT BURIAL WHERE SIGN IS TO BE PLACED IN SOIL.

BREAK-AWAY SIGN POST

Revision	By	Apprvd	Date
New	GL	SS	04/26/11
Updated	GL	HH	12/18/12

CITY OF VISTA
STANDARD DRAWING

SIGN POST
FOOTING IN HARDSCAPE

[Signature]
CITY ENGINEER, DATE
RCE 55075

DRAWING NUMBER: **TRF-06**